

**Screw  
Jacks**

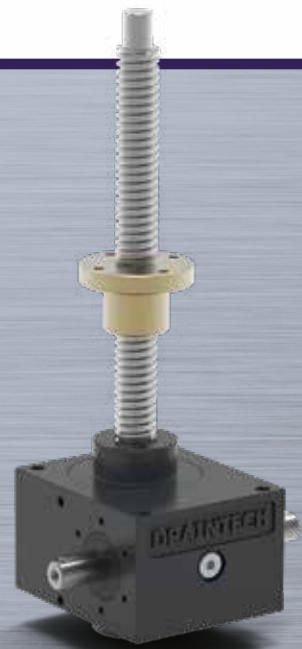

**DHT SERIES  
HS SERIES**



**Ball screw jacks**



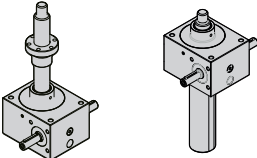

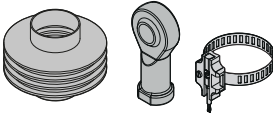
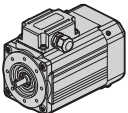
	Indice	Index	Pag. Page	
	<b>A</b>	Introduzione	<i>Introduction</i>	A1
	<b>B</b>	Martinetti a vite trapezia DHT	<i>Trapezoidal screw jacks</i> DHT	B1
	<b>C</b>	Martinetti per aste a ricircolo di sfere HS	<i>Ball screw jacks</i> HS	C1
	<b>D</b>	Accessori	<i>Accessories</i>	D1
	<b>E</b>	Motori applicabili	<i>Applicable motors</i>	E1

Questo catalogo annulla e sostituisce ogni precedente edizione o revisione.  
Ci riserviamo inoltre il diritto di apportare modifiche senza preavviso.  
La versione più aggiornata è disponibile sul sito  
[www.transtecno.com](http://www.transtecno.com)

*This catalogue supersedes any previous edition and revision.  
We reserve the right to implement modifications without notice.  
The most updated version is available on our website  
[www.transtecno.com](http://www.transtecno.com)*



<b>Indice</b>	<b>Index</b>	<b>Pag. Page</b>
Generalità	<i>Generality</i>	<b>A2</b>
Simbologia	<i>Symbols</i>	<b>A2</b>
Definizione dei carichi	<i>Definition of loads</i>	<b>A3</b>
Carico unitario	<i>Unit load</i>	<b>A3</b>
Carico equivalente - DHT	<i>Equivalent load - DHT</i>	<b>A3</b>
Carico equivalente - HS	<i>Equivalent load - HS</i>	<b>A3</b>
Carichi radiali	<i>Radial loads</i>	<b>A4</b>
Momento torcente	<i>Torque</i>	<b>A4</b>
Carico laterale	<i>Side load</i>	<b>A5</b>
Verifica a carico di punta	<i>Peak load test</i>	<b>A6</b>
Gioco d'ingranamento tra vite senza fine e corona elicoidale	<i>Coupling backlash between worm screw and helical crown</i>	<b>A8</b>
Gioco laterale nei modelli "T"	<i>Side backlash in 'T' models</i>	<b>A8</b>
Gioco laterale nei modelli "R"	<i>Side backlash in 'R' models</i>	<b>A8</b>
Gioco assiale	<i>Axial backlash</i>	<b>A8</b>
Lubrificazione	<i>Lubrication</i>	<b>A9</b>
Dimensionamento del martinetto	<i>Screw jack sizing</i>	<b>A11</b>
DHT	<i>DHT</i>	<b>A12</b>
HS	<i>HS</i>	<b>A15</b>
Formule di calcolo	<i>Calculation formulas</i>	<b>A19</b>

Questa sezione annulla e sostituisce ogni precedente edizione o revisione. Qualora questa sezione non Vi sia giunta in distribuzione controllata, l'aggiornamento dei dati ivi contenuto non è assicurato. **In tal caso la versione più aggiornata è disponibile sul nostro sito internet [www.transtecno.com](http://www.transtecno.com)**

*This section replaces any previous edition and revision. If you obtained this catalogue other than through controlled distribution channels, the most up to date content is not guaranteed. In this case the latest version is available on our web site [www.transtecno.com](http://www.transtecno.com)*

## Generalità

## Generality

Il martinetto meccanico permette di trasformare il movimento rotatorio fornito da un motore elettrico in un movimento lineare che consente di effettuare sollevamenti verticali in tiro, in spinta o posizionamenti orizzontali.

*The mechanical screw jack makes it possible to transform the rotary movement provided by an electric motor into a linear movement that enables vertical lifting in pull, pushing or horizontal positioning.*

## Simbologia

## Symbols used

A = velocità angolare massima della vite senza fine [rpm]	<i>A = maximum angular speed of the worm gear [rpm]</i>
B = frequenza del ciclo di carico [Hz]	<i>B = load cycle frequency [Hz]</i>
$P_e$ = potenza equivalente [kW]	<i><math>P_e</math> = equivalent power [kW]</i>
$P_{ei}$ = potenza equivalente in ingresso al singolo martinetto [kW]	<i><math>P_{ei}</math> = equivalent input power of the single screw jack [kW]</i>
$P_{max}$ = potenza massima in ingresso al martinetto [kW]	<i><math>P_{max}</math> = maximum screw jack input power [kW]</i>
P = potenza necessaria [kW]	<i>P = required power [kW]</i>
C = carico unitario [daN]	<i>C = unit load [daN]</i>
v = velocità di traslazione [mm/min]	<i>v = travel speed [mm/min]</i>
$\eta_m$ = rendimento del martinetto [%]	<i><math>\eta_m</math> = screw jack efficiency [%]</i>
$\eta_c$ = rendimento della configurazione = $1 - [(N-1) \cdot 0.05]$ [%]	<i><math>\eta_c</math> = configuration efficiency = <math>1 - [(N-1) \cdot 0.05]</math> [%]</i>
N = numero totale di martinetti e rinvii	<i>N = total number of screw jacks and gearboxes</i>
n = numero di martinetti	<i>n = number of screw jacks</i>
p = passo della vite [mm]	<i>p = screw pitch [mm]</i>
i = rapporto di riduzione	<i>i = reduction ratio</i>
$\eta_s$ = rendimento della struttura [%] (guide, cinghie, pulegge, alberi, giunti, riduttori)	<i><math>\eta_s</math> = efficiency of the structure [%] (guides, belts, pulleys, shafts, couplings, gearboxes)</i>
$M_{tm}$ = momento torcente sull'albero motore [daNm]	<i><math>M_{tm}</math> = torque on the motor shaft [daNm]</i>
$M_1$ = momento torcente in ingresso al martinetto [Nm]	<i><math>M_1</math> = screw jack input torque [Nm]</i>
$M_2$ = momento torcente in uscita al martinetto [Nm]	<i><math>M_2</math> = screw jack output torque [Nm]</i>
$M_{tvm\max}$ = momento torcente massimo sulla vite [daNm]	<i><math>M_{tvm\max}</math> = maximum torque on the screw [daNm]</i>
$n_1$ = velocità angolare del motore [rpm]	<i><math>n_1</math> = angular motor speed [rpm]</i>
$f_t$ = fattore di temperatura	<i><math>f_t</math> = temperature factor</i>
$f_a$ = fattore ambientale	<i><math>f_a</math> = environmental factor</i>
$f_s$ = fattore di servizio	<i><math>f_s</math> = service factor</i>
$F_{rv}$ = carico radiale [daN]	<i><math>F_{rv}</math> = radial load [daN]</i>
$C_e$ = carico equivalente [daN]	<i><math>C_e</math> = equivalent load [daN]</i>
$f_g$ = fattore di utilizzo	<i><math>f_g</math> = utilisation factor</i>
$f_d$ = fattore di durata	<i><math>f_d</math> = duration factor</i>
$P_j$ = potenza d'inerzia [kW]	<i><math>P_j</math> = inertia power [kW]</i>
$\eta_a$ = rendimento vite a ricircolo di sfere [%]	<i><math>\eta_a</math> = ball screw efficiency [%]</i>
$J_m$ = inerzia martinetto [kgmm <sup>2</sup> ]	<i><math>J_m</math> = screw jack inertia [kgmm<sup>2</sup>]</i>
J = inerzia totale [kgmm <sup>2</sup> ]	<i>J = total inertia [kgmm<sup>2</sup>]</i>

### CARICO UNITARIO

In funzione del numero di martinetti presenti nello schema di impianto si può calcolare il carico per martinetto dividendo il carico totale per n. numero di martinetti che concorrono ad azionare il sistema.

Qualora il carico non fosse equamente ripartito tra tutti i martinetti, è necessario considerare la trasmissione più sollecitata. In funzione di questo valore, leggendo le tabelle descrittive, si può fare una prima selezione scegliendo tra le taglie che presentano un valore di portata ammissibile superiore al carico unitario.

### CARICO EQUIVALENTE - serie DHT

Tutti i valori della serie DHT riportati dal catalogo sono riferiti ad un utilizzo in condizioni standard, cioè con temperatura pari a 20 °C e percentuale di funzionamento del 10%.

Per condizioni applicative differenti è necessario calcolare il carico equivalente: esso è il carico che bisognerebbe applicare in condizioni standard per avere gli stessi effetti di scambio termico e usura che il carico reale sortisce nelle reali condizioni di utilizzo.

Pertanto è opportuno calcolare il carico equivalente come da formula seguente:

$$C_e = C \cdot f_t \cdot f_a \cdot f_s$$

### CARICO EQUIVALENTE - serie HS

Tutti i valori riportati dal catalogo sono riferiti ad un utilizzo in condizioni standard, cioè con temperatura pari a 20 °C e funzionamento regolare e senza urti per 8 ore di funzionamento al giorno.

L'utilizzo in queste condizioni prevede una durata di 10'000 ore con una percentuale di servizio del 70%.

Per condizioni applicative differenti è necessario calcolare il carico equivalente: il carico che bisognerebbe applicare in condizioni standard per avere gli stessi effetti di scambio termico e usura che il carico reale sortisce nelle reali condizioni di utilizzo.

Pertanto è opportuno calcolare il carico equivalente come da formula seguente:

$$C_e = C \cdot f_g \cdot f_a \cdot f_d$$

### UNIT LOAD

Depending on the number of screw jacks in the system diagram, the load per screw jack can be calculated by dividing the total load by the number of screw jacks that contribute to driving the system.

If the load is not equally distributed between all screw jacks, the most stressed transmission must be considered. According to this value, by reading the descriptive tables, an initial selection can be made by choosing from the sizes with a permissible capacity value above the unit load.

### EQUIVALENT LOAD - DHT series

All values for the DHT series given in the catalogue refer to use under standard conditions, i.e. with a temperature of 20°C and an operating rate of 10%.

For different application conditions, it is necessary to calculate the equivalent load: this is the load that would have to be applied under standard conditions in order to have the same heat exchange and wear effects that the real load would have under real conditions of use.

Therefore, the equivalent load should be calculated as per the following formula:

### EQUIVALENT LOAD - HS series

All values given in the catalogue refer to use under standard conditions, i.e. with a temperature of 20°C and regular, shock-free operation for 8 hours a day.

Use under these conditions is expected to last 10'000 hours with a service rate of 70%.

For different application conditions, it is necessary to calculate the equivalent load: this is the load that would have to be applied under standard conditions in order to have the same heat exchange and wear effects that the real load would have under real conditions of use.

Therefore, the equivalent load should be calculated as per the following formula:

Definizione dei carichi

Definition of loads

CARICHI RADIALI

Nel caso ci siano carichi radiali sulla vite senza fine è necessario verificare la resistenza degli stessi secondo quanto riportato nella tabella sottostante.

Nei casi in cui i valori di carico radiale effettivo eccedessero i valori riportati in tabella, è necessario scegliere una taglia superiore.

RADIAL LOADS

If there are radial loads on the worm screw, it is necessary to check their resistance according to the table below. In cases where the actual radial load values exceed the values given in the table, a larger size must be chosen.

Serie DHT / DHT Series											
Taglia Size	183/184	204	306	407	559	609	7010	8010	9010	12014	16016
$F_{rv}$ [daN]	10	22	45	60	60	60	90	90	90	250	300

Serie HS / HS Series			
Taglia Size	70	100	120
$F_{rv}$ [daN]	450	600	900

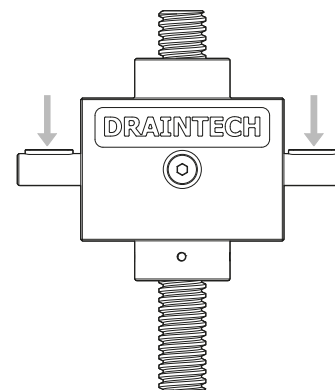

MOMENTO TORCENTE

TORQUE

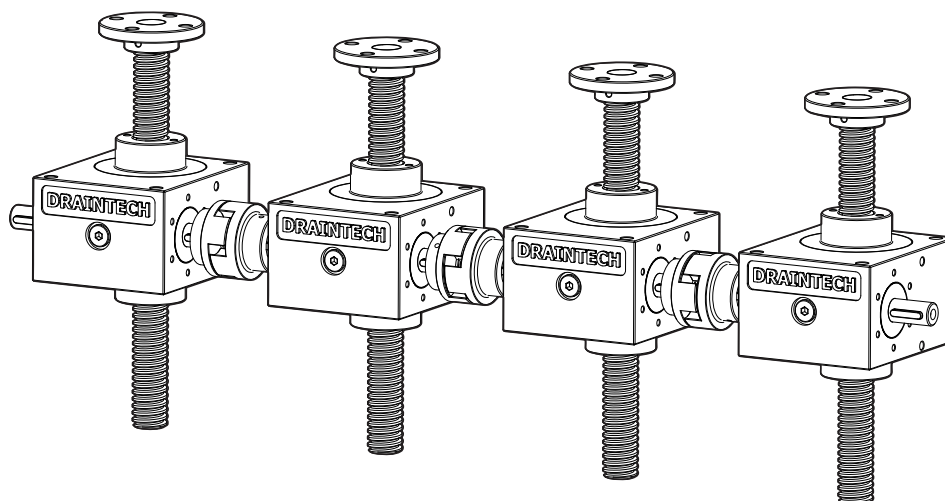

Serie DHT / DHT Series												
		Taglia / Size										
		183/184	204	306	407	559	609	7010	8010	9010	12014	16016
$M_{tvmax}$ [daNm]	Rapporto veloce Quick ratio	2.3	5.43	6.9	49.0	49.0	49.0	84.7	84.7	84.7	-	-
	Rapporto normale Normal ratio	2.3	5.43	15.4	12.8	12.8	-	-	-	-	522	823
	Rapporto lento Slow ratio	-	4.18	18.3	15.4	15.4	15.4	49.0	49.0	49.0	441	948

Serie HS / HS Series				
		Taglia / Size		
		70	100	120
$M_{tvmax}$ [daNm]		31.5	61.5	109

Nel caso tali valori venissero superati è necessario scegliere una taglia superiore, cambiare lo schema dell'impianto o aumentare la velocità, compatibilmente con quanto riportato nei paragrafi precedenti.

If these values are exceeded, it is necessary to choose a larger size, change the system layout or increase the speed, consistent with the previous paragraphs.

### CARICO LATERALE

Come riportato nei paragrafi precedenti i carichi laterali sono la principale causa di guasti. Essi, oltre ad essere causati da un disallineamento tra asta filettata e carico, possono derivare da montaggi imprecisi che costringono l'asta filettata in una posizione anomala.

Di conseguenza il contatto tra asta filettata e chiodo per il modello R e tra asta filettata e ruota elicoidale per il modello T, risulterà scorretto.

L'impiego di doppie guide permette, per i modelli T, una parziale correzione della posizione anomala dell'asta filettata prima di entrare in contatto con la ruota elicoidale. Il problema si trasforma in uno strisciamento dell'asta filettata sulle guide stesse.

Nel modello R, è la madrevite esterna che entra in contatto con l'asta filettata e pertanto non è possibile portare delle correzioni, se non applicando dei montaggi particolari come approfondito nel paragrafo "gioco laterale nei modelli R". Carichi laterali possono derivare anche da un montaggio orizzontale: il peso proprio dell'asta filettata causa una flessione della stessa trasformandosi così in un carico laterale.

Il valore limite della flessione e del conseguente carico laterale è in funzione della grandezza del martinetto e della lunghezza dell'asta filettata.

È consigliabile contattare l'Ufficio Tecnico e prevedere opportuni supporti.

I grafici sottostanti, validi per carichi statici, riportano in funzione della taglia e della lunghezza dell'asta filettata, il valore del carico laterale ammissibile.

Per applicazioni dinamiche è indispensabile interpellare l'Ufficio Tecnico.

### SIDE LOAD

As mentioned in the previous paragraphs, side loads are the main cause of failures. In addition to being caused by a misalignment between the threaded rod and the load, they can result from inaccurate assembly that forces the threaded rod into an abnormal position.

As a result, the contact between threaded rod and nut for the R model, and between threaded rod and helical gear for the T model, will be incorrect.

The use of double guides allows, for T-models, a partial correction of the abnormal position of the threaded rod before it makes contact with the helical gear. The problem becomes sliding of the threaded rod on the guides themselves.

In the R-model, it is the outer nut that makes contact with the threaded rod and therefore no corrections can be made, except by applying special mountings as detailed in the section on 'side backlash in R-models'. Side loads can also result from horizontal installation: the very weight of the threaded rod causes it to bend, thus becoming a side load.

The limit value of the bending and the resulting side load is a function of the screw jack size and the length of the threaded rod.

It is advisable to contact the Technical Department and provide appropriate support.

The graphs below, which are valid for static loads, show the value of the admissible side load depending on the size and length of the threaded rod.

For dynamic applications it is essential to consult the Technical Department.

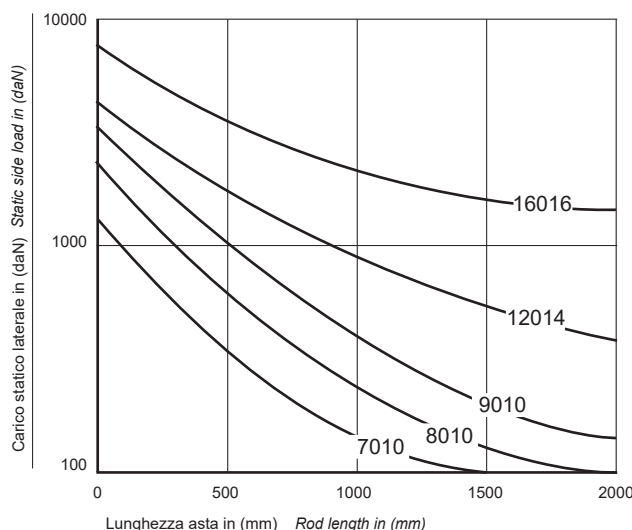
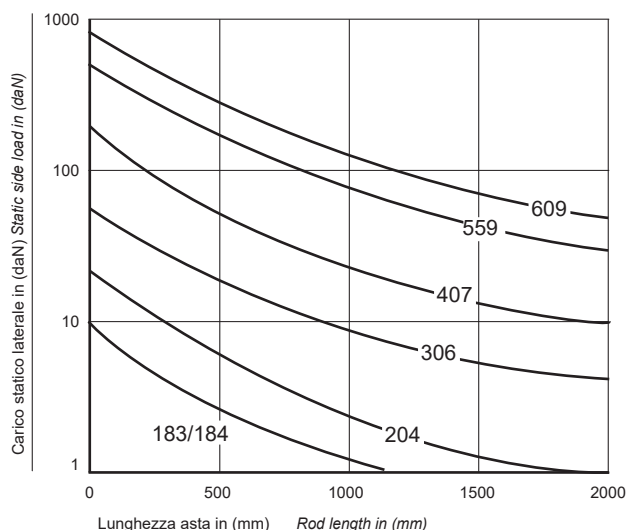

Qualora la dimensione scelta nei paragrafi precedenti non sia sufficiente al sostegno di un determinato carico laterale è necessario scegliere una grandezza idonea o meglio prevedere, ove possibile, un supporto specificatamente progettato per compensare e sostenere il carico laterale.

If the size chosen in the previous paragraphs is not sufficient to support a given side load, a suitable size must be chosen or, where possible, a support specifically designed to compensate for and support the side load.

**VERIFICA A CARICO DI PUNTA**

Qualora il carico si presenti, anche una sola volta nella vita del martinetto, a compressione, è necessario verificare il martinetto a carico di punta.

Per prima cosa è necessario individuare i due vincoli che sostengono il martinetto:

- il primo si trova sul terminale nei modelli T e sulla chiocciola nei modelli R;
- il secondo dipende dal modo in cui la scatola martinetto risulta essere vincolata alla struttura della macchina.

Nella maggior parte dei casi reali è possibile schematizzare secondo tre modelli descritti di seguito:

**PEAK LOAD VERIFICATION**

*If the load occurs, even once in the life of the screw jack, in compression, the screw jack must be tested at peak load.*

*First, it is necessary to identify the two elements that support the screw jack:*

- *the first is located on the terminal in T-models and on the nut in R-models;*
- *the second depends on the way the screw jack box is constrained to the machine structure.*

*In most real-life cases, it is possible to simplify according to three models described below:*

	Condizioni di vincolo / Securing conditions	
	Terminale - Chiocciola Terminal - Nut	Martinetto Screw jack
<b>EULERO I</b>	Libero / Free	Incastrato / Fitted
<b>EULERO II</b>	Cerniera / Hinge	Cerniera / Hinge
<b>EULERO III</b>	Manicotto / Sleeve	Incastrato / Fitted

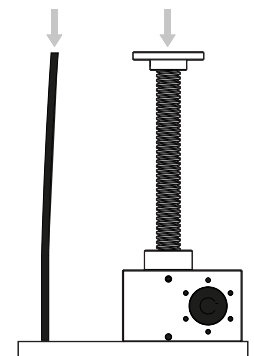
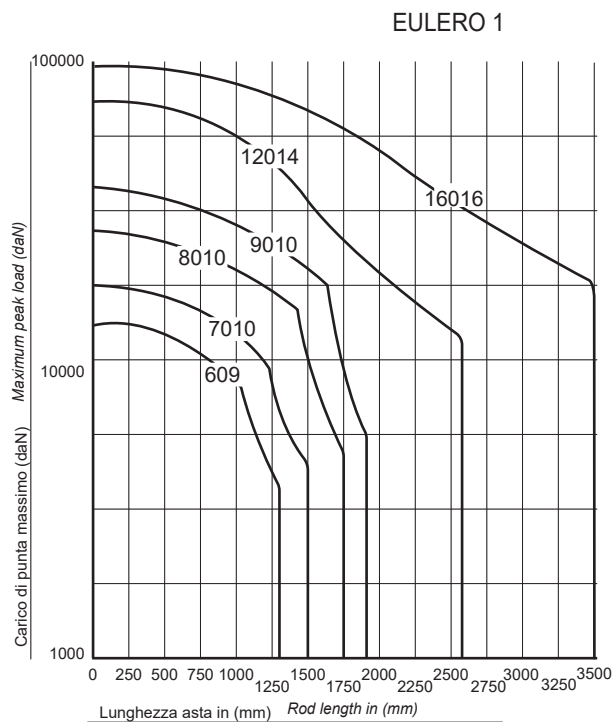
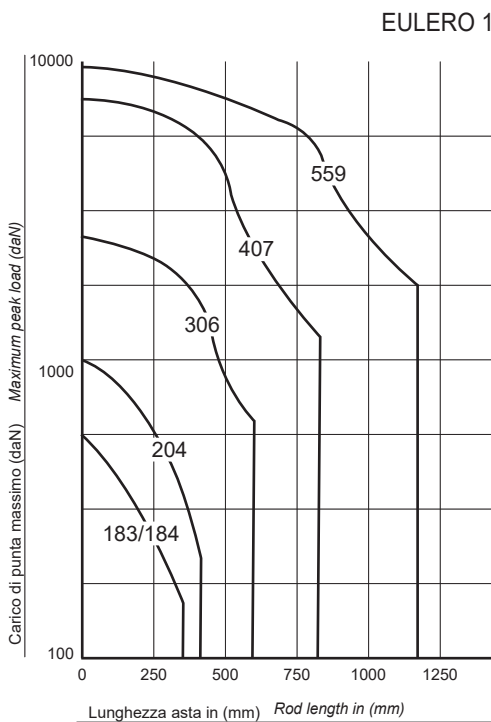

Definizione dei carichi

Definition of loads

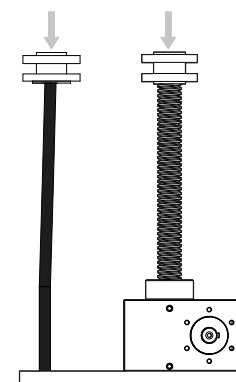
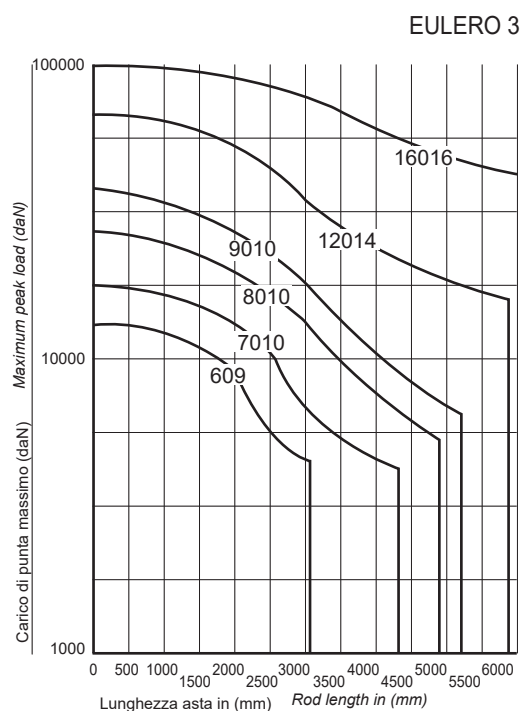
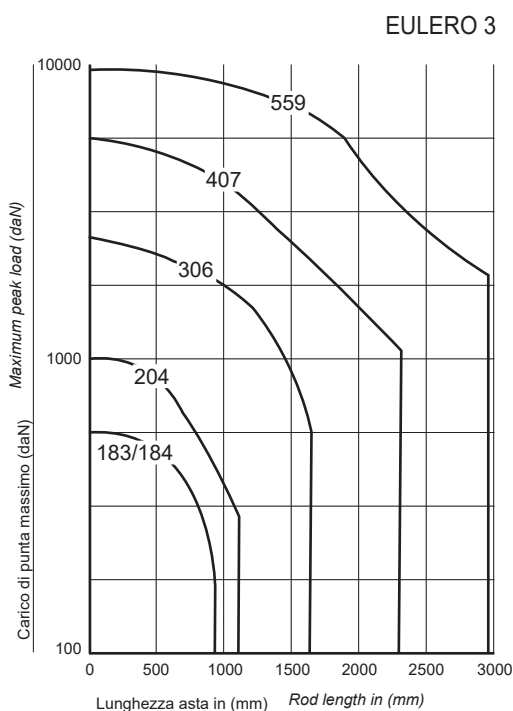
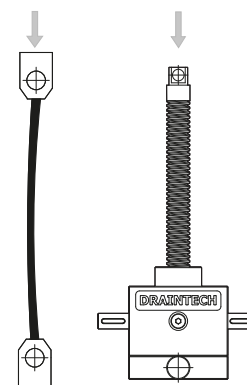
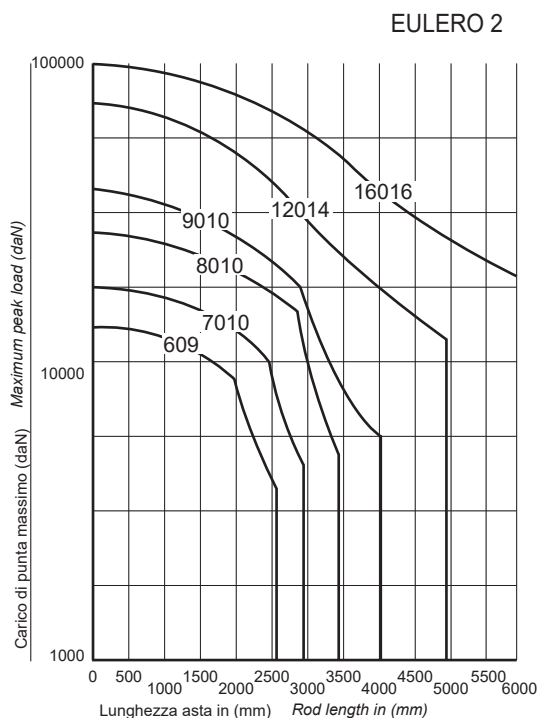
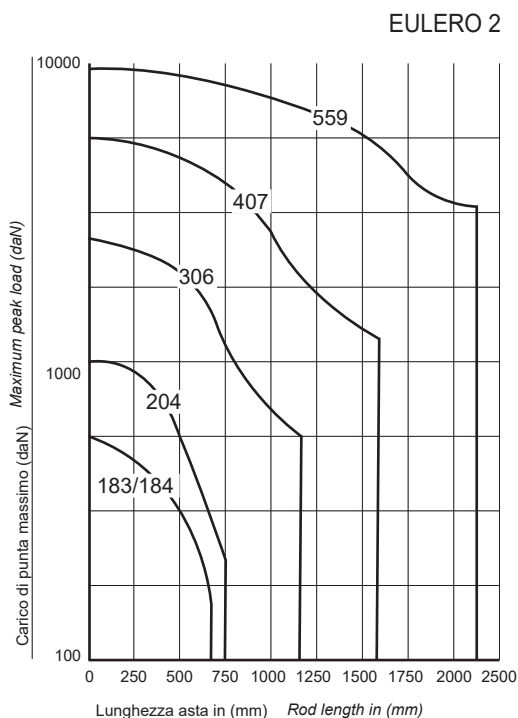

Una volta individuato la configurazione EULERO che più si avvicina all'applicazione in analisi, bisogna trovare nel relativo grafico, il punto corrispondente alle coordinate (lunghezza; carico).

Le grandezze adatte all'applicazione sono quelle le cui curve sottendono il punto di cui sopra.  
Qualora la grandezza scelta non rispettasse tale requisito è necessario considerare la taglia superiore.  
Le curve di EULERO sono state calcolate con un coefficiente di sicurezza pari a 4.  
Per applicazioni che debbano considerare coefficienti di sicurezza inferiori a 4 contattare l'Ufficio Tecnico.

Once the EULERO configuration closest to the application under analysis has been identified, the point corresponding to the coordinates (length; load) must be found in the relevant graph.

The quantities suitable for application are those whose curves are stated in the above point.  
If the chosen size does not meet this requirement, the larger size must be considered.  
EULERO curves were calculated with a safety factor of 4.  
For applications where safety coefficients of less than 4 have to be considered, please contact the Technical Department.

### GIOCO D'INGRANAMENTO TRA VITE SENZA FINE E CORONA ELICOIDALE

L'accoppiamento vite senza fine/ruota elicoidale presenta un gioco di alcuni gradi. Per effetto del rapporto di riduzione del martinetto e della trasformazione del moto da rotatorio a traslatorio, questo gioco si traduce in un errore di posizionamento lineare dell'asta.

### GIOCO LATERALE NEI MODELLI T

L'accoppiamento dell'asta filettata con la ruota elicoidale presenta un naturale e necessario gioco laterale, indicato con A nel disegno sottostante.

Le guide presenti sui martinetti di serie consentono di ridurre al minimo l'entità di tale gioco, mantenendo allineati gli assi di asta e madrevite. Il gioco laterale A sull'accoppiamento si traduce sul terminale dell'asta in una misura lineare il cui valore dipende dalla taglia del martinetto ed è funzione crescente della lunghezza dell'asta stessa.

### GIOCO LATERALE NEI MODELLI R

Nei modelli R asta e ruota elicoidale sono solidali per effetto di uno specifico dispositivo che blocca l'asta alla ruota.

Questo dispositivo e la sua installazione sono stati sviluppati dalla DRAINTECH in modo da rendere concentrici e perfettamente allineati gli assi di rotazione della vite trapezia o a ricircolo e della ruota dentata da cui prendono il moto. Esiste comunque un disallineamento tra asse della vite e asse della ruota dentata dovuto alle tolleranze di lavorazione dei singoli componenti. Se queste oscillazioni, seppur ridotte al minimo, non fossero tollerabili da una specifica applicazione, è necessario che l'utilizzatore adotti accorgimenti tali da mantenere l'allineamento tra asta e chiocciola.

Le guide possono essere esterne o coinvolgere direttamente la struttura della chiocciola.

### GIOCO ASSIALE

Il gioco assiale B tra asta filettata e la sua madrevite (sia essa ruota elicoidale o chiocciola) è causato dalla naturale e necessaria tolleranza di questo tipo di accoppiamento.

Ai fini costruttivi esso è rilevante solo in caso in cui il carico cambi il verso di applicazione. Per applicazioni in cui ci sia un'alternanza di carichi a trazione e a compressione e una necessità di compensare il gioco assiale, è possibile impiegare un sistema di recupero del gioco.

### COUPLING BETWEEN WORM SCREW AND HELICAL GEAR

*The worm screw/helical gear coupling has a backlash of a few degrees.*

*Due to the reduction ratio of the screw jack and the transformation of motion from rotation to translation, this backlash results in a linear positioning error of the rod.*

### SIDE BACKLASH IN T MODELS

*The coupling of the threaded rod with the helical gear presents a natural and necessary side backlash, indicated by A in the drawing below.*

*The guides on the standard screw jacks minimise the amount of this backlash, keeping the axes of the rod and nut aligned. The side backlash A on the coupling translates at the rod end into a linear measurement whose value depends on the size of the screw jack and is an increasing function of the length of the rod.*

### SIDE PLAY IN R MODELS

*In the R models, the rod and helical gear are joined by a specific device that locks the rod to the wheel.*

*This device and its installation have been developed by DRAINTECH in such a way that the rotational axes of the trapezoidal or recirculating screw and the toothed gear that drive them are concentric and perfectly aligned.*

*However, there is a misalignment between the screw axis and the toothed gear axis due to the machining tolerances of the individual components. If these oscillations, although minimised, cannot be tolerated by a specific application, the user must take steps to maintain alignment between the rod and the nut.*

*The guides can be external or directly involve the nut structure.*

### AXIAL BACKLASH

*The axial backlash B between the threaded rod and its nut (be it helical gear or nut) is caused by the natural and necessary tolerance of this type of coupling.*

*For construction purposes it is only relevant if the load changes direction of application. For applications where there is an alternation of tensile and compressive loads and a need to compensate for axial backlash, a backlash recovery system can be used.*

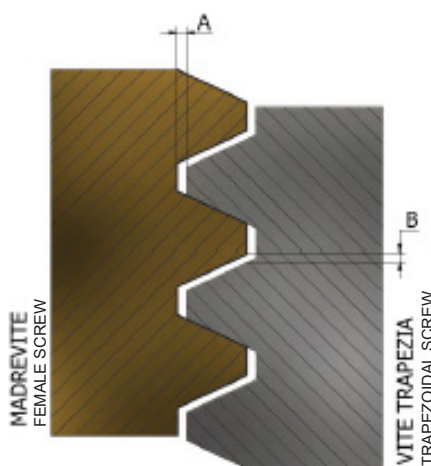

**SERIE DHT**

La lubrificazione degli organi interni di trasmissione e dei cuscinetti è a grasso.  
Tale prodotto garantisce la lubrificazione a vita del martinetto.

Il grasso impiegato su tutte le taglie è l'ENI GREASE 33/FD. Sono previsti, ad ogni modo, tappi di carico su tutte le grandezze per consentire l'eventuale rabbocco di lubrificante. Sono disponibili a richiesta grassi per condizioni particolari di impiego come alimentare, basse temperature e per alte temperature.

Di seguito riportiamo le specifiche tecniche del grasso base utilizzato.

**DHT SERIES**

*Lubrication of the internal transmission parts and bearings is grease-based.  
This product guarantees lifetime lubrication of the screw jack.*

*The grease used on all sizes is ENI GREASE 33/FD. In any case, filler plugs are provided on all sizes to allow for any refilling of lubricant. Greases for special application conditions such as foodstuffs, low temperatures and for high temperatures are available on request.*

*Below are the technical specifications of the base grease used.*

Lubrificante Lubricant	Campo d'impiego Field of application	Temperatura di utilizzo Operating temperature [° C]	Normative tecniche Technical standards
ENI GREASE 33/FD	Standard	- 10 - +160 *	ASTM D 4950 GA DIN 51825 K 3N-10 ISO 12924 L-XADGA 3

\* per temperature d'esercizio comprese tra 80 °C e 150 °C utilizzare guarnizioni in VITON  
per temperature inferiori a -20 °C e superiori a 150 °C contattare l'Ufficio Tecnico

*\* for operating temperatures between 80 °C and 150 °C use VITON gaskets  
for temperatures below -20 °C and above 150 °C please contact Technical Department*

Altre tipologie di grasso possono utilizzarsi a seconda dell'impiego come di seguito indicato.

*Other types of grease can be used depending on the application as indicated below.*

Lubrificante Lubricant	Campo d'impiego Field of application	Temperatura di utilizzo Operating temperature [° C]	Normative tecniche Technical standards	Note Notes
AGIP GR MU EP2	Standard Standard	- 15 - +130	ISO: L-X-BCHB 2 DIN 51825: KP2 -20 P-64	
TOTAL CARTER EP 2200	Standard Standard	0 - +150	AGMA 9005: D94 DIN 51517-3 CLP-US STEEL 224	non compatibile con olii a base di poliglicoli <i>not compatible with polyglycol-based oils</i>
TOTAL NEVASTANE EP 1000	Alimentare Food grade	0 - +130	NSF-USDA: H1	
ENI RUBUS TF2	Alimentare Food grade	- 15 - +120	ISO 12924-L-XACDB 2	
ENI GREAE LCX 2/32 EP2	Basse temperature Low temperatures	- 50 - +140	ISO 12924-L-XEDHB 2 DIN 51825 KPHC 2N-50	
ENI NF2	Alte temperature High temperatures	- 10 - +140	ISO 12924-L-XADGA 2	

I soli martinetti forniti con le PE (protezioni elastiche) già montate in fabbrica sono precedentemente ingrassate. E' importante, in questi tipi di martinetti, essendo le aste trapezoidali non visibili, che l'operatore segua scrupolosamente la manutenzione ingrassando periodicamente l'asta come da manuale di uso e manutenzione.

*Only screw jacks supplied with PE (elastic guards) already fitted at the factory are previously greased. It is important with these types of screw jacks, as the trapezoidal rods are not visible, that the operator scrupulously follows the maintenance by periodically greasing the rod as per the operation and maintenance manual.*

Di seguito le quantità di lubrificante contenute nei martinetti.

*Below are the quantities of lubricant contained in the screw jacks.*

Taglia Size	183/184	204	306	407	559	609	7010	8010	9010	12014	16016
Quantità di lubrificante Quantity of lubricant [kg]	0.06	0.1	0.3	0.6	1	1	2	2	2.3	3.7	14

**SERIE HS**

**HS SERIES**

**Lubrificazione interna**

**Internal lubrication**

La lubrificazione dei martinetti standard è ad olio sintetico viscosità 320. Possono essere installati in qualunque posizione di montaggio e non necessitano di manutenzione.

*The standard screw jacks are lubricated with synthetic oil viscosity 320. They can be installed in any mounting position and are maintenance-free.*

Riportiamo nella tabella seguente le specifiche tecniche del lubrificante base utilizzato.

*The table below shows the technical specifications of the base lubricant used.*

Lubrificante <i>Lubricant</i>	Campo d'impiego <i>Field of application</i>	Temperatura di utilizzo <i>Operating temperature</i> [° C]	Normative tecniche <i>Technical standards</i>
SHELL OMALA S4 WE320	Standard <i>Standard</i>	-25° - +160°	

Di seguito le quantità di lubrificante contenute nei martinetti.

*Below are the quantities of lubricant contained in the screw jacks.*

Taglia <i>Size</i>	70	100	120
Quantità di lubrificante <i>Quantity of lubricant</i> [kg]	0.06	0.1	0.3

**Lubrificazione asta a ricircolo di sfere**

**Ball rod lubrication**

La lubrificazione dell'asta a ricircolo di sfere è a cura dell'utilizzatore e deve essere effettuata con un lubrificante adesivo consigliato dal costruttore.

*Lubrication of the ball rod is the responsibility of the user and must be carried out with an adhesive lubricant recommended by the manufacturer.*

La lubrificazione dell'asta a ricircolo di sfere è fondamentale e determinante per il corretto funzionamento del martinetto. Deve essere eseguita ad intervalli tali da garantire sempre uno strato di lubrificante pulito tra le parti in contatto. La carenza di lubrificante o una cattiva manutenzione possono provocare un riscaldamento anomalo e conseguenti fenomeni di usura così marcati da ridurre sensibilmente la vita utile del martinetto.

*Lubrication of the ball rod is essential and crucial for the proper functioning of the screw jack. It must be carried out at such intervals as to always ensure a clean layer of lubricant between the contact parts. Lack of lubricant or poor maintenance can lead to abnormal heating and consequent wear phenomena so pronounced that the screw jack's service life is significantly reduced.*

Qualora i martinetti non fossero visibili oppure le aste a ricircolo di sfere siano ricoperte da protezioni è indispensabile verificare periodicamente lo stato della lubrificazione.

*If the screw jacks are not visible or the ball rods are covered by guards, it is essential to periodically check the lubrication status.*

**DATI DELL'APPLICAZIONE**

Per un corretto dimensionamento dei martinetti è necessario individuare i dati dell'applicazione:

**Carico [daN]**

Si identifica il carico come la forza applicata all'organo traslante del martinetto. Normalmente il dimensionamento si calcola considerando il massimo carico possibile applicato al martinetto. Il carico è scomponibile in vettori che ne definiscono direzione, verso ed entità.

**Velocità di traslazione [mm/min]**

La velocità di traslazione è la velocità con cui si desidera movimentare il carico. Da questa si possono ricavare la velocità di rotazione degli organi rotanti e la potenza necessaria alla movimentazione. E' buona norma limitare la velocità di traslazione in modo da non superare i 1500 rpm in entrata sulla vite senza fine. Sono possibili utilizzi fino a 3000 rpm in ingresso, ma in questi casi è consigliabile contattare il nostro servizio Tecnico.

**Corsa [mm]**

Rappresenta la misura lineare di quanto si desidera movimentare il carico e non coincide con la lunghezza totale dell'asta filettata.

**Variabili d'ambiente**

Sono valori che identificano l'ambiente e le condizioni in cui opera il martinetto.

Le principali sono: temperatura, fattori ossidanti o corrosivi, tempi di lavoro e di fermo, vibrazioni, manutenzione e pulizia, quantità e qualità della lubrificazione etc.

**Struttura dell'impianto**

Esistono infiniti modi di movimentare un carico utilizzando martinetti. Gli schemi a pagina B9-B16 ne riportano alcuni esempi. La scelta dello schema di impianto condizionerà la scelta della taglia e della potenza necessaria all'applicazione.

**APPLICATION DATA**

*For correct dimensioning of the screw jacks, it is necessary to identify the application data:*

**Load [daN]**

*The load is identified as the force applied to the translating part of the screw jack. Normally, sizing is calculated considering the maximum possible load applied to the screw jack. The load is broken down into vectors that define its direction, side and magnitude.*

**Travel speed [mm/min]**

*The travel speed is the speed at which you want to move the load. The rotational speed of the rotating parts and the power required for movement can be derived from this. It is a good idea to limit the translation speed so as not to exceed 1500 rpm at the worm gear input. Operation up to 3000 rpm input is possible, but in these cases it is advisable to contact our Technical Service.*

**Stroke [mm]**

*This represents a linear measure of how much you want to move the load and is not the same as the total length of the threaded a-stem.*

**Environment variables**

*These are values that identify the environment and conditions in which the screw jack operates.*

*The main ones are: temperature, oxidising or corrosive factors, working and downtime, vibration, maintenance and cleaning, quantity and quality of lubrication, etc.*

**System structure**

*There are infinite ways of moving a load using screw jacks. The diagrams on pages B9-B16 show some examples. The choice of system scheme will condition the choice of size and power required for the application.*

Per un corretto dimensionamento del martinetto è necessario procedere seguendo le indicazioni sotto riportate:

For correct dimensioning of the screw jack, it is necessary to proceed according to the instructions below:

SERIE DHT

DHT SERIES

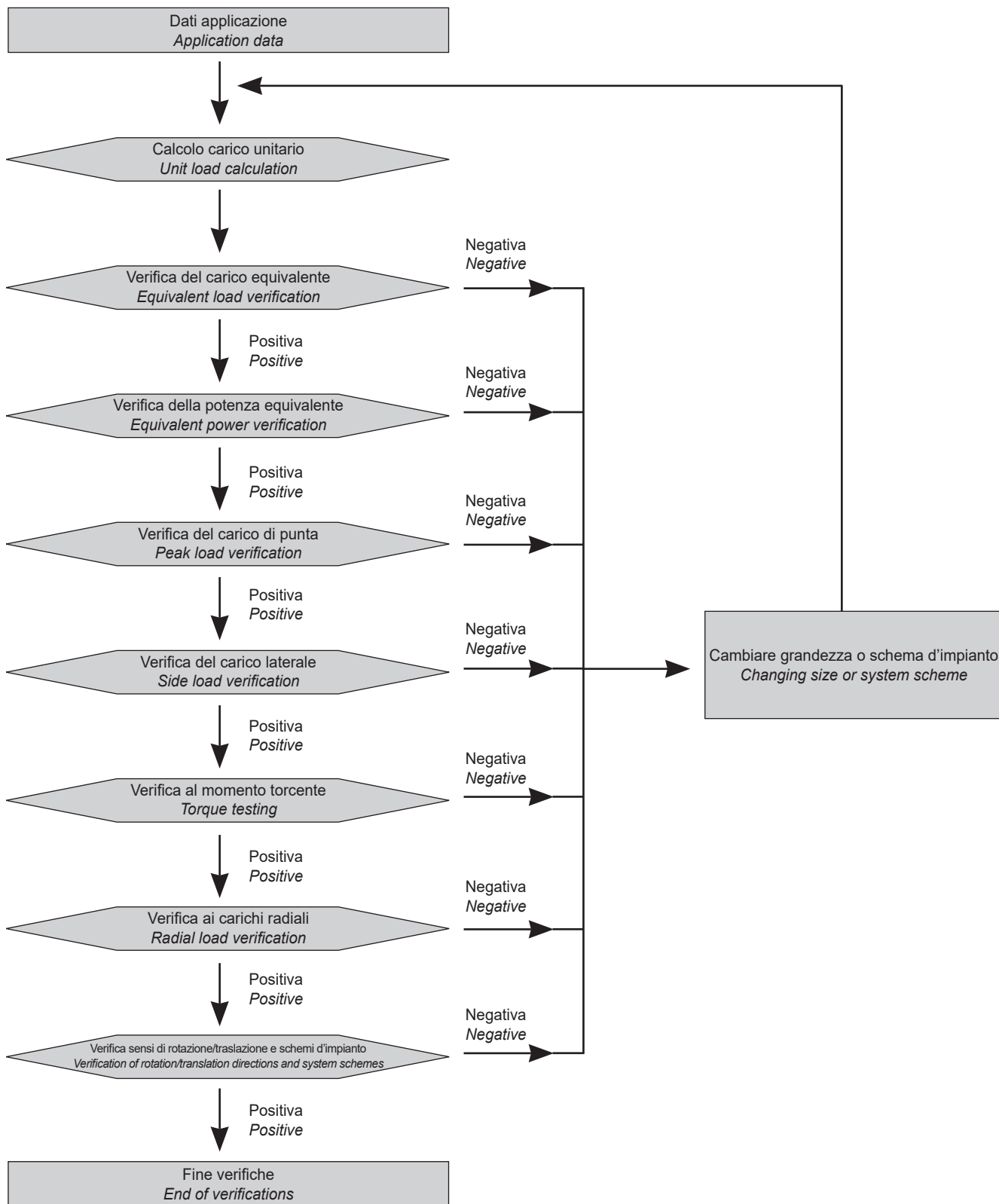

**Fattore di temperatura  $f_t$**

Tramite l'utilizzo del grafico sottostante si può calcolare il fattore  $f_t$  in funzione della temperatura ambiente.

Per temperature superiori a 80 °C è necessario contattare l'Ufficio Tecnico.

**Temperature factor  $f_t$**

Using the graph below, one can calculate the  $f_t$  factor as a function of room temperature.

For temperatures above 80 °C it is necessary to contact the Technical Department.

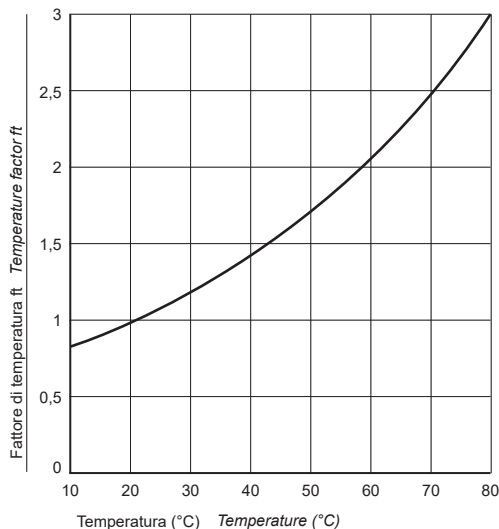

**Fattore ambiente  $f_a$**

Tramite l'utilizzo della tabella sottostante si può determinare il fattore  $f_a$  in funzione delle condizioni d'utilizzo.

**Environment factor  $f_a$**

Using the table below, the  $f_a$  factor can be determined according to the conditions of use.

Tipologia del carico <i>Type of load</i>	Fattore ambiente <i>Environment factor</i> $f_a$
Urti leggeri, poche inserzioni, movimenti regolari <i>Light impacts, few insertions, regular movements</i>	1
Urti medi, frequenti inserzioni, movimenti regolari <i>Medium impacts, frequent insertions, regular movements</i>	1.2
Urti forti, numerose inserzioni, movimenti irregolari <i>Strong impacts, numerous insertions, irregular movements</i>	1.8

**Fattore di servizio  $f_s$  - serie DHT**

Il fattore di servizio  $f_s$  si ottiene valutando il ciclo di lavoro e calcolando la percentuale di funzionamento su tale intervallo.

Ad esempio un tempo di lavoro di 5 minuti e un tempo di sosta di 5 minuti sono pari ad un 50%; analogamente un tempo di lavoro di 5 minuti e 20 minuti di sosta equivalgono a un 20%. In base ai dati di esercizio, scegliendo il tempo di ciclo e la percentuale di servizio si può leggere in ordinata il valore di  $f_s$ .

**Service factor  $f_s$  - DHT series**

The service factor  $f_s$  is obtained by evaluating the work cycle and calculating the percentage of operation over that range.

For example, a work time of 5 minutes and a rest time of 5 minutes equals 50%; similarly, a work time of 5 minutes and a rest time of 20 minutes equals 20%. Based on the operating data, by choosing the cycle time and the service percentage, the value of  $f_s$  can be read off in the timeline.

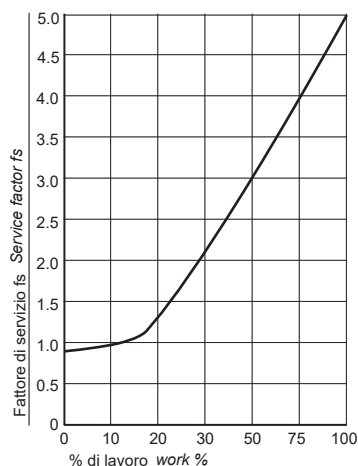

Una volta calcolato il carico equivalente, con l'ausilio delle tabelle descrittive si può verificare se la grandezza scelta in precedenza sia in grado di sostenere un carico dinamico ammissibile di valore pari al carico equivalente.

Once the equivalent load has been calculated, it can be verified with the help of the descriptive tables whether the previously chosen size is capable of supporting an admissible dynamic load of a value equal to the equivalent load.

**Tabelle di potenza e potenza equivalente**

Le tabelle di potenza sono riportate nelle pagine relative alle caratteristiche di ogni taglia di martinetto. Scegliendo quelle relative alla grandezza selezionata, sulla base del carico statico riportato nella tabella di pagina B4, ed entrando in tabella con i valori del carico equivalente e della velocità di traslazione, si può ottenere il valore della potenza equivalente.

**Power and equivalent power tables**

Power tables can be found on the characteristics pages for each screw jack size. By choosing those for the selected size, based on the static load given in the table on page B4, and entering the equivalent load and travel speed values in the table, the equivalent power value can be obtained.

Se tale incrocio di valori cade nella zona colorata in rosso, significa che le condizioni applicative potrebbero causare fenomeni negativi quali surriscaldamento e usure marcate. Pertanto è necessario ridurre la velocità di traslazione o salire di grandezza.

If the values intersect in the red-coloured area, this means that application conditions could cause negative phenomena such as overheating and marked wear. Therefore it is necessary to reduce the translation speed or go up in size. The equivalent power is not the power required by the individual screw jack, unless the three correction factors  $f_t$ ,  $f_a$  and  $f_s$  have unit values.

La potenza equivalente non è la potenza richiesta dal singolo martinetto, a meno che i tre fattori correttivi  $f_t$ ,  $f_a$  e  $f_s$  non abbiano valore unitario.

Dimensionamento del martinetto

Screw jack sizing

Per un corretto dimensionamento del martinetto è necessario procedere seguendo le indicazioni sotto riportate:

For correct dimensioning of the screw jack, it is necessary to proceed according to the instructions below:

SERIE HS

HS SERIES

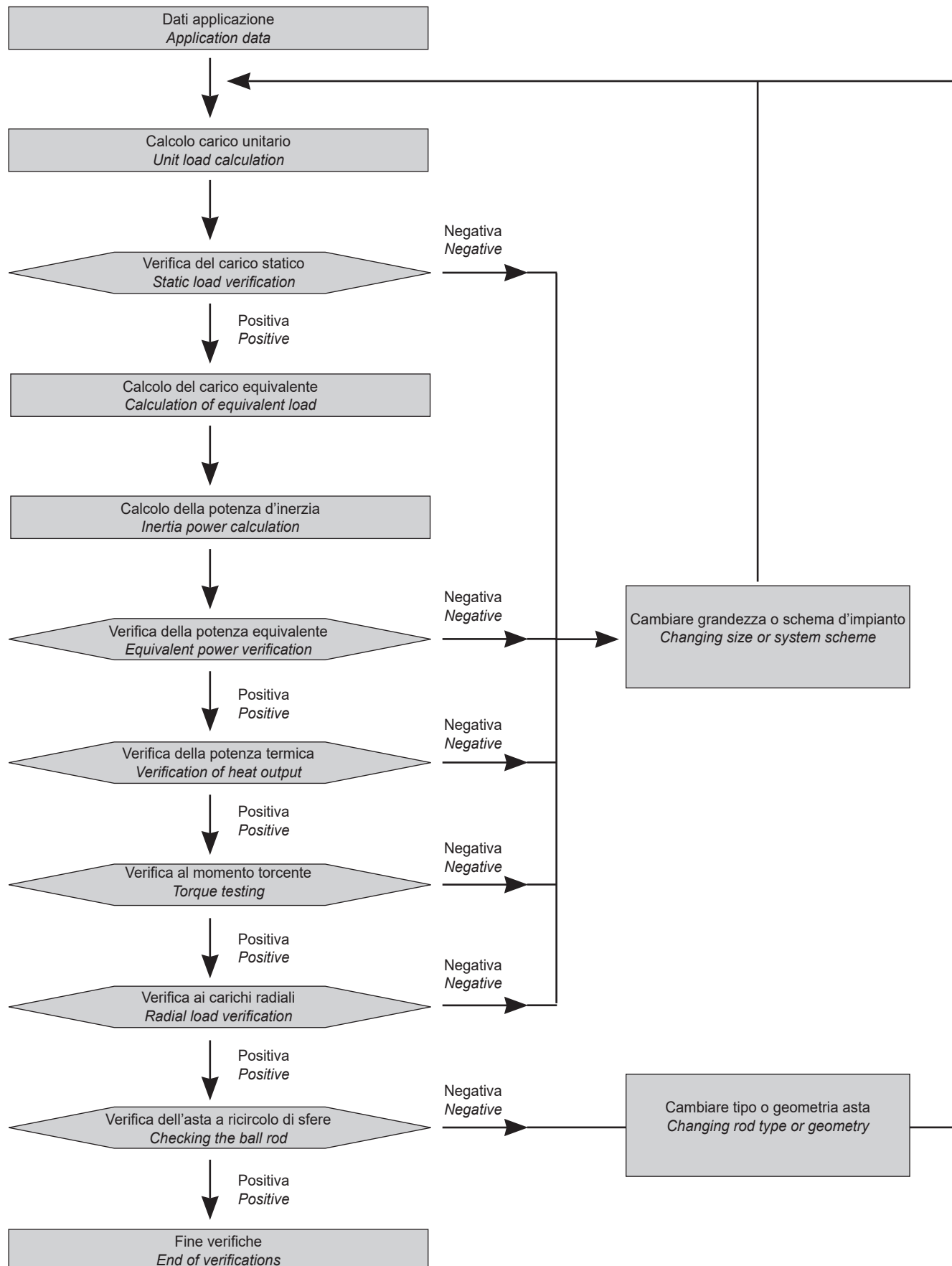

**Fattore di utilizzo  $f_g$  - serie HS**

Tramite l'utilizzo del grafico sottostante si può calcolare il fattore di utilizzo  $f_g$  in funzione delle ore lavorative su base giornaliera.

**Utilisation factor  $f_g$  - HS series**

Using the graph below, the utilisation factor  $f_g$  can be calculated as a function of working hours on a daily basis.

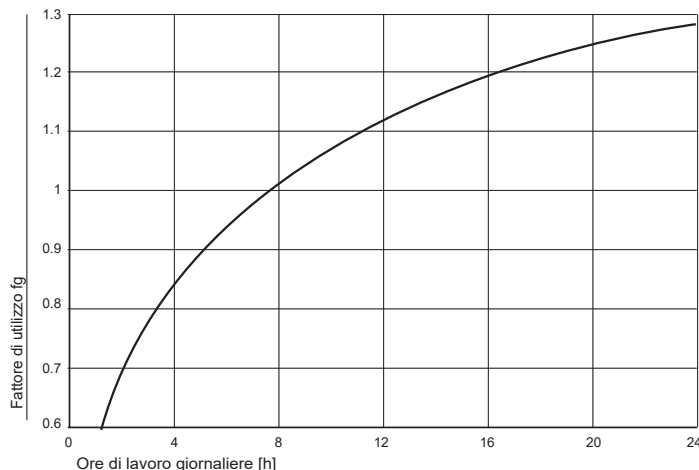

**Fattore d' ambiente  $f_a$**

Tramite l'utilizzo della tabella sottostante si può calcolare il fattore  $f_a$  in funzione delle condizioni di esercizio.

**Environment factor  $f_a$**

Using the table below, the  $f_a$  factor can be calculated as a function of operating conditions.

Fattore ambiente / Environment factor			
Tipologia del carico Type of load	$f_a$		
	Ore di lavoro giornaliere / Daily working hours [h]		
	3	8	24
Urti leggeri, poche inserzioni, movimenti regolari Light impacts, few insertions, regular movements	0.8	1	1.2
Urti medi, frequenti inserzioni, movimenti regolari Medium impacts, frequent insertions, regular movements	1	1.2	1.5
Urti forti, numerose inserzioni, movimenti irregolari Strong impacts, numerous insertions, irregular movements	1.2	1.8	2.4

**Fattore di durata  $f_d$**

Il fattore di durata  $f_d$  si calcola in funzione della vita utile teorica prevista (espressa in ore).

**Duration factor  $f_d$**

The service life factor  $f_d$  is calculated as a function of the expected theoretical service life (expressed in hours).

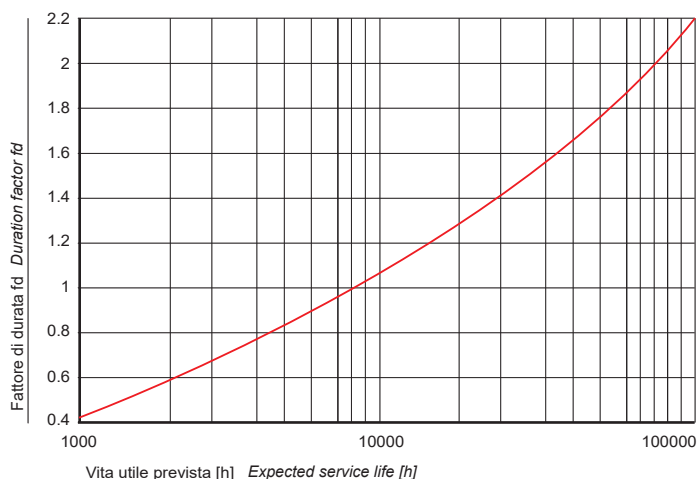

**Potenza d'inerzia  $P_j$**

In caso di presenza di accelerazioni e decelerazioni importanti e necessario procedere al calcolo della potenza di inerzia  $P_j$ . Il calcolo delle inerzie del sistema a valle del martinetto HS vite a ricircolo compresa, sono a carico dell'utilizzatore. A questo valore deve essere aggiunto l'inerzia del martinetto riportata nella tabella sottostante.

**Inertia power  $P_j$**

If there is significant acceleration and deceleration, the inertia power  $P_j$  must be calculated. The calculation of system inertias downstream of the HS screw jack, including the ball screw, is the responsibility of the user. The screw jack inertia shown in the table below must be added to this value.

$$P_j = \frac{2 \cdot J \cdot A^2 \cdot B}{91188}$$

	Taglia / Size		
	700	100	120
Inerzia del martinetto (senza vite a ricircolo) Screw jack inertia (without ball screw) [kgm <sup>2</sup> ]	0.004061	0.025498	0.079833

**Potenza equivalente  $P_e$**

La potenza equivalente ( $P_e$ ) in uscita al sistema martinetto - asta a ricircolo di sfere è ottenibile con la formula sottostante e permette il calcolo della potenza in ingresso al martinetto ( $P_{ei}$ )

**Equivalent power  $P_e$**

The equivalent output power ( $P_e$ ) of the screw jack - ball rod system can be obtained with the formula below and allows calculation of the screw jack input power ( $P_{ei}$ )

$$P_e = C_e \cdot v$$

$$P_{ei} = \frac{P_e}{\eta_a \cdot \eta_m} + P_j = \frac{C_e \cdot v}{\eta_a \cdot \eta_m} + P_j$$

Calcolata la potenza equivalente, selezionare la taglia del martinetto facendo riferimento alle tabelle alle pag. C8, C10 e C12. La potenza in ingresso al riduttore  $P_i$ , alla velocità di traslazione scelta, deve essere superiore a quella equivalente  $P_{ei}$ .

After calculating the equivalent power, select the screw jack size by referring to the tables on pages C8, C10 and C12. The input power to the gearbox, at the chosen travel speed, must be greater than the equivalent  $P_{ei}$ .

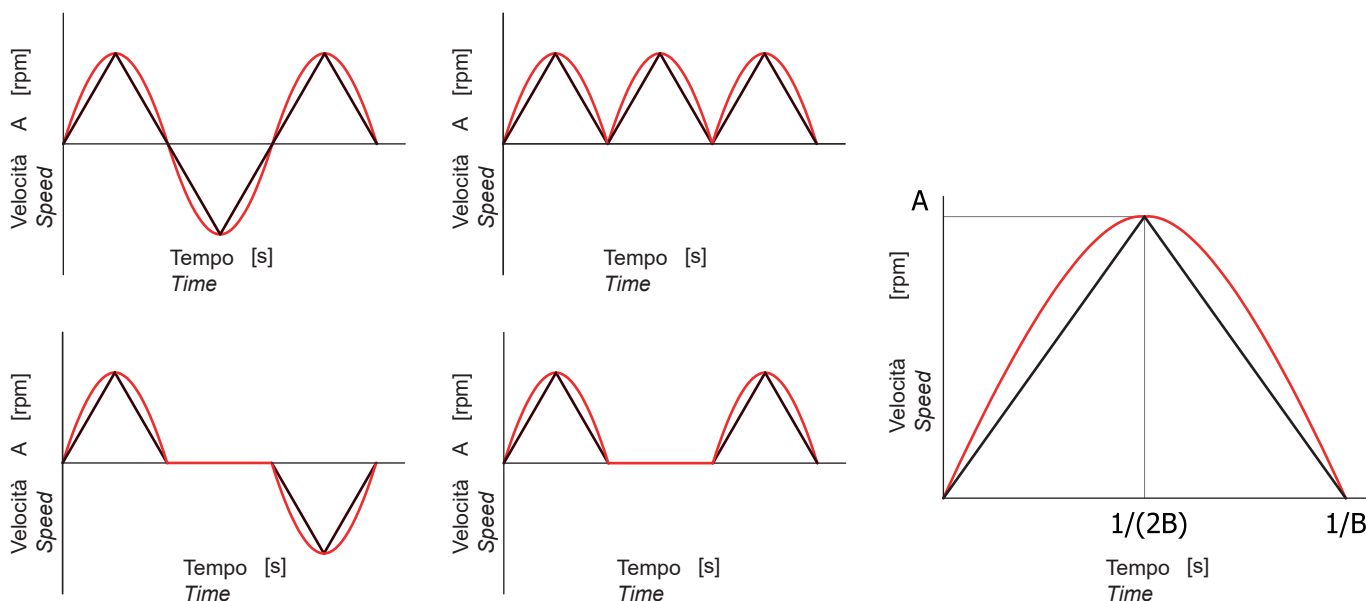

**Verifica dell'asta a ricircolo di sfere**

La scelta della vite a ricircolo deve essere fatta verificando che

- resista al carico statico e dinamico,
- che superi le verifiche di Eulero,
- che possa o meno sopportare carichi laterali,
- che possa sostenere i cicli di lavoro desiderati senza surriscaldarsi o cedere a fatica
- quant'altro il progetto possa richiedere.

Dafinita la velocità lineare di traslazione, la scelta del passo della vite deve essere fatta considerando di non superare la velocità consentita in ingresso al martinetto di 3000 rpm.

Nella tabella sottostante vengono riportati i valori massimi di velocità di traslazione in funzione al passo della vite.

**Checking the ball rod**

*The choice of ball screw must be made by checking that*

- *it withstands static and dynamic load,*
- *it passes the EULERO test,*
- *whether or not it can withstand side loads,*
- *that it can withstand the desired work cycles without over-heating or fatigue failure*
- *whatever else the project may require.*

*Having defined the linear speed of translation, the choice of screw pitch must be made considering not to exceed the permissible screw input speed of 3000 rpm.*

*The table below shows the maximum translation speed values as a function of the screw pitch.*

Passo vite a ricircolo di sfere Ball screw pitch	Velocità massima di traslazione a 3000 rpm [mm/min] Maximum travel speed at 3000 rpm [mm/min]
5	3000
10	6000
16	9600
20	12000
25	15000
32	19200
40	24000
50	30000

**Tabelle di potenza e potenza equivalente**

Le tabelle di potenza sono riportate nelle pagine relative alle caratteristiche di ogni taglia di martinetto.

Scegliendo quelle relative alla grandezza selezionata sulla base del carico statico riportato nella tabella di pagina C8, C10 e C12 ed entrando in tabella con i valori del carico equivalente e della velocità di traslazione, si può ottenere il valore della potenza equivalente.

Se tale incrocio di valori cade nella zona colorata in rosso, significa che le condizioni applicative potrebbero causare fenomeni negativi quali surriscaldamento ed usure marcate; pertanto sarà necessario ridurre la velocità di traslazione o salire di grandezza.

La potenza equivalente non è la potenza richiesta dal singolo martinetto, a meno che i tre fattori correttivi  $f_t$ ,  $f_a$  e  $f_s$  non abbia-no valore unitario.

**Power and equivalent power tables**

*Power tables can be found on the characteristics pages for each screw jack size.*

*By choosing those for the selected size based on the static load given in the table on pages C8, C10 and C12 and entering the equivalent load and travel speed values in the table, the equivalent power value can be obtained.*

*If this intersection of values falls in the red area, it means that the application conditions could cause negative phenomena such as overheating and marked wear and tear; therefore, it will be necessary to reduce the travel speed or increase the size.*

*The equivalent power is not the power required by the individual screw jack, unless the three correction factors  $f_t$ ,  $f_a$  and  $f_s$  have unit values.*

**Formule di calcolo**

**Calculation formulas**

**Momento torcente**

A questo livello è possibile il calcolo della potenza richiesta dall'impianto.

La formula per questo conteggio è la seguente:

$$P = \frac{1}{1000} \cdot \frac{n \cdot C \cdot v}{6000 \cdot \eta_m \cdot \eta_c \cdot \eta_s}$$

con

- P = potenza necessaria [kW]
- n = numero di martinetti
- C = carico unitario [daN]
- $\eta_m$  = rendimento del martinetto [%]
- $\eta_c$  = rendimento della configurazione [%]
- $\eta_s$  = rendimento della struttura [%]
- v = velocità di traslazione [mm/min]

Nella quale la velocità di traslazione "v" viene definita dalla relazione

$$v = \frac{n_1 \cdot p}{i}$$

con p = passo della vite ed i = rapporto di riduzione del martinetto. La velocità  $n_1$  è la velocità angolare del motore che è differente dalla velocità angolare A della vite senza fine del martinetto. Nel caso in cui il motore sia connesso direttamente al martinetto senza interposizione di riduzioni o moltipliche, si avrà che  $n_1 = A$

A completamento del calcolo della potenza richiesta è necessario il calcolo del momento torcente che deve trasmettere l'albero motore.

$$M_{tm} = \frac{955 \cdot P}{n_1}$$

- P = potenza necessaria [kW]
- $n_1$  = numero di martinetti
- $M_{tm}$  = rendimento del martinetto [daNm]

A seconda dello schema di impianto applicato è necessario verificare che la vite senza fine sia in grado di resistere ad un eventuale sforzo torcente combinato. Pertanto la seguente tabella riporta i valori di torsione ammissibili dalle viti senza fine a seconda della loro grandezza espressi in [daNm].

**Torque**

At this level, it is possible to calculate the power required by the system.

The formula for this count is as follows:

with

- P = power required [kW]
- n = number of screw jacks
- C = unit load [daN]
- $\eta_m$  = screw jack efficiency [%]
- $\eta_c$  = configuration efficiency [%]
- $\eta_s$  = structure efficiency [%]
- v = travel speed [mm/min]

In which the translation velocity 'v' is defined by the relation

with p = screw pitch and i = screw jack reduction ratio. The speed  $n_1$  is the angular speed of the motor, which is different from the angular speed A of the screw jack's worm gear. If the motor is connected directly to the screw jack without the interposition of reductions or multiplications, it will be that  $n_1 = A$

To complete the calculation of the required power, it is necessary to calculate the torque to be transmitted by the drive shaft.

- P = power required [kW]
- $n_1$  = number of screw jacks
- $M_{tm}$  = screw jack efficiency [daNm]

Depending on the system design applied, it is necessary to check that the worm gear can withstand any combined torque stress. Therefore, the following table shows the permissible torque values of worm screws according to their size expressed in [daNm].



**Martinetti a vite trapezia**  
**Trapezoidal screw jacks**

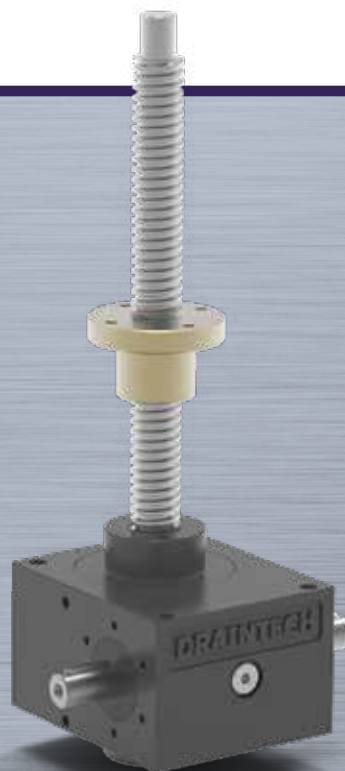

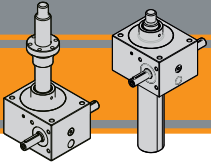

# DHT

Martinetti a vite trapezia  
*Trapezoidal screw jacks*

## DHT..T

Traslante  
*Translating*

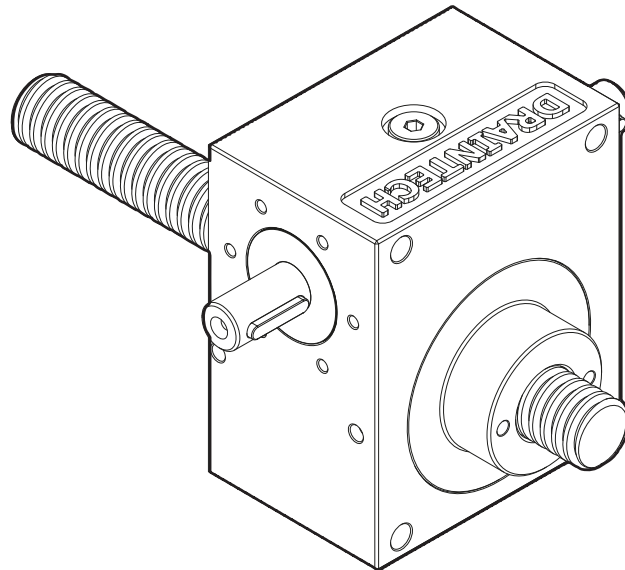

## DHT..R

Rotante  
*Rotating*

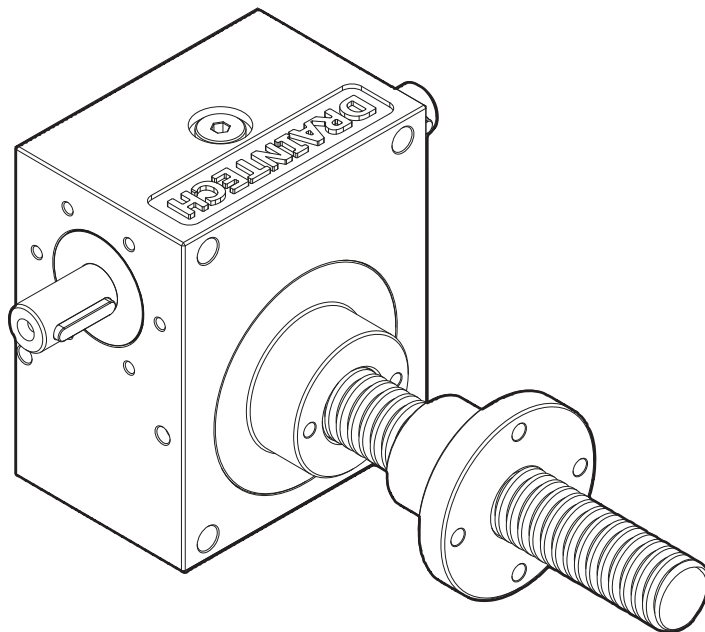

## DHT..

Motorizzato  
*Motorised*

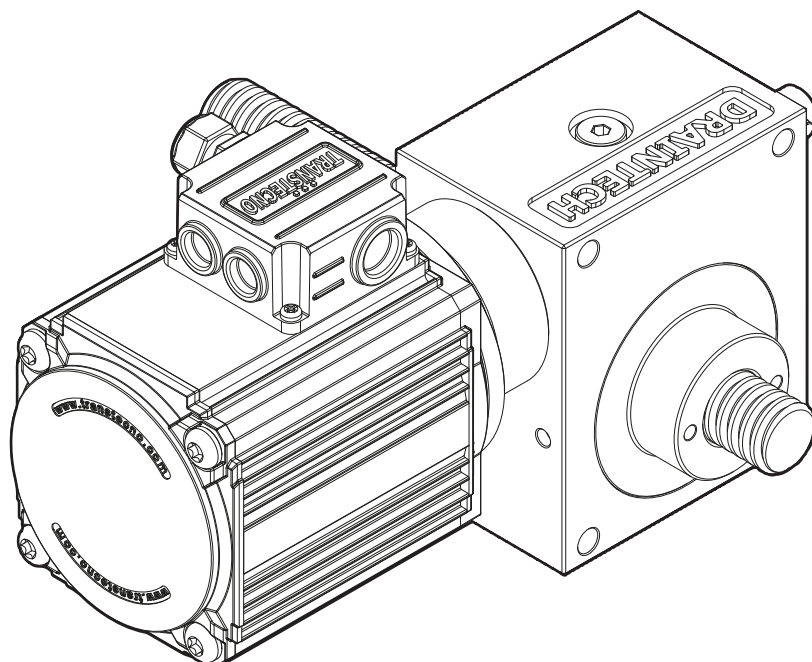

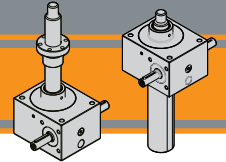

<b>Indice</b>	<b>Index</b>	<b>Pag. Page</b>
Caratteristiche tecniche	<i>Technical features</i>	<b>B4</b>
Designazione	<i>Designation</i>	<b>B5</b>
Forma costruttiva	<i>Constructive forms</i>	<b>B5</b>
Motori applicabili	<i>Applicable motors</i>	<b>B6</b>
Direzioni di rotazione e di movimento	<i>Rotation and movement directions</i>	<b>B8</b>
Sensi di rotazione sistemi multipli	<i>Multiple systems rotation directions</i>	<b>B8</b>
Schemi di montaggio	<i>Assembly diagrams</i>	<b>B9</b>
Schemi di montaggio - 2 martinetti	<i>Assembly diagrams - 2 screw jacks</i>	<b>B10</b>
Schemi di montaggio - 3 martinetti	<i>Assembly diagrams - 3 screw jacks</i>	<b>B11</b>
Schemi di montaggio - 4 martinetti	<i>Assembly diagrams - 4 screw jacks</i>	<b>B14</b>
Schemi di montaggio - 6 martinetti	<i>Assembly diagrams - 6 screw jacks</i>	<b>B15</b>
Dati tecnici - DHT183	<i>Technical data - DHT183</i>	<b>B18</b>
Dati tecnici - DHT184	<i>Technical data - DHT184</i>	<b>B20</b>
Dati tecnici - DHT204	<i>Technical data - DHT204</i>	<b>B22</b>
Dati tecnici - DHT306	<i>Technical data - DHT306</i>	<b>B24</b>
Dati tecnici - DHT407	<i>Technical data - DHT407</i>	<b>B26</b>
Dati tecnici - DHT559	<i>Technical data - DHT559</i>	<b>B28</b>
Dati tecnici - DHT609	<i>Technical data - DHT609</i>	<b>B30</b>
Dati tecnici - DHT7010	<i>Technical Data - DHT7010</i>	<b>B32</b>
Dati tecnici - DHT8010	<i>Technical data - DHT8010</i>	<b>B34</b>
Dati tecnici - DHT9010	<i>Technical data - DHT9010</i>	<b>B36</b>
Dati tecnici - DHT12014	<i>Technical data - DHT12014</i>	<b>B38</b>
Dati tecnici - DHT16016	<i>Technical data - DHT16016</i>	<b>B40</b>

Questa sezione annulla e sostituisce ogni precedente edizione o revisione. Qualora questa sezione non Vi sia giunta in distribuzione controllata, l'aggiornamento dei dati ivi contenuto non è assicurato. **In tal caso la versione più aggiornata è disponibile sul nostro sito internet [www.transtecno.com](http://www.transtecno.com)**

*This section replaces any previous edition and revision. If you obtained this catalogue other than through controlled distribution channels, the most up to date content is not guaranteed. In this case the latest version is available on our web site [www.transtecno.com](http://www.transtecno.com)*

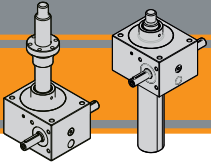

# DHT

## Martinetti a vite trapezia Trapezoidal screw jacks

### Caratteristiche generali

### General features

La nuova serie di martinetti di sollevamento meccanici a vite trapezia o con vite a ricircolo di sfere DRAINTECH, denominata DHT, è un prodotto la cui modularità è stata spinta all'estremo unitamente alle sue prestazioni.

Il know-how aziendale nella progettazione e costruzione di ruote dentate e viti senza fine ci ha permesso di ottimizzare i profili dell'ingranaggio ruota per vite senza fine e vite senza fine, massimizzando i rendimenti di ingranamento, la durata e la resistenza degli ingranaggi.

Il prodotto è rigorosamente made in Italy e l'impiego di materiali con alte prestazioni meccaniche quali :

- Carter: ghisa sferoidale con fosfatazione al manganese
- Viti senza fine: acciaio 18NiCrMo5 cementato e temprato con profili rettificati
- Corone: bronzo GB-CuSn12 DIN 17656
- Viti trapezoidali (TPN): C45 rullate

Lo posiziona ai più alti standard qualitativi disponibili sul mercato. L'accoppiamento con i motori elettrici è garantito grazie alla predisposizione con flange IEC B5 e B14.

*DRAINTECH's new series of mechanical trapezoidal screw jacks, called DHT, is a product whose modularity has been pushed to the extreme along with its performance.*

*The company's know-how in the design and construction of toothed gears and worm screws has enabled us to optimise the gear wheel profiles for worm screws, maximising gearing efficiency, durability and strength.*

*The product is strictly made in Italy and uses materials with high mechanical performance such as:*

- *Casing: spheroidal cast iron with manganese phosphating*
- *Worm screws: steel 18NiCrMo5 case-hardened and hardened with ground profiles*
- *Crowns: bronze GB-CuSn12 DIN 17656*
- *Trapezoidal screws (TPN): C45 rolled*

*It ranks at the highest quality standard available on the market. Coupling with electric motors is ensured by the set-up with IEC B5 and B14 flanges.*

Caratteristiche generali / General features													
Taglia Size		183	184	204	306	407	559	609	7010	8010	9010	12014	16016
Portata ammissibile Permissible flow rate	[daN]	500	500	1000	2500	5000	10000	15000	20000	25000	35000	60000	100000
Asta trapezia: diametro x passo Trapezoidal rod: diameter x pitch	[mm]	18x3	18x4	20x4	30x6	40x7	55x9	60x9	70x10	80x10	90x10	120x14	160x16
Corsa asta per giro ruota Rod stroke per wheel revolution	[mm]	veloce fast	1/5	1/5	1/5	1/5	1/5	1/5	1/5	1/5	1/5		
	normale normal	1/20	1/20	1/10	1/10	1/10	1/10	1/10	1/10	1/10	1/10	1/10	1/12
	lento slow			1/30	1/30	1/30	1/30	1/30	1/30	1/30	1/30	1/30	1/36
Corsa asta per giro ruota Rod stroke per wheel revolution	[mm]	3	4	4	6	7	9	9	10	10	10	14	16
Corsa asta per giro vite Rod stroke per screw rev	[mm]	veloce fast	0.6	0.8	0.8	1.2	1.4	1.8	1.8	2.0	2.0	2.0	
	normale normal		0.2	0.4	0.6	0.7	0.9	0.9	1.0	1.0	1.0	1.4	1.33
	lento slow			0.13	0.2	0.23	0.3	0.3	0.33	0.33	0.33	0.47	0.44
Efficiency	[%]	veloce fast	25	25	25	24	22	21	20.5	20	19	19	
	normale normal		23	23	22	20	20	20	19.5	19	18.5	18.5	18
	lento slow			20	20	19	18	17	16.5	16	16	12	9
Peso vite trapezia per 100mm Trapezoidal screw weight per 100 mm	[kg]	0.16	0.16	0.22	0.5	0.9	1.7	2.0	2.8	345	4.0	8.1	14
Peso martinetto (vite esclusa) Weight of screw jack (excluding screw)	[kg]	2	2	4	10	18	34	34	56	62	62	180	555

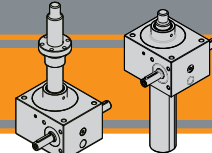

MARTINETTI DHT / DHT SCREW JACKS

DHT	306	T	400	105	TP	AB	FC	56B14
Tipo Type	Taglia Size	Versione martinetto Screw jack version	Corsa Stroke	Rapporto di riduzione Reduction ratio	Terminale Terminal	Forma costruttiva Constructive form	Accessori Accessories	Grandezza flangia motore Motor flange size
DHT	183 184 204 306 407 559 609 7010 8010 9010 12014 16016	T Traslante con vite trapezia Translating with trapezoidal screw  R Rotante con vite trapezia Rotating with trapezoidal screw  VT * Traslante con vite a ricircolo di sfere Translating with ball screw  VR * Rotante con vite a ricircolo di sfere Rotating with ball screw		R105 1:05 R110 1:10 R112 1:12 R120 1:20 R130 1:30 R136 1:36	TP TS TL TF TO TFC TOC TMR TLR TC ST	AD AS AB FSA FDA FD FS	PO PR NG PRO AS PE AR ARD FCO PL CSU FCP FC RGT RGR RGR BIG	

\* a richiesta / on demand

Forma costruttiva

Constructive forms

Per definizione la forma costruttiva è identificata osservando il martinetto rivolto verso l'osservatore. In questo modo sono identificabili le posizioni a destra o a sinistra sia degli alberi sia delle flange

By definition, the construction form is identified by observing the screw jack with the end facing the observer. In this way, the left or right positions of both shafts and flanges can be identified

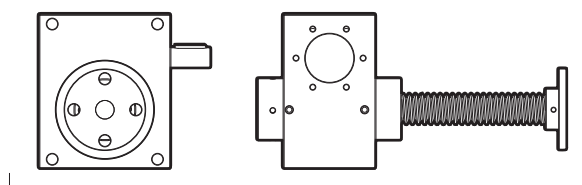

AD  
Albero a destra / Right-hand shaft

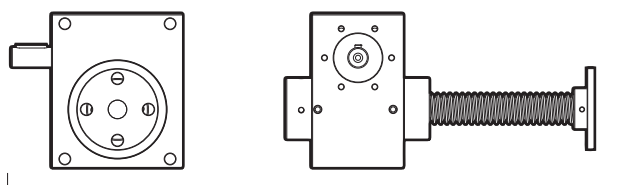

AS  
Albero a sinistra / Left-hand shaft

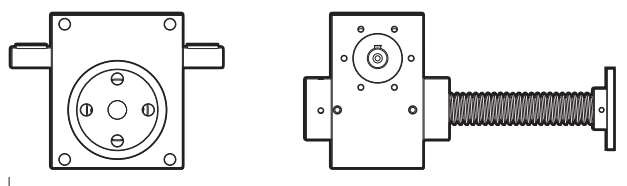

AB  
Albero bisporgente / Double ended shaft

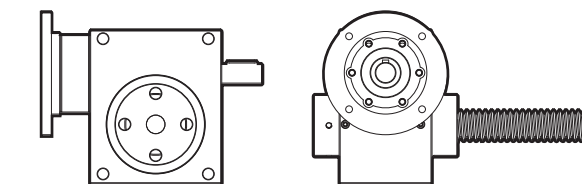

FSA  
Flangia a sinistra + albero / Left flange + shaft

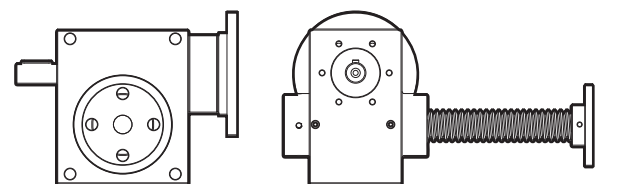

FDA  
Flangia a destra + albero / Right flange + shaft

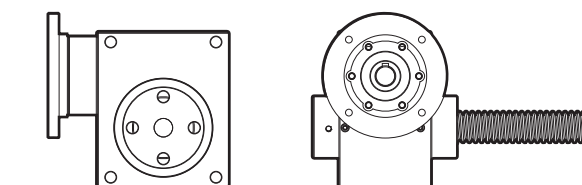

FS  
Flangia a sinistra / Left flange

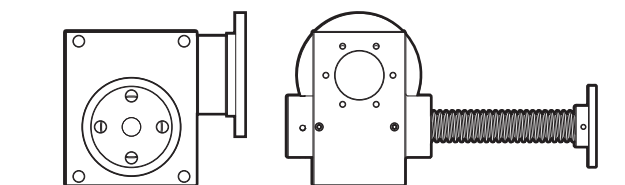

FD  
Flangia a destra / Right flange

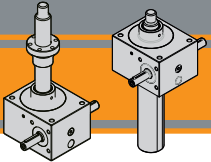

# DHT

## Martinetti a vite trapezia Trapezoidal screw jacks

### Motori applicabili

### Applicable motors

Tutti i nostri martinetti sono fornibili nella loro versione motorizzata. Abbiamo pertanto reso disponibile una vasta gamma di predisposizioni attacco motore corrispondenti agli standard IEC fino alla 132 in B5 e B14.

All our screw jacks are available in their motorised version. We have therefore made available a wide range of motor connection arrangements corresponding to IEC standards up to 132 in B5 and B14.

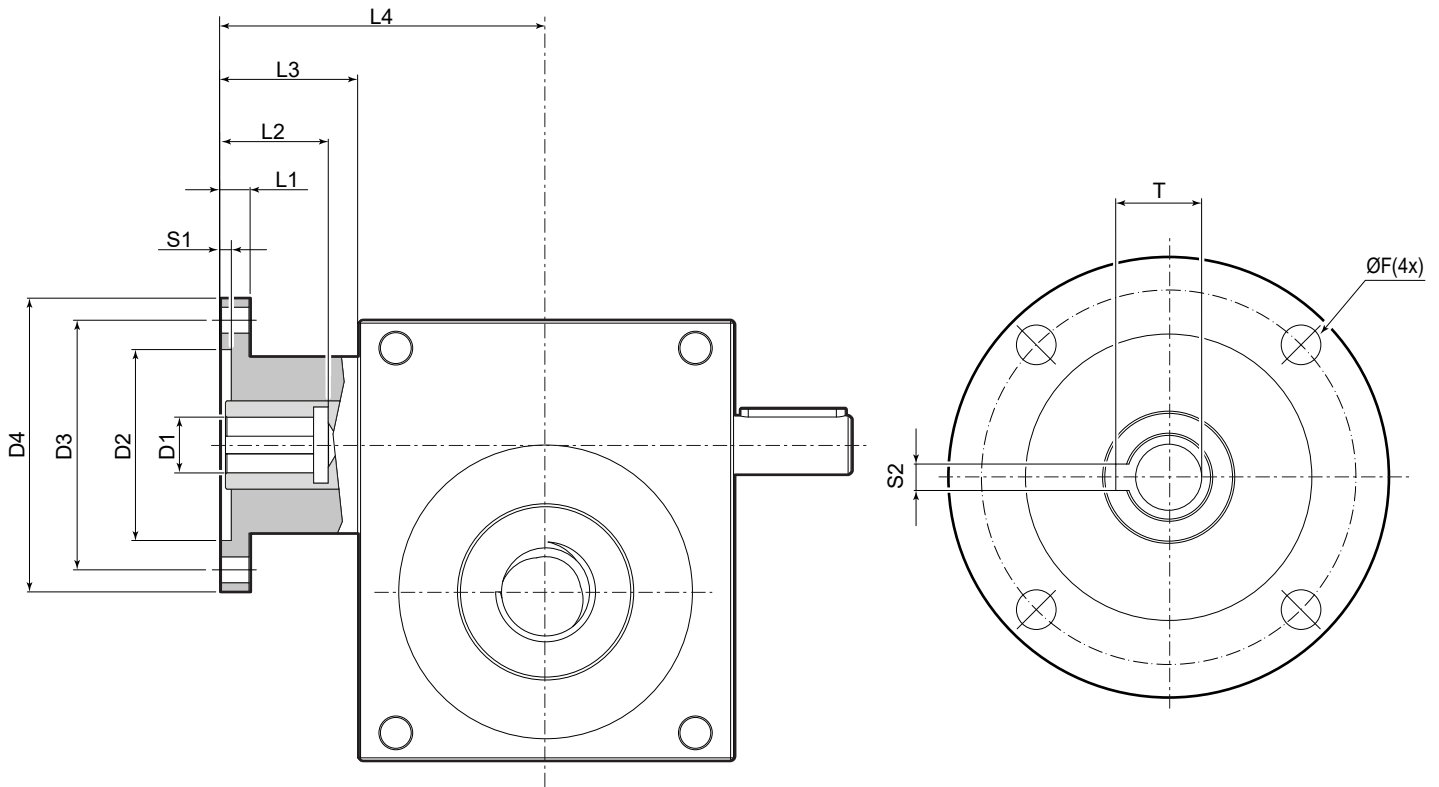

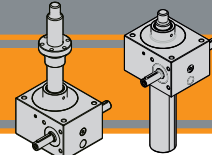

Motori applicabili

Applicable motors

Flange motore IEC / IEC motor flanges														
Taglia Size	Flangia Flange	D1 H7	D2 H7	D3	D4	ØF	L3	L1	L2	L4	S1	S2	T	
183/184	56 B5	9	80	100	120	6.6	70.5	9,5	38.5	106.5	6	3	10.4	
	63 B5	11	95	115	140	9.0	70.5	9,5	42.5	106.5	6	4	12.8	
	63 B14	11	60	75	90	5.5	70.5	6	42.5	106.5	6	4	12.8	
204	56 B5	9	80	100	120	6.6	43.0	9,5	40	92	6	3	10.4	
	63 B5	11	95	115	140	9.0	43.0	9,5	40	92	6	4	12.8	
	63 B14	11	60	75	90	5.5	43.0	6.0	40	92	6	4	12.8	
	71 B5	14	110	130	160	9.0	43.0	9,5	40	92	6	5	16.3	
	71 B14	14	70	85	105	8.0	43.0	9,5	40	92	6	5	16.3	
306	63 B5	11	95	115	140	9.0	48.5	10.0	45	112.5	4.0	4	12.8	
	63 B14	11	60	75	90	5.5	48.5	6.0	45	112.5	6.0	4	12.8	
	71 B5	14	110	130	160	9.0	48.5	10.0	45	112.5	4.0	5	16.3	
	71 B14	14	70	85	105	8.0	48.5	9.0	45	112.5	4.0	5	16.3	
	80 B5	19	130	165	200	11.0	48.5	10.0	45	112.5	4.0	6	21.8	
	80 B14	19	80	100	120	6.6	48.5	10.0	45	112.5	4.0	6	21.8	
	90B5	24	130	165	200	11.0	48.5	10.0	45	112.5	4.0	6	21.8	
407	71 B5	14	110	130	160	9.0	66.5	11.0	58	149	4.5	5	16.3	
	71 B14	14	70	85	105	8.0	66.5	9.0	45	150.5	4.0	5	16.3	
	80 B5	19	130	165	200	11.0	66.5	11.0	58	149	4.5	6	21.8	
	80 B14	19	80	100	120	6.6	66.5	11.0	58	149	4.5	6	21.8	
	90 B5	24	130	165	200	11.0	66.5	11.0	58	149	4.5	8	27.3	
	90 B14	24	95	115	140	9.0	66.5	11.0	58	149	4.5	8	27.3	
	100-112 B5	28	180	215	250	13.5	66.5	11.0	58	149	4.5	8	31.3	
100-112 B14	28	110	130	160	9.0	66.5	11.0	58	149	4.5	8	31.3		
559	71 B5	14	110	130	160	9.0	66.5	11.0	58	151.5	4.5	5	16.3	
	71 B14	14	70	85	105	8.0	66.5	9.0	45	153.0	4.0	5	16.3	
	80 B5	19	130	165	200	11.0	66.5	11.0	58	151.5	4.5	6	21.8	
	80 B14	19	80	100	120	6.6	66.5	11.0	58	151.5	4.5	6	21.8	
	90 B5	24	130	165	200	11.0	66.5	11.0	58	151.5	4.5	8	27.3	
	90 B14	24	95	115	140	9.0	66.5	11.0	58	151.5	4.5	8	27.3	
	100-112 B5	28	180	215	250	13.5	66.5	11.0	58	151.5	4.5	8	31.3	
100-112 B14	28	110	130	160	9.0	66.5	11.0	58	151.5	4.5	8	31.3		
609	71 B5	14	110	130	160	9.0	66.5	11.0	58	151.5	4.5	5	16.3	
	71 B14	14	70	85	105	8.0	66.5	9.0	45	153.0	4.0	5	16.3	
	80 B5	19	130	165	200	11.0	66.5	11.0	58	151.5	4.5	6	21.8	
	80 B14	19	80	100	120	7.0	66.5	11.0	58	151.5	4.5	6	21.8	
	90 B5	24	130	165	200	11.0	66.5	11.0	58	151.5	4.5	8	27.3	
	90 B14	24	95	115	140	9.0	66.5	11.0	58	151.5	4.5	8	27.3	
	100-112 B5	28	180	215	250	13.5	66.5	11.0	58	151.5	4.5	8	31.3	
100-112 B14	28	110	130	160	9.0	66.5	11.0	58	151.5	4.5	8	31.3		
7010	90 B5	24	130	165	200	11.0	83.0	11.0	75	198	4.5	8	31.3	
	100-112 B5	28	180	215	250	13.5	83.0	13.5	75	198	6.5	8	31.3	
	100-112 B14	28	110	130	160	9.0	83.0	13.5	75	198	6.5	8	31.3	
	132 B5	Contattare il nostro Ufficio Tecnico / Contact our Technical Department												
8010	132 B14	38	130	165	200	11.0	83.0	11.0	85.5	198	4.5	10	41.3	
	90 B5	24	130	165	200	11.0	83.0	11.0	75	198	4.5	8	31.3	
	100-112 B5	28	180	215	250	13.5	83.0	13.5	75	198	6.5	8	31.3	
	100-112 B14	28	110	130	160	9.0	83.0	13.5	75	198	6.5	8	31.3	
9010	132 B5	Contattare il nostro Ufficio Tecnico / Contact our Technical Department												
	132 B14	38	130	165	200	11.0	83.0	11.0	85.5	198	4.5	10	41.3	
	90 B5	24	130	165	200	11.0	83.0	11.0	75	198	4.5	8	31.3	
	100-112 B5	28	180	215	250	13.5	83.0	13.5	75	198	6.5	8	31.3	
12014 16016	100-112 B14	28	110	130	160	9.0	83.0	13.5	75	198	6.5	8	31.3	
	132 B5	Contattare il nostro Ufficio Tecnico / Contact our Technical Department												
12014 16016	132 B14	38	130	165	200	11.0	83.0	11.0	85.5	198	4.5	10	41.3	
	Contattare il nostro Ufficio Tecnico / Contact our Technical Department													

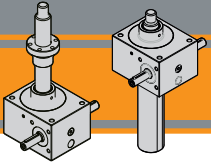

### Direzione di rotazione e movimento

### Direction of rotation and movement

I martinetti standard vengono forniti con vite trapezia destra a cui corrispondono i sensi di rotazione e di movimento riportati nelle figure sottostanti.

Standard screw screw jacks are supplied with a right-hand trapezoidal screw to which correspond to the directions of rotation and movement shown in the figures below.

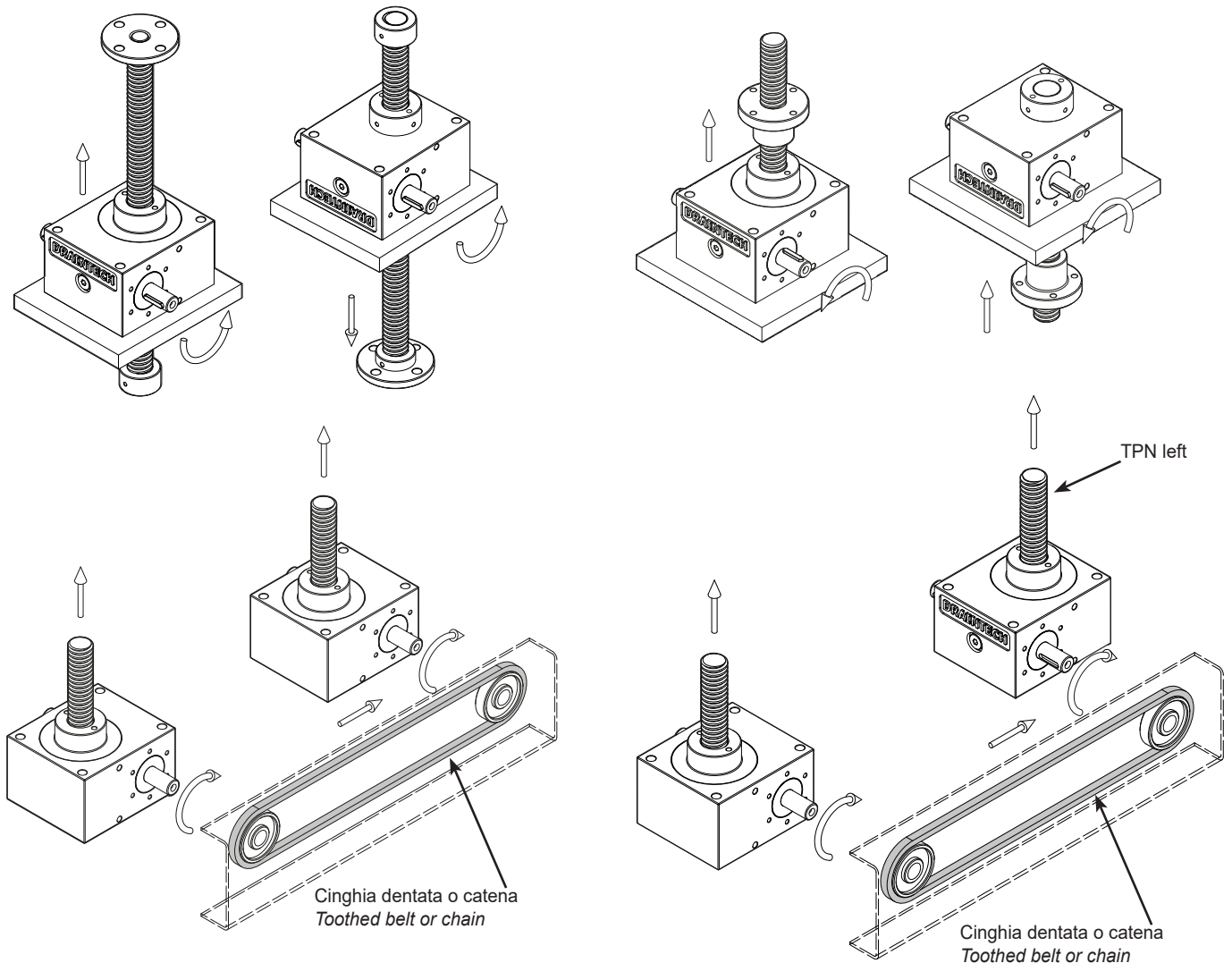

### Sensi di rotazione sistemi multipli

### Multiple systems rotation directions

Nella realizzazione di un sistema a più martinetti, occorre fare attenzione alla direzione di rotazione dell'impianto. Si consiglia di consultare i nostri schemi di montaggio standard.

When constructing a multiple screw jack system, attention must be paid to the direction of rotation of the system. Please refer to our standard assembly diagrams.

In caso i rinvii angolari a 3 vie, la direzione di rotazione può essere modificata grazie alla semplice rotazione del rinvio stesso.

In the case of 3-way right-angle bevel gearboxes, the direction of rotation can be changed by simply turning the gearbox.

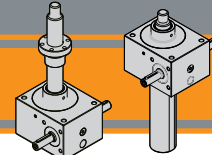

Schemi di montaggio

Assembly diagrams

Legenda  
Legend

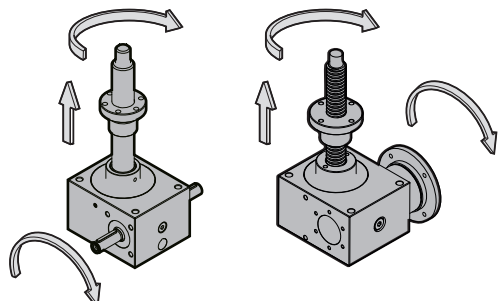

Martinetto  
Screwjack

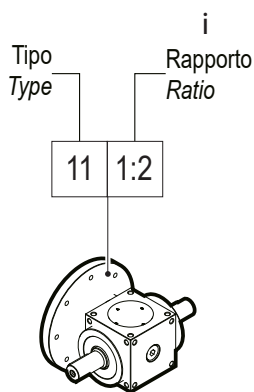

Rinvio Angolare (Consultare il catalogo serie QB)  
Right-angle bevel gearbox (Consult the QB series catalog)

- 1:1  
 1:1,5  
 1:2  
 1:3  
 1:4
- Rapporti Disponibili  
Available Ratios

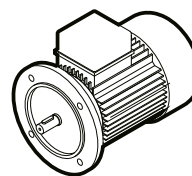

Motore  
Motor

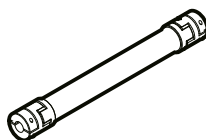

Albero di trasmissione  
Transmission Shaft



Giunto  
Coupling

AB AS AD FSA FDA FS FD

ORIENTAMENTO FLANGIA MOTORE E ALBERI (vedi pag. B6)  
DRIVE FLANGE AND SHAFTS ORIENTATION (see page B6)

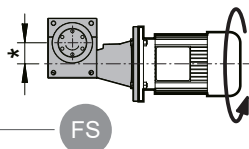

NOTA: La quota "\*" varia in funzione della taglia del martinetto / rinvio

NOTE: Dimension "\*" varies according to the size of the screw jack/right angle bevel gearbox

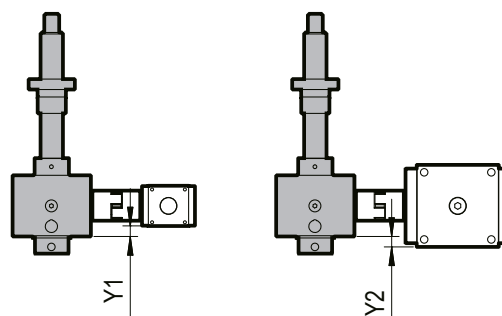

NOTA: Le quote Y1 e Y2 di altezza tra martinetto e rinvio possono avere differenti misure in funzione dei modelli di rinvio utilizzato.

NOTE: The amounts Y1 and Y2 being the height of the screw jack and right-angle bevel gearbox may have different measurements depending on the right-angle bevel gearbox models used.

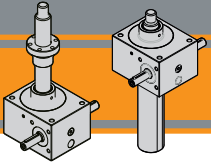

# DHT

## Martinetti a vite trapezia Trapezoidal screw jacks

### Schemi di montaggio 2 martinetti

### Assembly diagrams 2 screw jacks

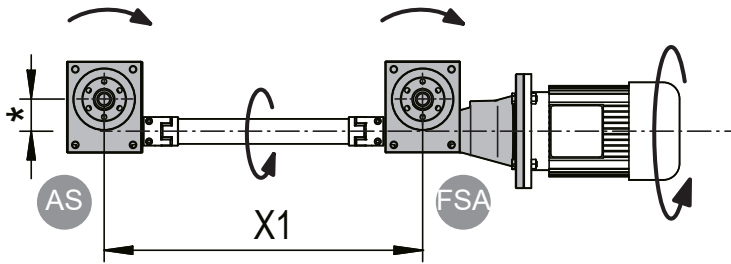

		2.A
Rendimento del sistema System efficiency	$\eta_c$	0.95
Versione martinetto Screw jack version		Qty
	AS	1
	FSA	1

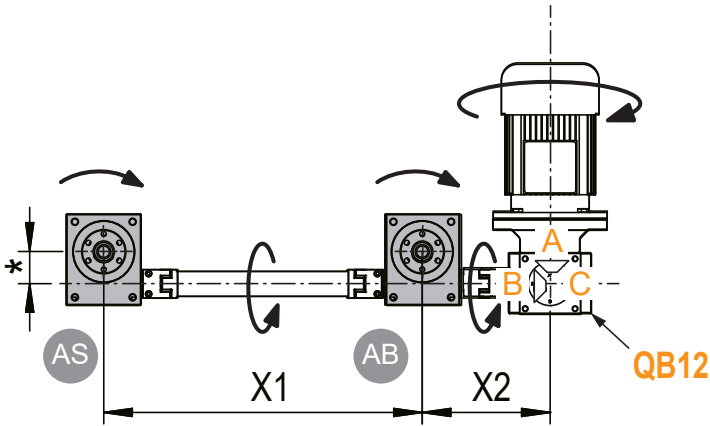

		2.B
Rendimento del sistema System efficiency	$\eta_c$	0.90
Versione martinetto Screw jack version		Qty
	AB	1
	AS	1
Rinvio angolare Right-angle bevel gearbox	i	Qty
	QB12	All 1

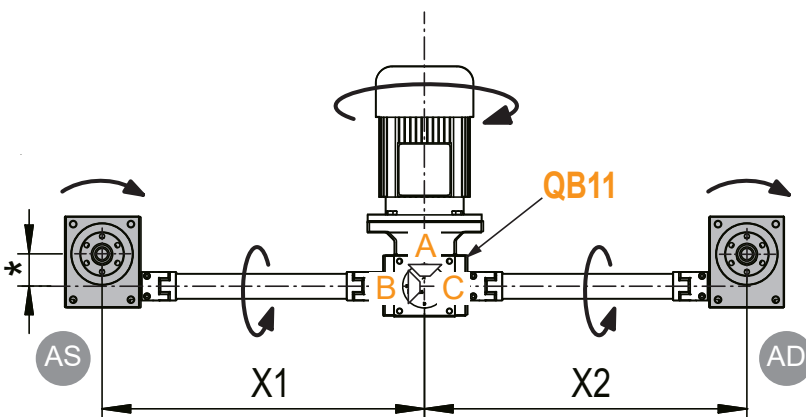

		2.C
Rendimento del sistema System efficiency	$\eta_c$	0.90
Versione martinetto Screw jack version		Qty
	AS	1
	AD	1
Rinvio angolare Right-angle bevel gearbox	i	Qty
	QB11	All 1

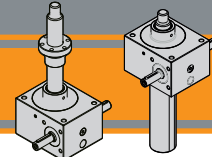

Schemi di montaggio  
3 martinetti

Assembly diagrams  
3 screw jacks

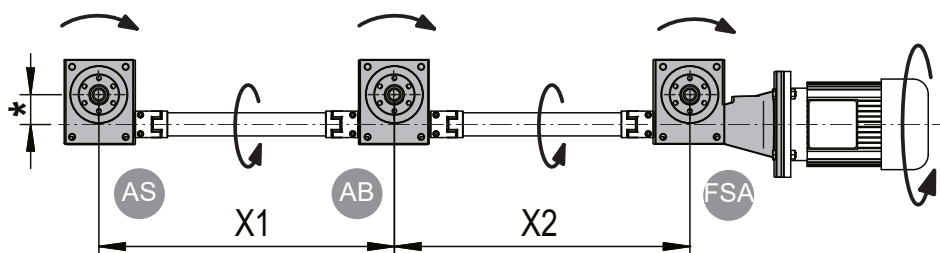

		3.A
Rendimento del sistema System efficiency	$\eta_c$	0.90
Versione martinetto Screw jack version		Qty
AB		1
AS		1
FSA		1

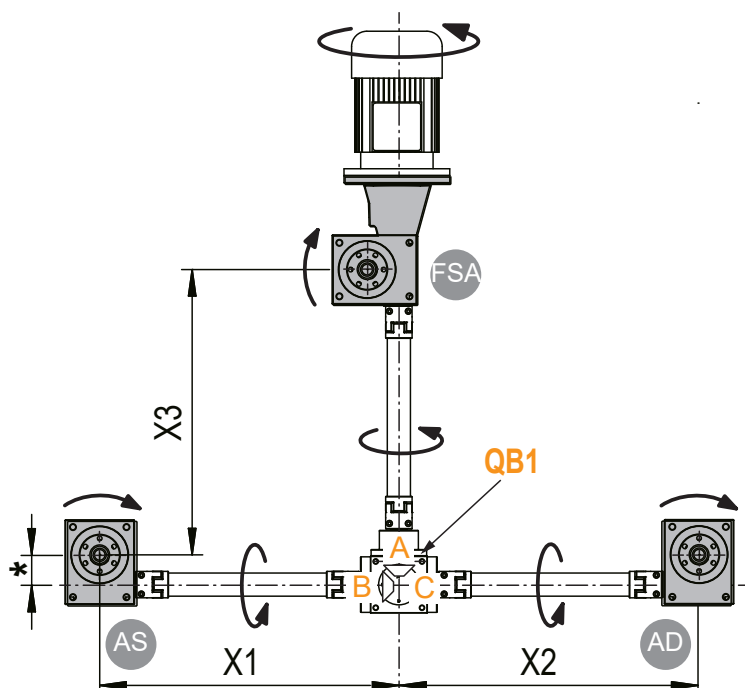

		3.B
Rendimento del sistema System efficiency	$\eta_c$	0.87
Versione martinetto Screw jack version		Qty
AS		1
AD		1
FSA		1
Rinvio angolare Right-angle bevel gearbox	i	Qty
QB1	All	1

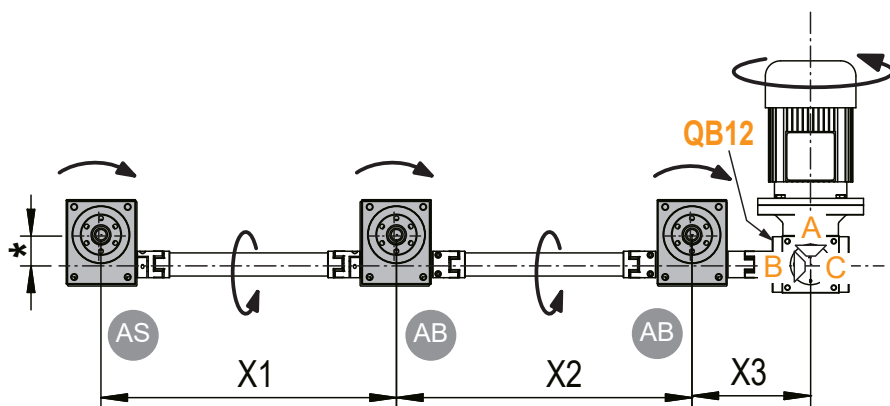

		3.C
Rendimento del sistema System efficiency	$\eta_c$	0.87
Versione martinetto Screw jack version		Qty
AB		2
AS		1
Rinvio angolare Right-angle bevel gearbox	i	Qty
QB12	All	1

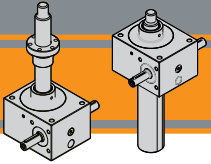

# DHT

## Martinetti a vite trapezia Trapezoidal screw jacks

### Schema di montaggio 3 martinetti

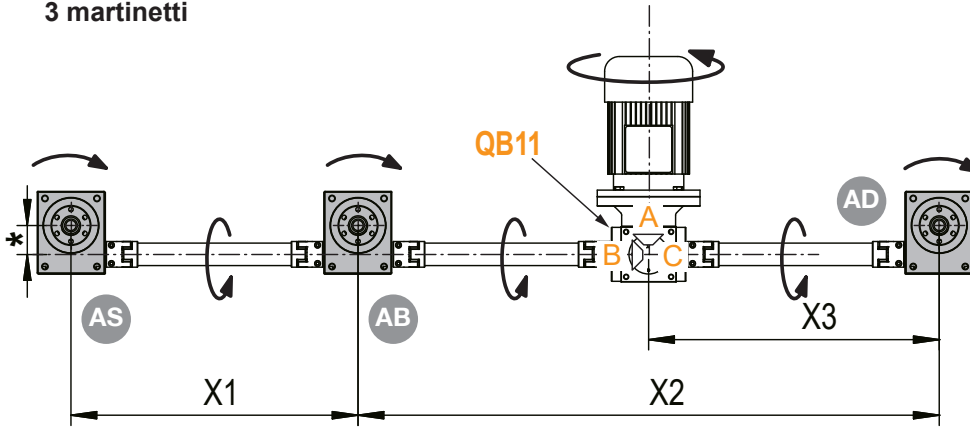

### Assembly diagrams 3 screw jacks

		3.D
Rendimento del sistema System efficiency	$\eta_c$	0.87
Versione martinetto Screw jack version		Qty
	AB	1
	AS	1
	AD	1
Rinvio angolare Right-angle bevel gearbox		i Qty
	QB11	All 1

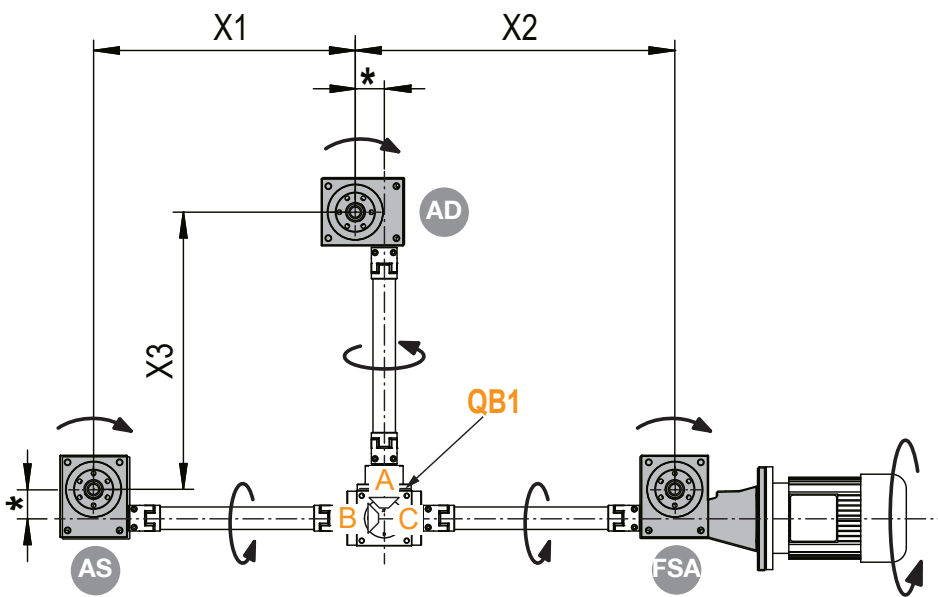

		3.E
Rendimento del sistema System efficiency	$\eta_c$	0.87
Versione martinetto Screw jack version		Qty
	AS	1
	AD	1
	FSA	1
Rinvio angolare Right-angle bevel gearbox		i Qty
	QB1	1:1 1

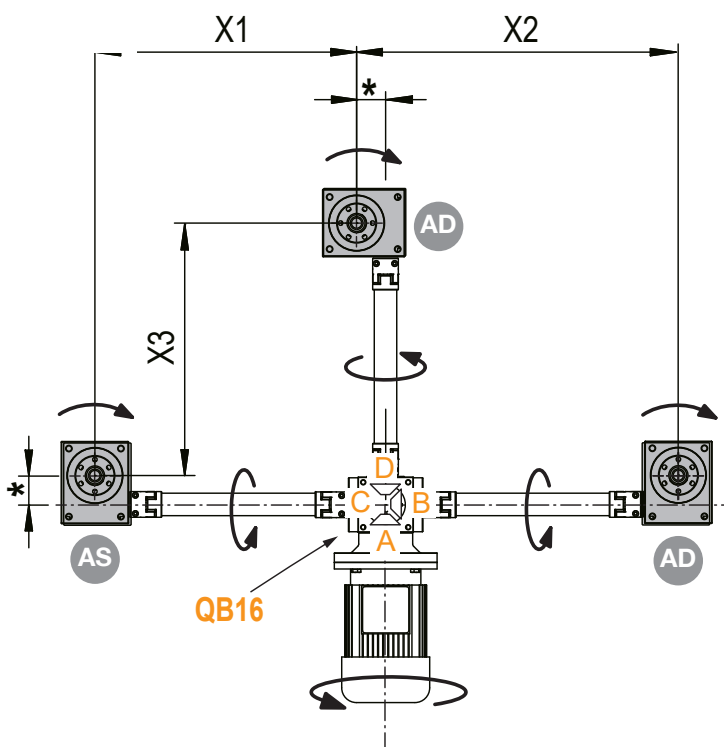

		3.F
Rendimento del sistema System efficiency	$\eta_c$	0.87
Versione martinetto Screw jack version		Qty
	AS	1
	AD	2
Rinvio angolare Right-angle bevel gearbox		i Qty
	QB16	1:1 1

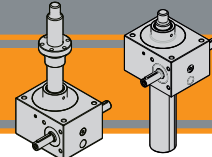

Schemi di montaggio  
3 martinetti

Assembly diagrams  
3 screw jacks

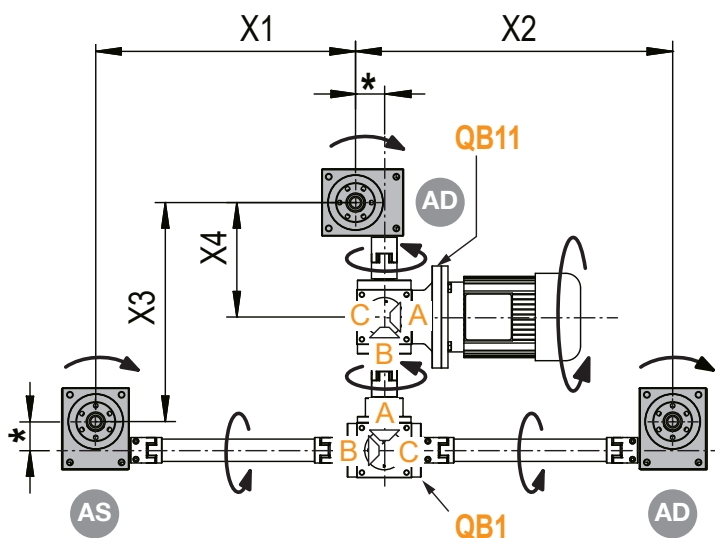

<b>3.G</b>		
Rendimento del sistema System efficiency	$\eta_c$	0.87
Versione martinetto Screw jack version		
	AS	1
	AD	2
Rinvio angolare Right-angle bevel gearbox		
	QB11	All 1
	QB1	1:1 1

Schemi di montaggio  
4 martinetti

Assembly diagrams  
4 screw jacks

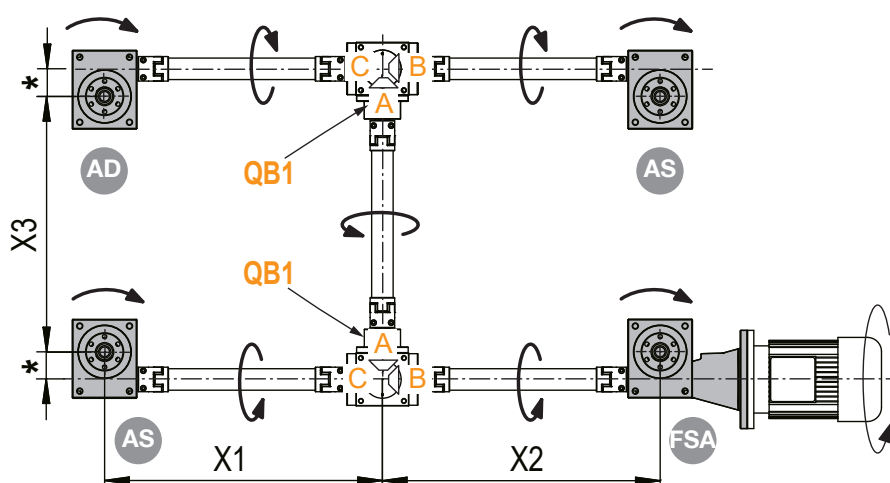

<b>4.A</b>		
Rendimento del sistema System efficiency	$\eta_c$	0.80
Versione martinetto Screw jack version		
	AS	2
	AD	1
	FSA	1
Rinvio angolare Right-angle bevel gearbox		
	QB1	1:1 2

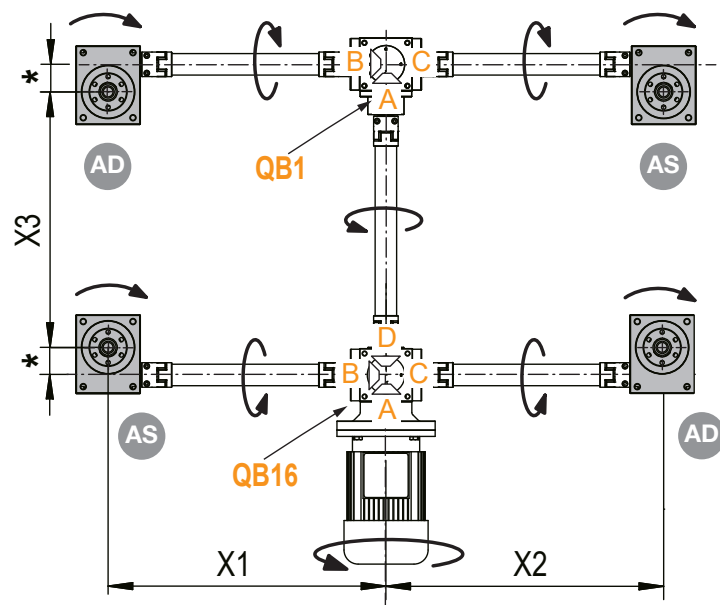

<b>4.B</b>		
Rendimento del sistema System efficiency	$\eta_c$	0.80
Versione martinetto Screw jack version		
	AS	2
	AD	2
Rinvio angolare Right-angle bevel gearbox		
	QB1	All 1
	QB16	All 1

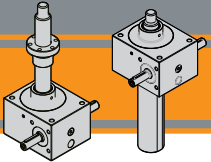

# DHT

## Martinetti a vite trapezia Trapezoidal screw jacks

### Schemi di montaggio 4 martinetti

### Assembly diagrams 4 screw jacks

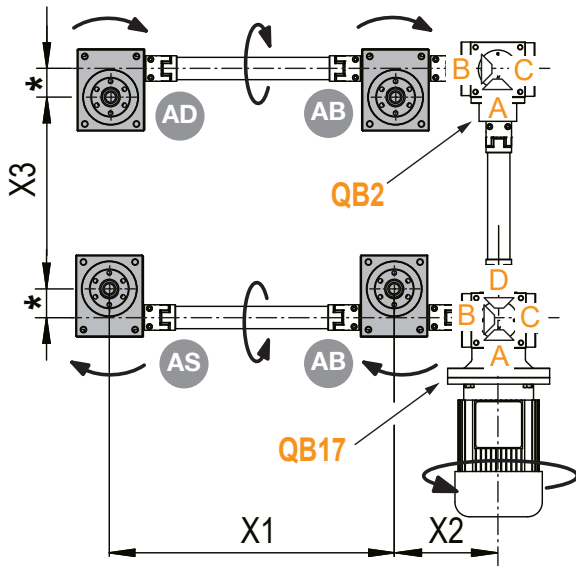

4.C		
Rendimento del sistema System efficiency	$\eta_c$	0.80
Versione martinetto Screw jack version		Qty
AB		1
AS		1
AD		1
Rinvio angolare Right-angle bevel gearbox		
QB17		All 1
QB2		All 1

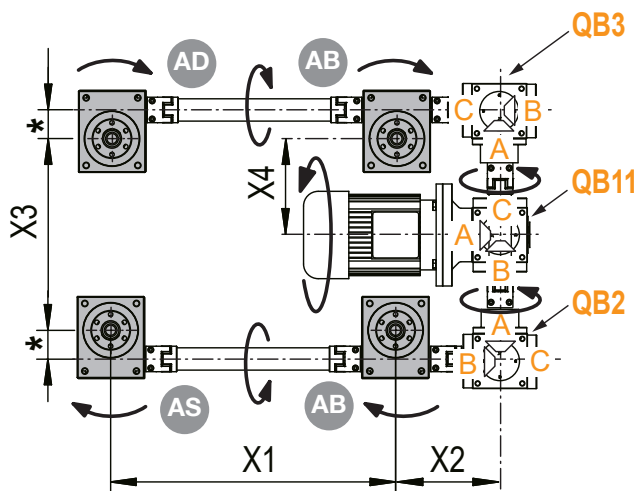

4.D		
Rendimento del sistema System efficiency	$\eta_c$	0.76
Versione martinetto Screw jack version		Qty
AB		2
AS		1
AD		1
Rinvio angolare Right-angle bevel gearbox		
QB11		All 1
QB2		All 1
QB3		All 1

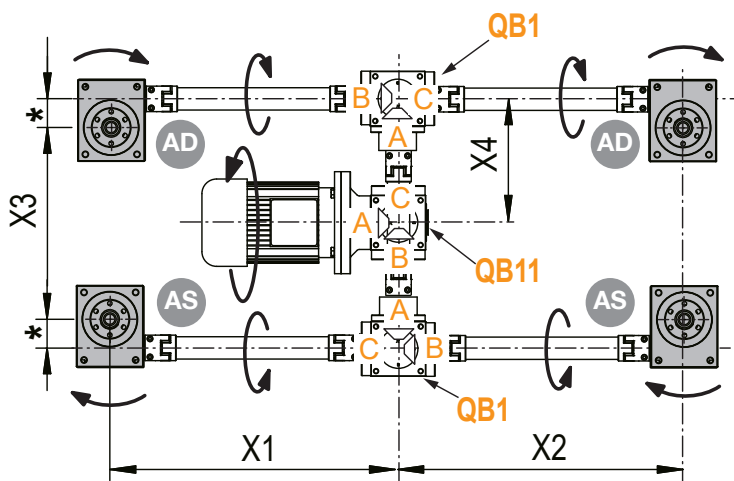

4.E		
Rendimento del sistema System efficiency	$\eta_c$	0.76
Versione martinetto Screw jack version		Qty
AS		2
AD		2
Rinvio angolare Right-angle bevel gearbox		
QB11		All 1
QB1		All 1

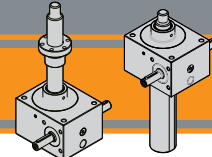

Schemi di montaggio  
6 martinetti

Assembly diagrams  
6 screw jacks

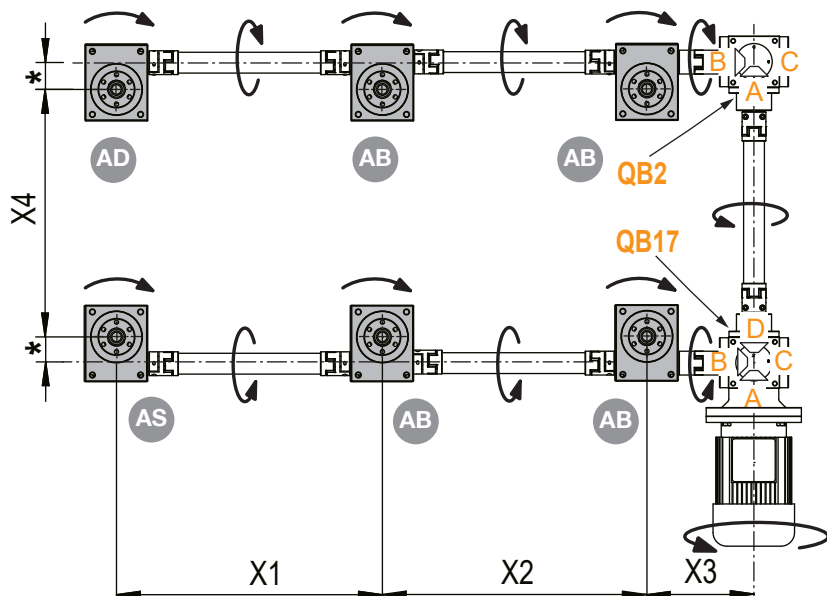
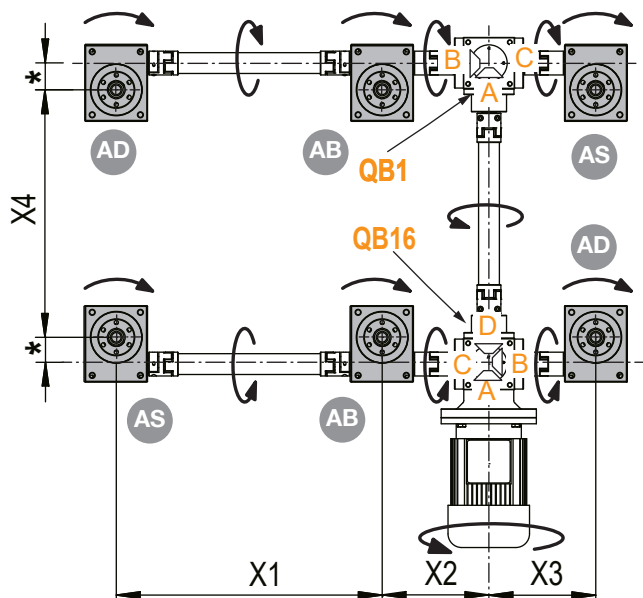
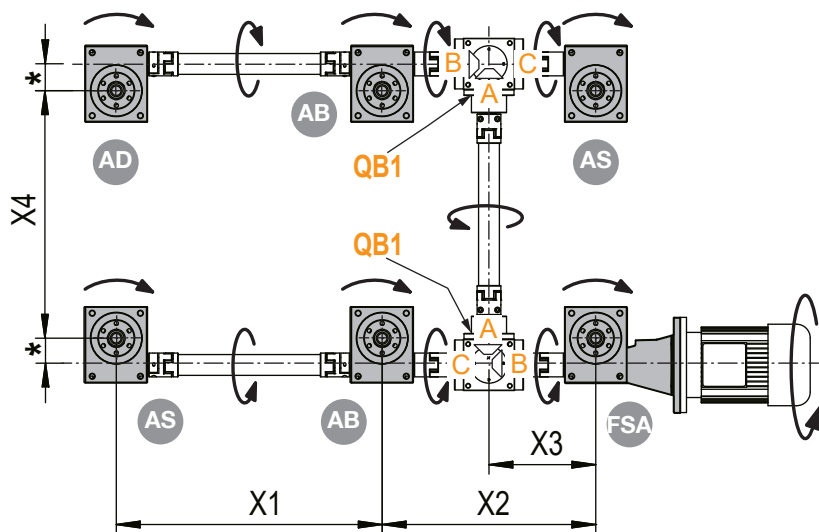

		6.A
Rendimento del sistema System efficiency	$\eta_c$	0.74
Versione martinetto Screw jack version		Qty
	AB	2
	AS	2
	AD	1
	FSA	1
Rinvio angolare Right-angle bevel gearbox		i Qty
	QB1	1:1 2

		6.B
Rendimento del sistema System efficiency	$\eta_c$	0.74
Versione martinetto Screw jack version		Qty
	AB	2
	AS	2
	AD	2
Rinvio angolare Right-angle bevel gearbox		i Qty
	QB16	All 1
	QB1	All 1

		6.C
Rendimento del sistema System efficiency	$\eta_c$	0.74
Versione martinetto Screw jack version		Qty
	AB	4
	AS	1
	AD	1
Rinvio angolare Right-angle bevel gearbox		i Qty
	QB17	All 1
	QB2	All 1

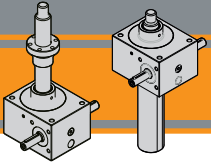

### Schemi di montaggio 6 martinetti

### Assembly diagrams 6 screw jacks

6.D  $\eta_c = 0,71$

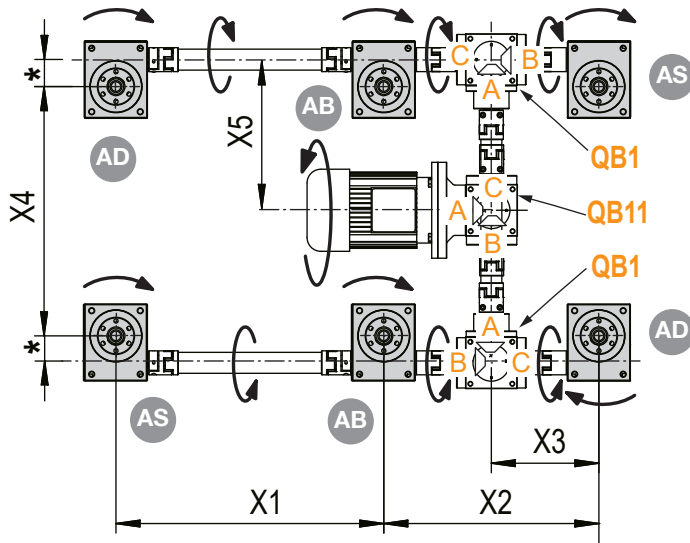

			6.D
Rendimento del sistema System efficiency	$\eta_c$		0.71
Versione martinetto Screw jack version			Qty
	AB		2
	AS		2
	AD		2
Rinvio angolare Right-angle bevel gearbox			i Qty
	QB11	All	1
	QB1	All	2

6.E  $\eta_c = 0,71$

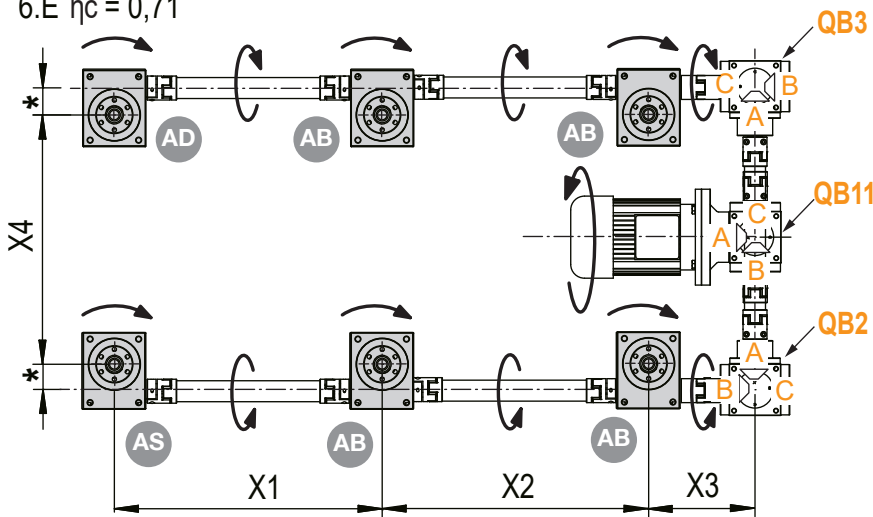

			6.E
Rendimento del sistema System efficiency	$\eta_c$		0.71
Versione martinetto Screw jack version			Qty
	AB		4
	AS		1
	AD		1
Rinvio angolare Right-angle bevel gearbox			i Qty
	QB11	All	1
	QB2	All	1
	QB1	All	1

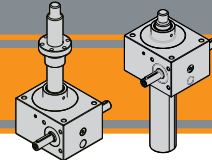

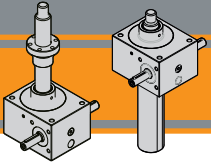

# DHT

## Martinetti a vite trapezia Trapezoidal screw jacks

Dati tecnici

Technical data

### DHT 183

Carico / Load [daN]			500		300		100		50	
Rapporto di riduzione Reduction ratio	Velocità di sollevamento Lifting speed [mm/min]	Giri in entrata Input revs [rpm]	P <sub>n</sub> [Kw]	M <sub>t</sub> [daNm]	P <sub>n</sub> [Kw]	M <sub>t</sub> [daNm]	P <sub>n</sub> [Kw]	M <sub>t</sub> [daNm]	P <sub>n</sub> [Kw]	M <sub>t</sub> [daNm]
5:1	900	1500	0.39	0.25	0.24	0.15	0.08	0.05	0.07	0.04
	600	1000	0.26	0.25	0.16	0.15	0.07	0.05	0.07	0.04
	450	750	0.20	0.25	0.12	0.15	0.07	0.05	0.07	0.04
	30	50	0.07	0.25	0.07	0.15	0.07	0.05	0.07	0.04

Carico / Load [daN]			500		300		100		50	
Rapporto di riduzione Reduction ratio	Velocità di sollevamento Lifting speed [mm/min]	Giri in entrata Input revs [rpm]	P <sub>n</sub> [Kw]	M <sub>t</sub> [daNm]	P <sub>n</sub> [Kw]	M <sub>t</sub> [daNm]	P <sub>n</sub> [Kw]	M <sub>t</sub> [daNm]	P <sub>n</sub> [Kw]	M <sub>t</sub> [daNm]
20:1	225	1500	0.08	0.06	0.07	0.04	0.07	0.04	0.07	0.04
	150	1000	0.07	0.06	0.07	0.04	0.07	0.04	0.07	0.04
	112.5	750	0.07	0.06	0.07	0.04	0.07	0.04	0.07	0.04
	7.5	50	0.07	0.06	0.07	0.04	0.07	0.04	0.07	0.04

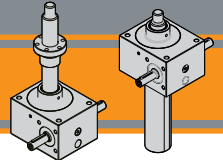

DHT 183

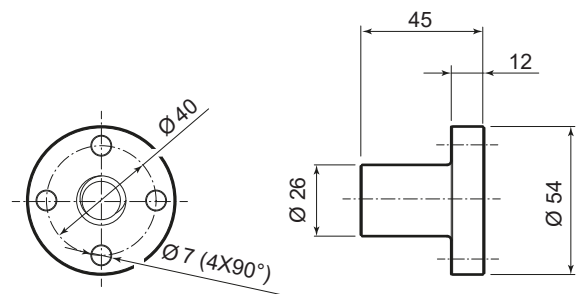
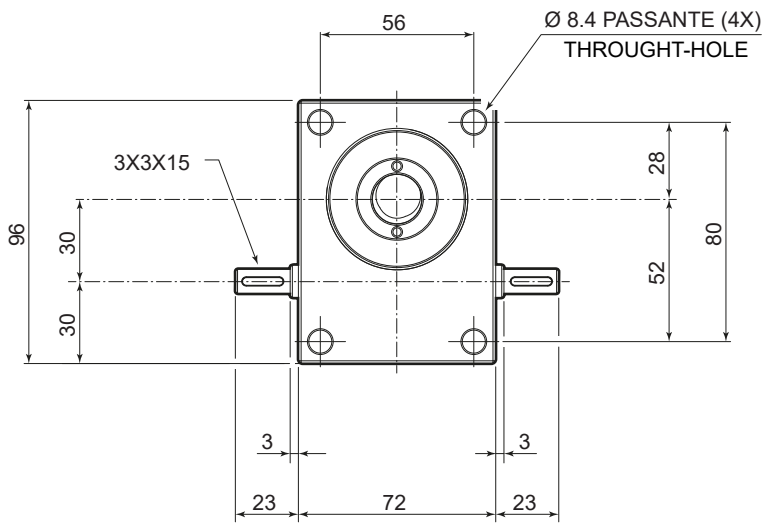
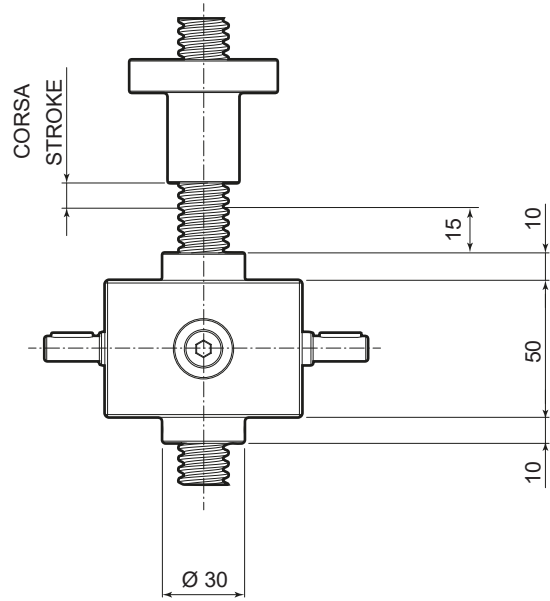
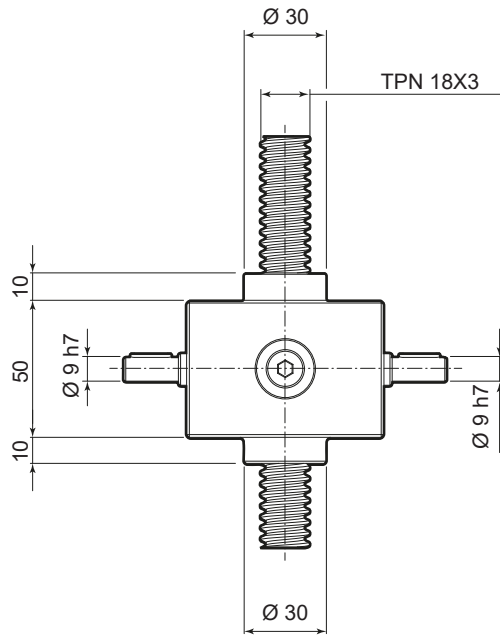

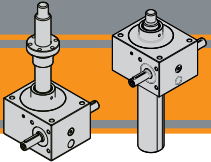

# DHT

## Martinetti a vite trapezia Trapezoidal screw jacks

Dati tecnici

Technical data

### DHT 184

Carico / Load [daN]			500		300		100		50	
Rapporto di riduzione Reduction ratio	Velocità di sollevamento Lifting speed [mm/min]	Giri in entrata Input revs [rpm]	P <sub>n</sub> [Kw]	M <sub>t</sub> [daNm]	P <sub>n</sub> [Kw]	M <sub>t</sub> [daNm]	P <sub>n</sub> [Kw]	M <sub>t</sub> [daNm]	P <sub>n</sub> [Kw]	M <sub>t</sub> [daNm]
5:1	1200	1500	0.39	0.25	0.24	0.15	0.08	0.05	0.07	0.04
	800	1000	0.26	0.25	0.16	0.15	0.07	0.05	0.07	0.04
	600	750	0.20	0.25	0.12	0.15	0.07	0.05	0.07	0.04
	40	50	0.07	0.25	0.07	0.15	0.07	0.05	0.07	0.04

Carico / Load [daN]			500		300		100		50	
Rapporto di riduzione Reduction ratio	Velocità di sollevamento Lifting speed [mm/min]	Giri in entrata Input revs [rpm]	P <sub>n</sub> [Kw]	M <sub>t</sub> [daNm]	P <sub>n</sub> [Kw]	M <sub>t</sub> [daNm]	P <sub>n</sub> [Kw]	M <sub>t</sub> [daNm]	P <sub>n</sub> [Kw]	M <sub>t</sub> [daNm]
20:1	300	1500	0.11	0.07	0.07	0.04	0.07	0.04	0.07	0.04
	200	1000	0.07	0.07	0.07	0.04	0.07	0.04	0.07	0.04
	150	750	0.07	0.07	0.07	0.04	0.07	0.04	0.07	0.04
	10	50	0.07	0.07	0.07	0.04	0.07	0.04	0.07	0.04

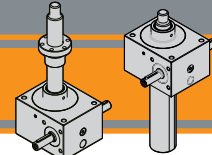

DHT 184

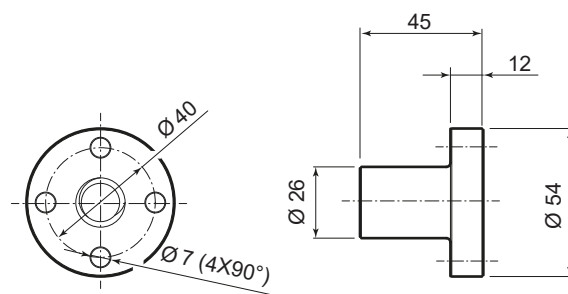
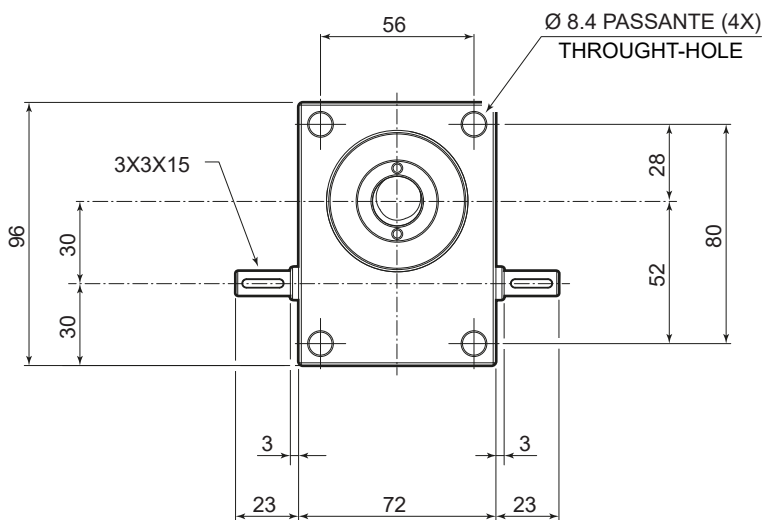
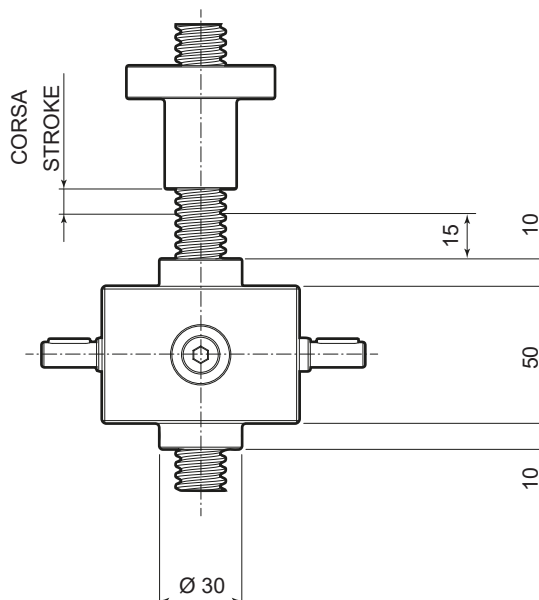
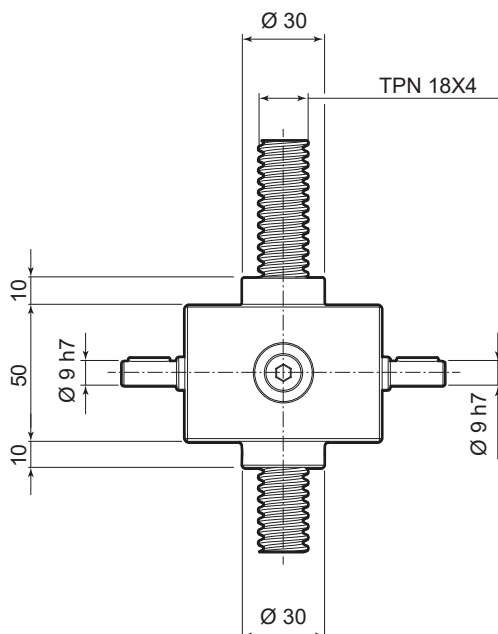

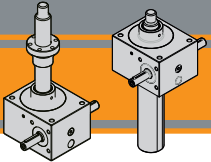

# DHT

## Martinetti a vite trapezia Trapezoidal screw jacks

Dati tecnici

Technical data

### DHT 204

Carico / Load [daN]			1000		600		300		50	
Rapporto di riduzione Reduction ratio	Velocità di sollevamento Lifting speed [mm/min]	Giri in entrata Input revs [rpm]	P <sub>n</sub> [Kw]	M <sub>t</sub> [daNm]	P <sub>n</sub> [Kw]	M <sub>t</sub> [daNm]	P <sub>n</sub> [Kw]	M <sub>t</sub> [daNm]	P <sub>n</sub> [Kw]	M <sub>t</sub> [daNm]
5:1	1200	1500	0.81	0.51	0.49	0.31	0.24	0.15	0.08	0.05
	800	1000	0.54	0.51	0.32	0.31	0.16	0.15	0.07	0.05
	600	750	0.40	0.51	0.24	0.31	0.12	0.15	0.07	0.05
	40	50	0.07	0.51	0.07	0.31	0.07	0.15	0.07	0.05

Carico / Load [daN]			1000		600		300		50	
Rapporto di riduzione Reduction ratio	Velocità di sollevamento Lifting speed [mm/min]	Giri in entrata Input revs [rpm]	P <sub>n</sub> [Kw]	M <sub>t</sub> [daNm]	P <sub>n</sub> [Kw]	M <sub>t</sub> [daNm]	P <sub>n</sub> [Kw]	M <sub>t</sub> [daNm]	P <sub>n</sub> [Kw]	M <sub>t</sub> [daNm]
10:1	600	1500	0.43	0.28	0.26	0.17	0.13	0.08	0.07	0.03
	400	1000	0.29	0.28	0.17	0.17	0.09	0.08	0.07	0.03
	300	750	0.22	0.28	0.13	0.17	0.07	0.08	0.07	0.03
	20	50	0.07	0.28	0.07	0.17	0.07	0.08	0.07	0.03

Carico / Load [daN]			1000		600		300		50	
Rapporto di riduzione Reduction ratio	Velocità di sollevamento Lifting speed [mm/min]	Giri in entrata Input revs [rpm]	P <sub>n</sub> [Kw]	M <sub>t</sub> [daNm]	P <sub>n</sub> [Kw]	M <sub>t</sub> [daNm]	P <sub>n</sub> [Kw]	M <sub>t</sub> [daNm]	P <sub>n</sub> [Kw]	M <sub>t</sub> [daNm]
30:1	200	1500	0.16	0.10	0.09	0.06	0.07	0.03	0.07	0.01
	133	1000	0.10	0.10	0.07	0.06	0.07	0.03	0.07	0.01
	100	750	0.08	0.10	0.07	0.06	0.07	0.03	0.07	0.01
	6.7	50	0.07	0.10	0.07	0.06	0.07	0.03	0.07	0.01



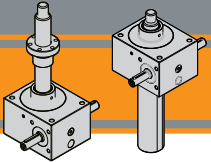

# DHT

## Martinetti a vite trapezia Trapezoidal screw jacks

Dati tecnici

Technical data

### DHT 306

Carico / Load [daN]			2500		1500		750		250	
Rapporto di riduzione Reduction ratio	Velocità di sollevamento Lifting speed [mm/min]	Giri in entrata Input revs [rpm]	P <sub>n</sub> [Kw]	M <sub>t</sub> [daNm]	P <sub>n</sub> [Kw]	M <sub>t</sub> [daNm]	P <sub>n</sub> [Kw]	M <sub>t</sub> [daNm]	P <sub>n</sub> [Kw]	M <sub>t</sub> [daNm]
5:1	1800	1500	3.33	2.12	2.00	1.27	1.00	0.64	0.33	0.21
	1200	1000	2.22	2.12	1.33	1.27	0.67	0.64	0.22	0.21
	900	750	1.67	2.12	1.00	1.27	0.50	0.64	0.17	0.21
	60	50	0.11	2.12	0.07	1.27	0.07	0.64	0.07	0.21

Carico / Load [daN]			2500		1500		750		250	
Rapporto di riduzione Reduction ratio	Velocità di sollevamento Lifting speed [mm/min]	Giri in entrata Input revs [rpm]	P <sub>n</sub> [Kw]	M <sub>t</sub> [daNm]	P <sub>n</sub> [Kw]	M <sub>t</sub> [daNm]	P <sub>n</sub> [Kw]	M <sub>t</sub> [daNm]	P <sub>n</sub> [Kw]	M <sub>t</sub> [daNm]
10:1	900	1500	1.79	1.14	1.07	0.68	0.54	0.34	0.18	0.11
	600	1000	1.19	1.14	0.71	0.68	0.36	0.34	0.12	0.11
	450	750	0.89	1.14	0.54	0.68	0.27	0.34	0.09	0.11
	30	50	0.07	1.14	0.07	0.68	0.07	0.34	0.07	0.11

Carico / Load [daN]			2500		1500		750		250	
Rapporto di riduzione Reduction ratio	Velocità di sollevamento Lifting speed [mm/min]	Giri in entrata Input revs [rpm]	P <sub>n</sub> [Kw]	M <sub>t</sub> [daNm]	P <sub>n</sub> [Kw]	M <sub>t</sub> [daNm]	P <sub>n</sub> [Kw]	M <sub>t</sub> [daNm]	P <sub>n</sub> [Kw]	M <sub>t</sub> [daNm]
30:1	300	1500	0.64	0.41	0.37	0.24	0.19	0.12	0.07	0.04
	200	1000	0.43	0.41	0.26	0.24	0.13	0.12	0.07	0.04
	150	750	0.32	0.41	0.19	0.24	0.10	0.12	0.07	0.04
	10	50	0.07	0.41	0.07	0.24	0.07	0.12	0.07	0.04

Contattare servizio tecnico / Contact technical service

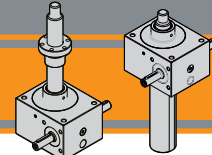

DHT 306

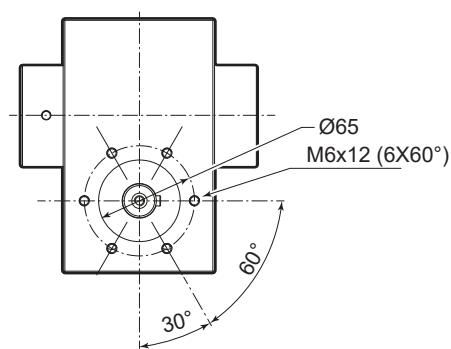
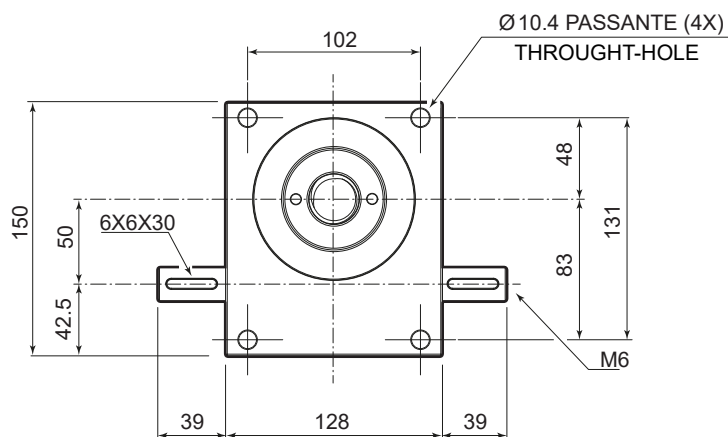
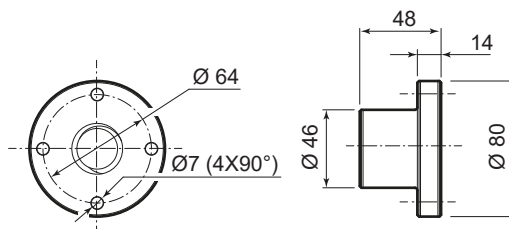
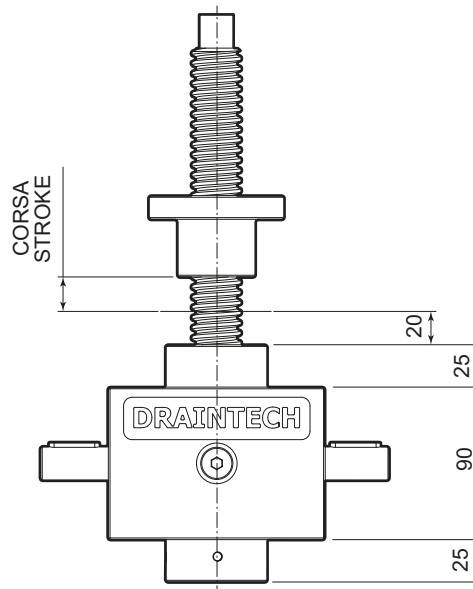
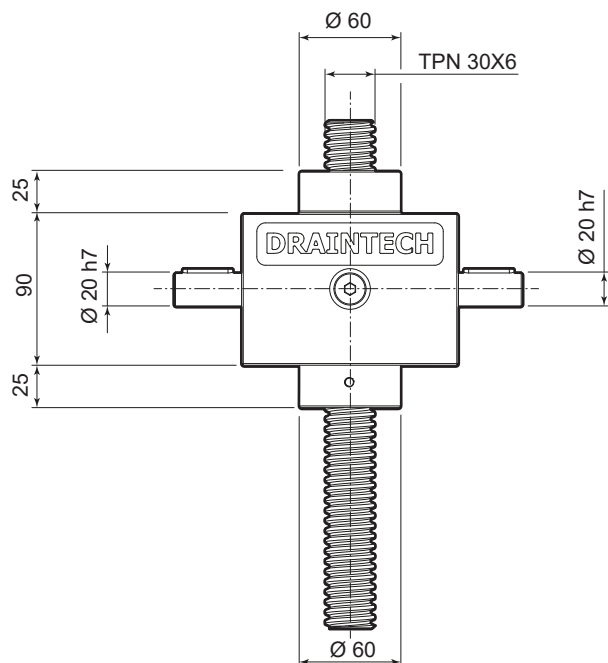

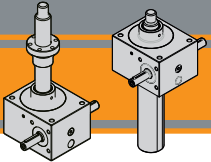

# DHT

## Martinetti a vite trapezia Trapezoidal screw jacks

Dati tecnici

Technical data

### DHT 407

Carico / Load [daN]			5000		3000		1500		500	
Rapporto di riduzione Reduction ratio	Velocità di sollevamento Lifting speed [mm/min]	Giri in entrata Input revs [rpm]	P <sub>n</sub> [Kw]	M <sub>t</sub> [daNm]	P <sub>n</sub> [Kw]	M <sub>t</sub> [daNm]	P <sub>n</sub> [Kw]	M <sub>t</sub> [daNm]	P <sub>n</sub> [Kw]	M <sub>t</sub> [daNm]
5:1	2100	1500	8.34	5.31	5.00	3.18	2.50	1.59	0.83	0.53
	1400	1000	5.56	5.31	3.33	3.18	1.67	1.59	0.56	0.53
	1050	750	4.17	5.31	2.50	3.18	1.25	1.59	0.42	0.53
	70	50	0.28	5.31	0.17	3.18	0.08	1.59	0.07	0.53

Carico / Load [daN]			5000		3000		1500		500	
Rapporto di riduzione Reduction ratio	Velocità di sollevamento Lifting speed [mm/min]	Giri in entrata Input revs [rpm]	P <sub>n</sub> [Kw]	M <sub>t</sub> [daNm]	P <sub>n</sub> [Kw]	M <sub>t</sub> [daNm]	P <sub>n</sub> [Kw]	M <sub>t</sub> [daNm]	P <sub>n</sub> [Kw]	M <sub>t</sub> [daNm]
10:1	1050	1500	4.47	2.84	2.68	1.71	1.34	0.85	0.45	0.28
	700	1000	2.98	2.84	1.79	1.71	0.89	0.85	0.30	0.28
	525	750	2.23	2.84	1.34	1.71	0.67	0.85	0.22	0.28
	30	50	0.15	2.84	0.09	1.71	0.07	0.85	0.07	0.28

Carico / Load [daN]			5000		3000		1500		500	
Rapporto di riduzione Reduction ratio	Velocità di sollevamento Lifting speed [mm/min]	Giri in entrata Input revs [rpm]	P <sub>n</sub> [Kw]	M <sub>t</sub> [daNm]	P <sub>n</sub> [Kw]	M <sub>t</sub> [daNm]	P <sub>n</sub> [Kw]	M <sub>t</sub> [daNm]	P <sub>n</sub> [Kw]	M <sub>t</sub> [daNm]
30:1	350	1500	1.60	1.02	0.96	0.61	0.48	0.31	0.16	0.10
	233.3	1000	1.07	1.02	0.64	0.61	0.32	0.31	0.11	0.10
	175	750	0.80	1.02	0.48	0.61	0.24	0.31	0.08	0.10
	11.7	50	0.07	1.02	0.07	0.61	0.07	0.31	0.07	0.10

Contattare servizio tecnico / Contact technical service

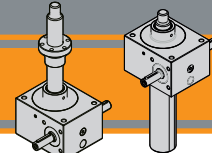

DHT 407

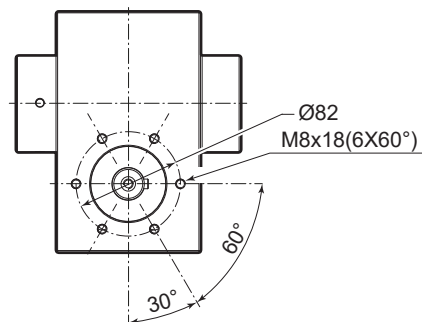
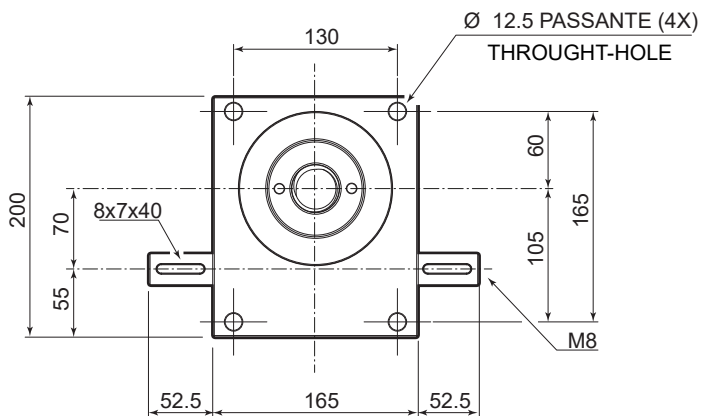
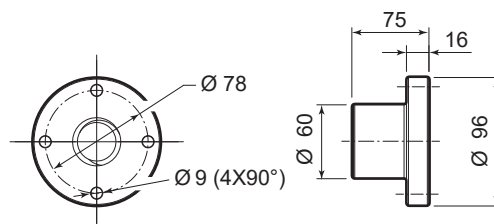
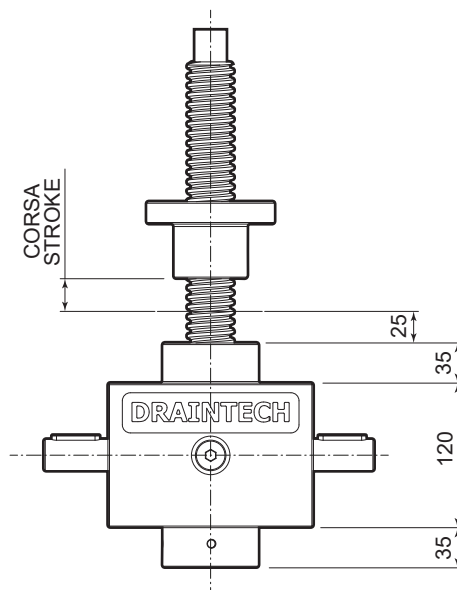
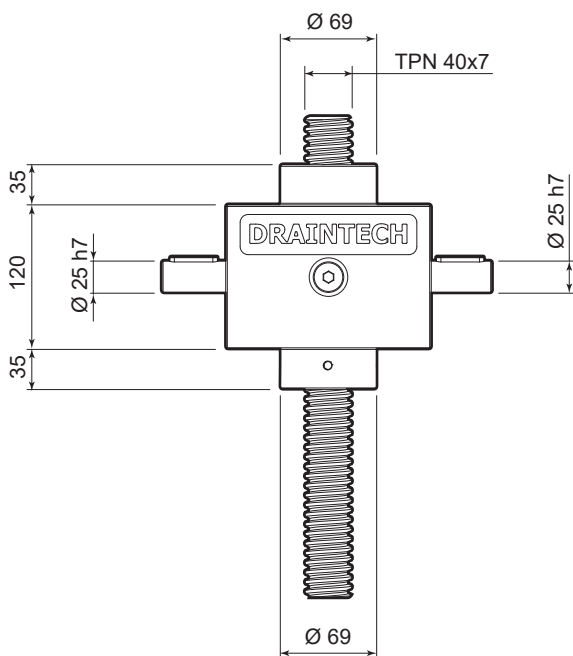

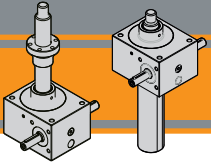

# DHT

## Martinetti a vite trapezia Trapezoidal screw jacks

Dati tecnici

Technical data

### DHT 559

Carico / Load [daN]			10000		5000		3000		1000	
Rapporto di riduzione Reduction ratio	Velocità di sollevamento Lifting speed [mm/min]	Giri in entrata Input revs [rpm]	P <sub>n</sub> [Kw]	M <sub>t</sub> [daNm]	P <sub>n</sub> [Kw]	M <sub>t</sub> [daNm]	P <sub>n</sub> [Kw]	M <sub>t</sub> [daNm]	P <sub>n</sub> [Kw]	M <sub>t</sub> [daNm]
5:1	2700	1500	23.09	14.70	11.54	7.35	6.93	4.41	2.31	1.47
	1800	1000	15.39	14.70	7.70	7.35	4.62	4.41	1.54	1.47
	1350	750	11.54	14.70	5.77	7.35	3.46	4.41	1.15	1.47
	90	50	0.77	14.70	0.38	7.35	0.23	4.41	0.08	1.47

Carico / Load [daN]			10000		5000		3000		1000	
Rapporto di riduzione Reduction ratio	Velocità di sollevamento Lifting speed [mm/min]	Giri in entrata Input revs [rpm]	P <sub>n</sub> [Kw]	M <sub>t</sub> [daNm]	P <sub>n</sub> [Kw]	M <sub>t</sub> [daNm]	P <sub>n</sub> [Kw]	M <sub>t</sub> [daNm]	P <sub>n</sub> [Kw]	M <sub>t</sub> [daNm]
10:1	1350	1500	12.37	7.87	6.18	3.94	3.71	2.36	1.24	0.79
	900	1000	8.25	7.87	4.12	3.94	2.47	2.36	0.82	0.79
	675	750	6.18	7.87	3.09	3.94	1.86	2.36	0.62	0.79
	45	50	0.41	7.87	0.21	3.94	0.12	2.36	0.07	0.79

Carico / Load [daN]			10000		5000		3000		1000	
Rapporto di riduzione Reduction ratio	Velocità di sollevamento Lifting speed [mm/min]	Giri in entrata Input revs [rpm]	P <sub>n</sub> [Kw]	M <sub>t</sub> [daNm]	P <sub>n</sub> [Kw]	M <sub>t</sub> [daNm]	P <sub>n</sub> [Kw]	M <sub>t</sub> [daNm]	P <sub>n</sub> [Kw]	M <sub>t</sub> [daNm]
30:1	450	1500	4.44	2.83	2.22	1.41	1.33	0.85	0.44	0.28
	300	1000	2.96	2.83	1.48	1.41	0.89	0.85	0.30	0.28
	225	750	2.22	2.83	1.11	1.41	0.67	0.85	0.22	0.28
	15	50	0.15	2.83	0.07	1.41	0.07	0.85	0.07	0.28

Contattare servizio tecnico / Contact technical service

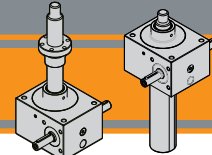

DHT 559

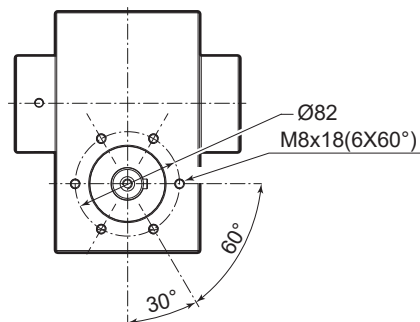
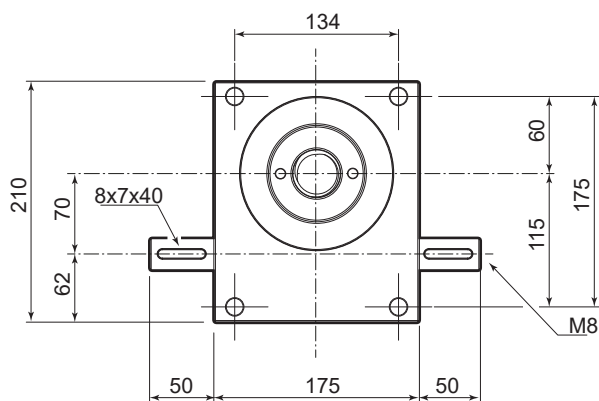
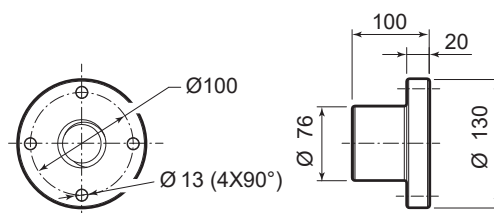
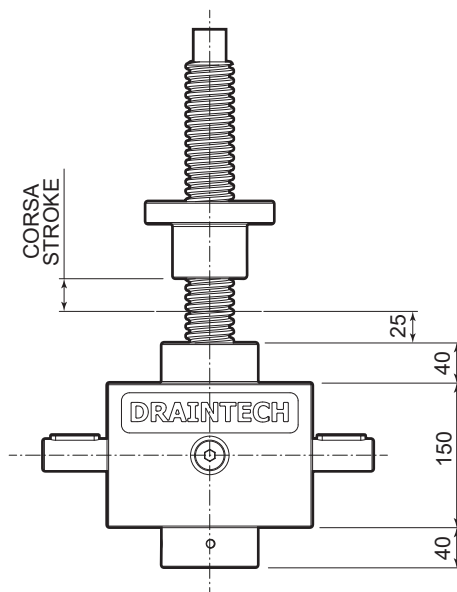
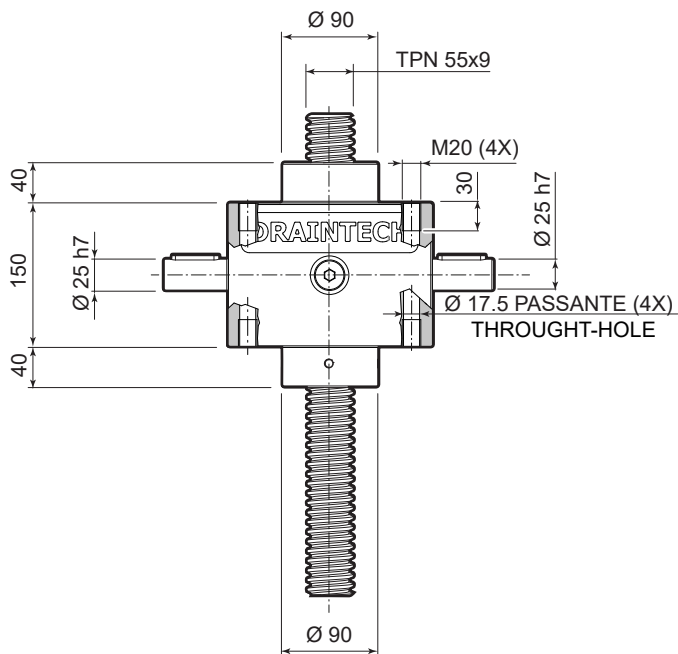

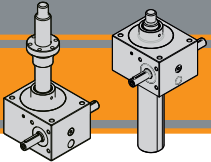

# DHT

## Martinetti a vite trapezia Trapezoidal screw jacks

Dati tecnici

Technical data

### DHT 609

Carico / Load [daN]			15000		7500		5000		2000	
Rapporto di riduzione Reduction ratio	Velocità di sollevamento Lifting speed [mm/min]	Giri in entrata Input revs [rpm]	P <sub>n</sub> [Kw]	M <sub>t</sub> [daNm]	P <sub>n</sub> [Kw]	M <sub>t</sub> [daNm]	P <sub>n</sub> [Kw]	M <sub>t</sub> [daNm]	P <sub>n</sub> [Kw]	M <sub>t</sub> [daNm]
5:1	2700	1500	35.17	22.39	17.59	11.20	11.72	7.46	4.69	2.99
	1800	1000	23.45	22.39	11.72	11.20	7.82	7.46	3.13	2.99
	1350	750	17.59	22.39	8.79	11.20	5.86	7.46	2.34	2.99
	90	50	1.17	22.39	0.59	11.20	0.39	7.46	0.16	2.99

Carico / Load [daN]			15000		7500		5000		2000	
Rapporto di riduzione Reduction ratio	Velocità di sollevamento Lifting speed [mm/min]	Giri in entrata Input revs [rpm]	P <sub>n</sub> [Kw]	M <sub>t</sub> [daNm]	P <sub>n</sub> [Kw]	M <sub>t</sub> [daNm]	P <sub>n</sub> [Kw]	M <sub>t</sub> [daNm]	P <sub>n</sub> [Kw]	M <sub>t</sub> [daNm]
10:1	1350	1500	18.76	11.94	9.38	5.97	6.25	3.98	2.50	1.59
	900	1000	12.51	11.94	6.25	5.97	4.17	3.98	1.67	1.59
	675	750	9.38	11.94	4.69	5.97	3.13	3.98	1.25	1.59
	45	50	0.63	11.94	0.31	5.97	0.21	3.98	0.07	1.59

Carico / Load [daN]			15000		7500		5000		2000	
Rapporto di riduzione Reduction ratio	Velocità di sollevamento Lifting speed [mm/min]	Giri in entrata Input revs [rpm]	P <sub>n</sub> [Kw]	M <sub>t</sub> [daNm]	P <sub>n</sub> [Kw]	M <sub>t</sub> [daNm]	P <sub>n</sub> [Kw]	M <sub>t</sub> [daNm]	P <sub>n</sub> [Kw]	M <sub>t</sub> [daNm]
30:1	450	1500	6.70	4.27	3.35	2.23	2.23	1.42	0.89	0.57
	300	1000	4.47	4.27	2.23	2.13	1.49	1.42	0.60	0.57
	225	750	3.35	4.27	1.67	1.12	1.12	1.42	0.45	0.57
	15	50	0.22	4.27	0.11	0.07	0.07	1.42	0.07	0.57

Contattare servizio tecnico / Contact technical service

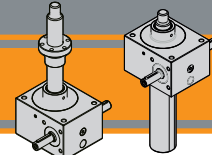

DHT 609

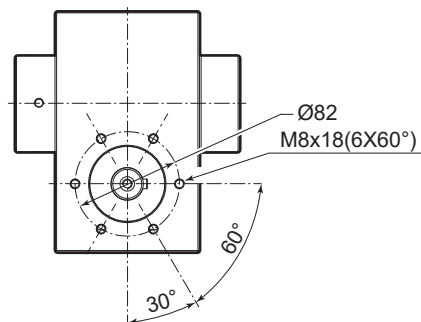
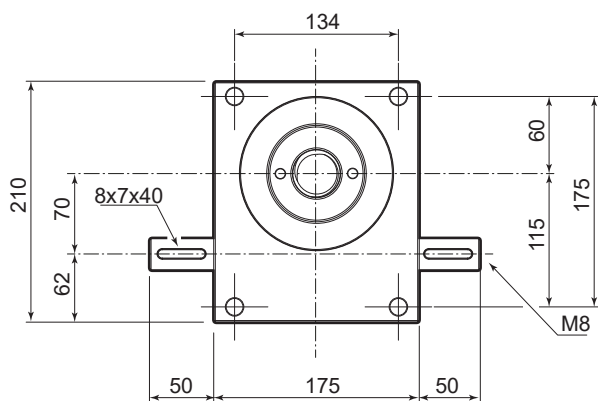
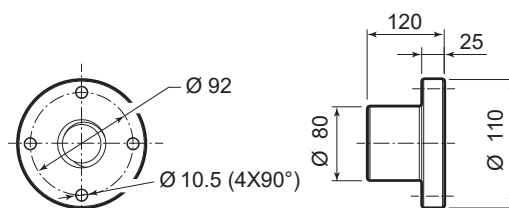
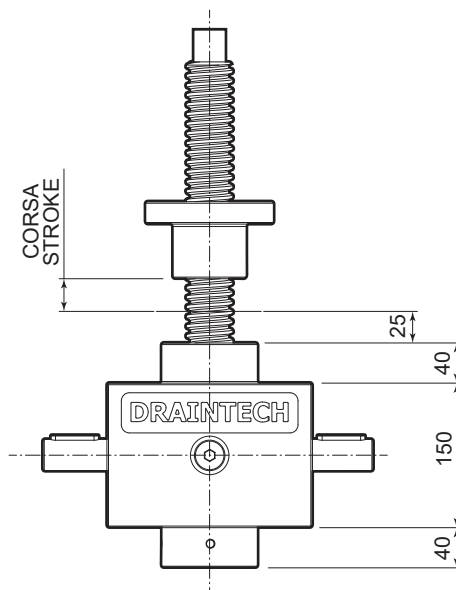
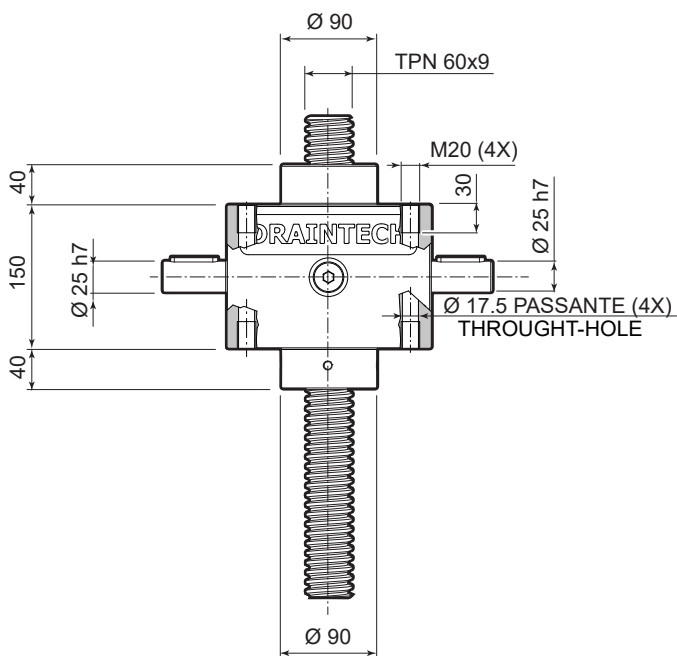

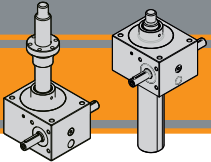

# DHT

## Martinetti a vite trapezia Trapezoidal screw jacks

Dati tecnici

Technical data

### DHT 7010

Carico / Load [daN]			20000		15000		7500		2500	
Rapporto di riduzione Reduction ratio	Velocità di sollevamento Lifting speed [mm/min]	Giri in entrata Input revs [rpm]	P <sub>n</sub> [Kw]	M <sub>t</sub> [daNm]	P <sub>n</sub> [Kw]	M <sub>t</sub> [daNm]	P <sub>n</sub> [Kw]	M <sub>t</sub> [daNm]	P <sub>n</sub> [Kw]	M <sub>t</sub> [daNm]
5:1	3000	1500	53	34	39	25	20	13	7	4
	2000	1000	35	34	26	25	13	13	4	4
	1500	750	26	34	20	25	10	13	3	4
	100	50	2	34	1	25	1	13	0.22	4

Carico / Load [daN]			20000		15000		7500		2500	
Rapporto di riduzione Reduction ratio	Velocità di sollevamento Lifting speed [mm/min]	Giri in entrata Input revs [rpm]	P <sub>n</sub> [Kw]	M <sub>t</sub> [daNm]	P <sub>n</sub> [Kw]	M <sub>t</sub> [daNm]	P <sub>n</sub> [Kw]	M <sub>t</sub> [daNm]	P <sub>n</sub> [Kw]	M <sub>t</sub> [daNm]
10:1	1500	1500	22	14	17	10	8	5	2	1
	1000	1000	15	14	11	10	5	5	1	1
	750	750	11	14	8	10	3	5	1.46	1
	50	50	1	14	1	10	0.29	5	0.10	1

Carico / Load [daN]			20000		15000		7500		2500	
Rapporto di riduzione Reduction ratio	Velocità di sollevamento Lifting speed [mm/min]	Giri in entrata Input revs [rpm]	P <sub>n</sub> [Kw]	M <sub>t</sub> [daNm]	P <sub>n</sub> [Kw]	M <sub>t</sub> [daNm]	P <sub>n</sub> [Kw]	M <sub>t</sub> [daNm]	P <sub>n</sub> [Kw]	M <sub>t</sub> [daNm]
30:1	500	1500	10	6	7	5	4	2	1	0.79
	333	1000	7	6	5	5	3	2	1	0.79
	250	750	5	6	4	5	2	2	1	0.79
	16.7	50	0.33	6	0.25	5	0.07	2	0.07	0.79

Contattare servizio tecnico / Contact technical service

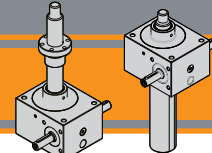

DHT 7010

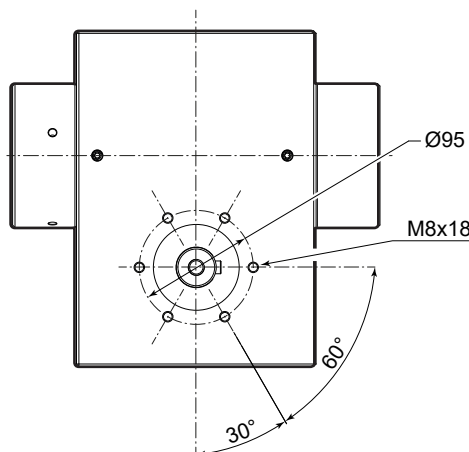
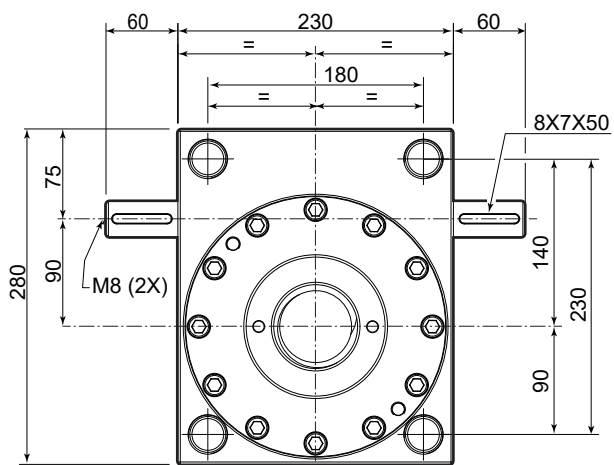
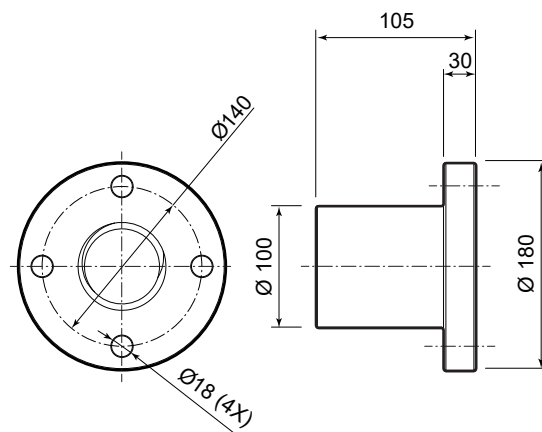
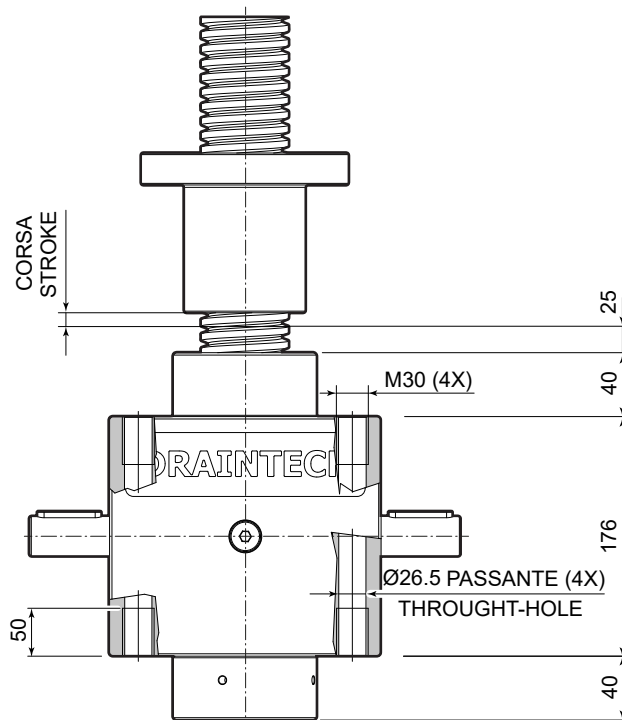
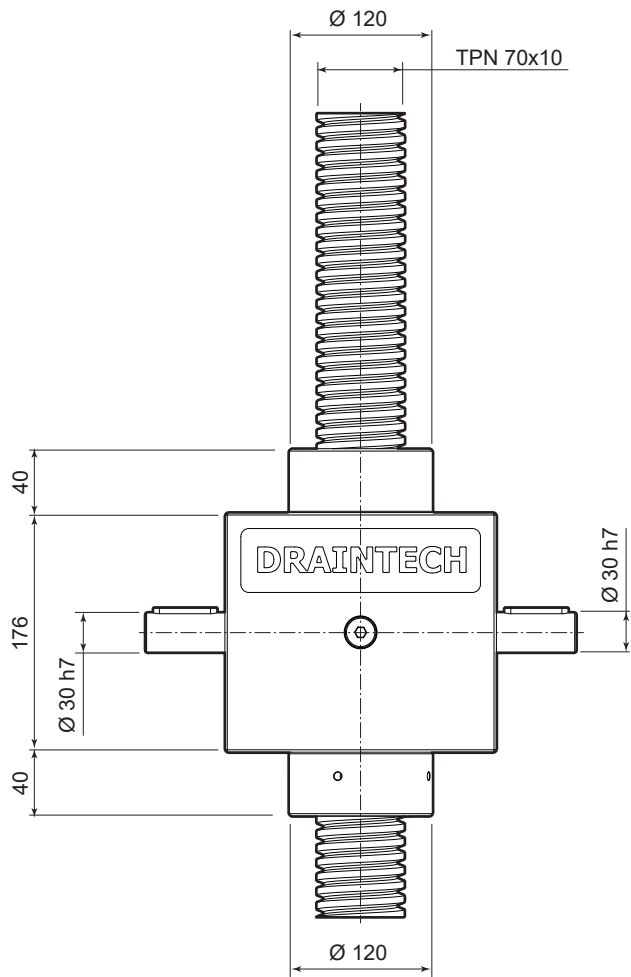

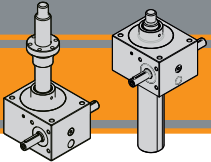

# DHT

## Martinetti a vite trapezia Trapezoidal screw jacks

Dati tecnici

Technical data

### DHT 8010

Carico / Load [daN]			25000		20000		10000		5000	
Rapporto di riduzione Reduction ratio	Velocità di sollevamento Lifting speed [mm/min]	Giri in entrata Input revs [rpm]	P <sub>n</sub> [Kw]	M <sub>t</sub> [daNm]	P <sub>n</sub> [Kw]	M <sub>t</sub> [daNm]	P <sub>n</sub> [Kw]	M <sub>t</sub> [daNm]	P <sub>n</sub> [Kw]	M <sub>t</sub> [daNm]
5:1	3000	1500	56.00	36.00	45.00	29.00	22.00	15.00	11.00	7.00
	2000	1000	37.00	36.00	30.00	29.00	15.00	15.00	7.00	7.00
	1500	750	28.00	36.00	22.00	29.00	11.00	15.00	6.00	7.00
	100	50	2.00	36.00	1.00	29.00	1.00	15.00	0.38	7.00

Carico / Load [daN]			25000		20000		10000		5000	
Rapporto di riduzione Reduction ratio	Velocità di sollevamento Lifting speed [mm/min]	Giri in entrata Input revs [rpm]	P <sub>n</sub> [Kw]	M <sub>t</sub> [daNm]	P <sub>n</sub> [Kw]	M <sub>t</sub> [daNm]	P <sub>n</sub> [Kw]	M <sub>t</sub> [daNm]	P <sub>n</sub> [Kw]	M <sub>t</sub> [daNm]
10:1	1500	1500	30.00	19.00	24.00	15.00	11.00	7.00	6.00	4.00
	1000	1000	20.00	19.00	15.00	15.00	7.00	7.00	4.00	4.00
	750	750	15.00	19.00	11.00	15.00	5.00	7.00	3.00	4.00
	50	50	1.00	19.00	0.82	15.00	0.41	7.00	0.21	4.00

Carico / Load [daN]			25000		20000		10000		5000	
Rapporto di riduzione Reduction ratio	Velocità di sollevamento Lifting speed [mm/min]	Giri in entrata Input revs [rpm]	P <sub>n</sub> [Kw]	M <sub>t</sub> [daNm]	P <sub>n</sub> [Kw]	M <sub>t</sub> [daNm]	P <sub>n</sub> [Kw]	M <sub>t</sub> [daNm]	P <sub>n</sub> [Kw]	M <sub>t</sub> [daNm]
30:1	500	1500	15.00	9.00	12.00	8.00	6.00	4.00	3.00	2.00
	333	1000	10.00	9.00	8.00	8.00	4.00	4.00	2.00	2.00
	250	750	7.00	9.00	6.00	8.00	3.00	4.00	1.00	2.00
	16.7	50	0.48	9.00	0.39	8.00	0.20	4.00	0.10	2.00

Contattare servizio tecnico / Contact technical service

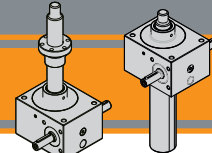

DHT 8010

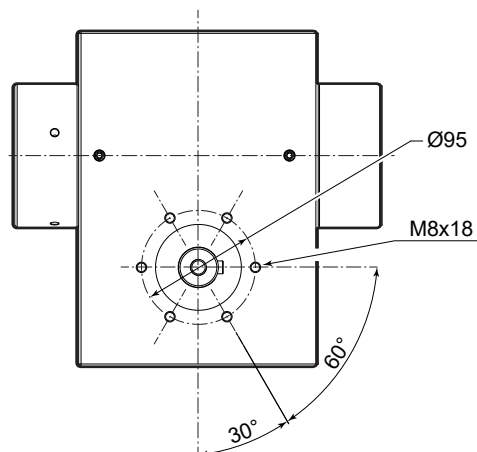
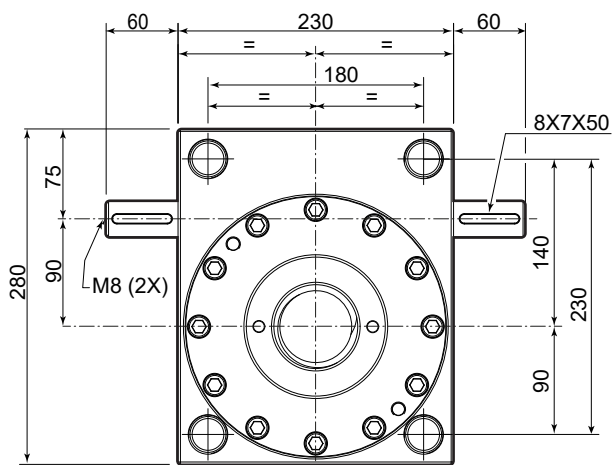
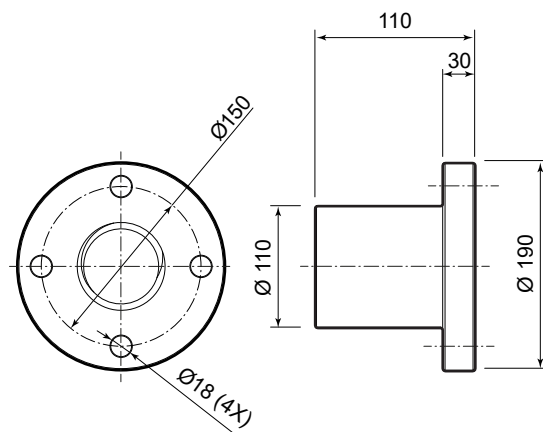
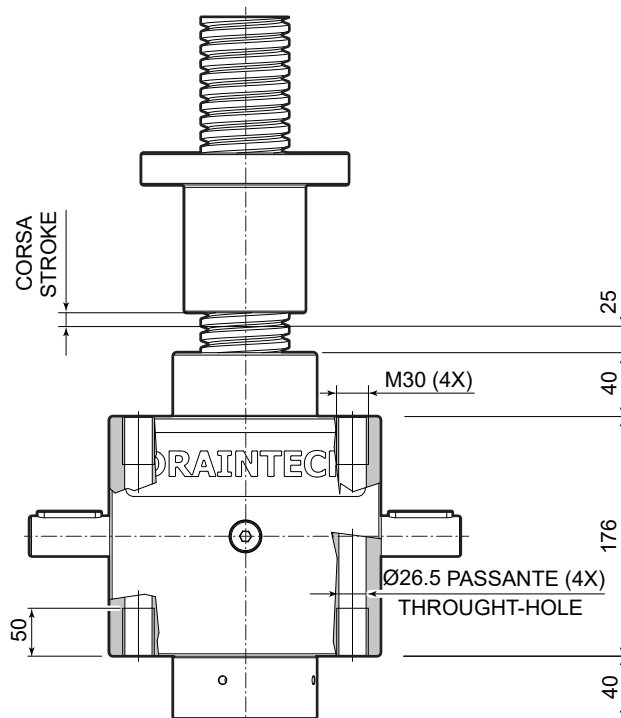
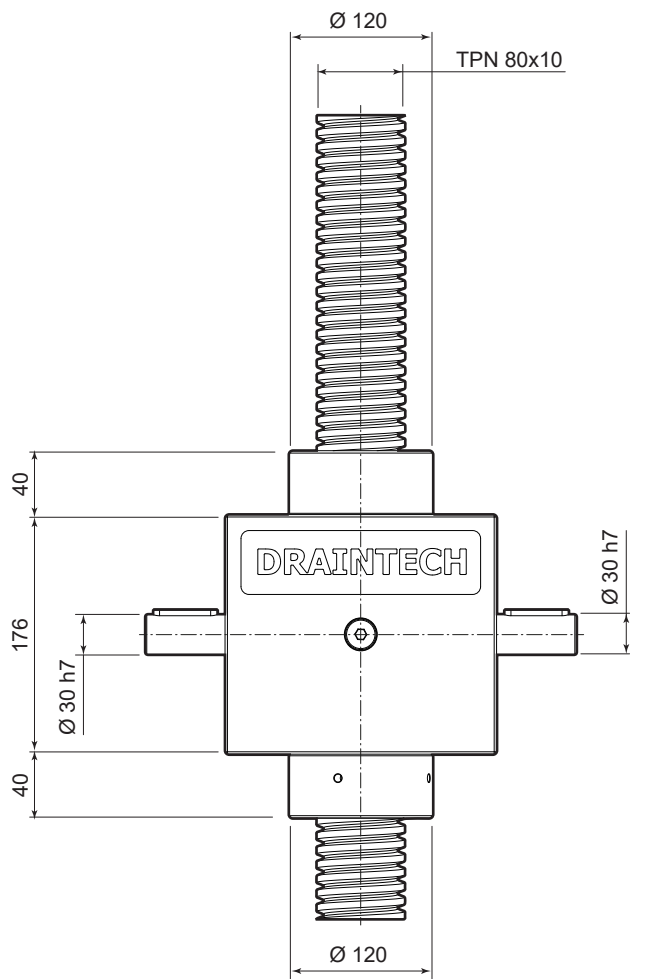

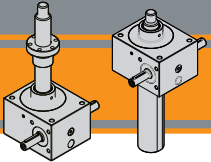

# DHT

## Martinetti a vite trapezia Trapezoidal screw jacks

Dati tecnici

Technical data

### DHT 9010

Carico / Load [daN]			35000		20000		10000		5000	
Rapporto di riduzione Reduction ratio	Velocità di sollevamento Lifting speed [mm/min]	Giri in entrata Input revs [rpm]	P <sub>n</sub> [Kw]	M <sub>t</sub> [daNm]	P <sub>n</sub> [Kw]	M <sub>t</sub> [daNm]	P <sub>n</sub> [Kw]	M <sub>t</sub> [daNm]	P <sub>n</sub> [Kw]	M <sub>t</sub> [daNm]
5:1	3000	1500	114.00	74.00	65.00	42.00	33.00	21.00	16.00	11.00
	2000	1000	76.00	74.00	44.00	42.00	22.00	21.00	11.00	11.00
	1500	750	57.00	74.00	33.00	42.00	16.00	21.00	8.00	11.00
	100	50	4.00	74.00	2.00	42.00	1.00	21.00	0.60	11.00

Carico / Load [daN]			35000		20000		10000		5000	
Rapporto di riduzione Reduction ratio	Velocità di sollevamento Lifting speed [mm/min]	Giri in entrata Input revs [rpm]	P <sub>n</sub> [Kw]	M <sub>t</sub> [daNm]	P <sub>n</sub> [Kw]	M <sub>t</sub> [daNm]	P <sub>n</sub> [Kw]	M <sub>t</sub> [daNm]	P <sub>n</sub> [Kw]	M <sub>t</sub> [daNm]
10:1	1800	1500	57.00	37.00	33.00	21.00	16.00	11.00	8.00	5.00
	1200	1000	38.00	37.00	22.00	21.00	11.00	11.00	0.30	5.00
	900	750	29.00	37.00	16.00	21.00	8.00	11.00	4.00	5.00
	60	50	2.00	37.00	1.00	21.00	0.60	11.00	0.21	5.00

Carico / Load [daN]			35000		20000		10000		5000	
Rapporto di riduzione Reduction ratio	Velocità di sollevamento Lifting speed [mm/min]	Giri in entrata Input revs [rpm]	P <sub>n</sub> [Kw]	M <sub>t</sub> [daNm]	P <sub>n</sub> [Kw]	M <sub>t</sub> [daNm]	P <sub>n</sub> [Kw]	M <sub>t</sub> [daNm]	P <sub>n</sub> [Kw]	M <sub>t</sub> [daNm]
30:1	600	1500	29.00	19.00	16.00	11.00	8.00	5.00	4.00	3.00
	400	1000	19.00	19.00	11.00	11.00	6.00	5.00	3.00	3.00
	300	750	14.00	19.00	8.00	11.00	4.00	5.00	2.00	3.00
	20	50	1.00	19.00	6.00	11.00	0.30	5.00	0.20	3.00

 Contattare servizio tecnico / Contact technical service



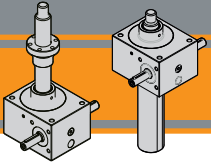

# DHT

## Martinetti a vite trapezia Trapezoidal screw jacks

Dati tecnici

Technical data

### DHT 12014

Carico / Load [daN]			35000		20000		10000		5000	
Rapporto di riduzione Reduction ratio	Velocità di sollevamento Lifting speed [mm/min]	Giri in entrata Input revs [rpm]	P <sub>n</sub> [Kw]	M <sub>t</sub> [daNm]	P <sub>n</sub> [Kw]	M <sub>t</sub> [daNm]	P <sub>n</sub> [Kw]	M <sub>t</sub> [daNm]	P <sub>n</sub> [Kw]	M <sub>t</sub> [daNm]
10:1	2100	1500	121.0	79.0	81.0	52.5	40.5	26.0	20.3	13.25
	1050	1000	60.0	79.0	40.5	52.5	20.3	26.0	10.3	13.25
	420	750	24.0	79.0	16.0	52.5	8.07	26.0	4.0	13.25
	70	50	4.0	79.0	2.7	52.5	1.35	26.0	0.69	13.25

Carico / Load [daN]			35000		20000		10000		5000	
Rapporto di riduzione Reduction ratio	Velocità di sollevamento Lifting speed [mm/min]	Giri in entrata Input revs [rpm]	P <sub>n</sub> [Kw]	M <sub>t</sub> [daNm]	P <sub>n</sub> [Kw]	M <sub>t</sub> [daNm]	P <sub>n</sub> [Kw]	M <sub>t</sub> [daNm]	P <sub>n</sub> [Kw]	M <sub>t</sub> [daNm]
30:1	700	1500	62.0	40.0	41.8	27.0	21.0	14.0	10.5	6.8
	460	1000	31.5	40.0	21.0	27.0	10.5	14.0	5.5	6.8
	350	750	12.6	40.0	8.4	27.0	4.2	14.0	2.0	6.8
	23	50	2.0	40.0	1.4	27.0	0.7	14.0	0.4	6.8

 Contattare servizio tecnico / Contact technical service

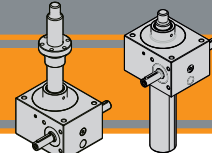

DHT 12014

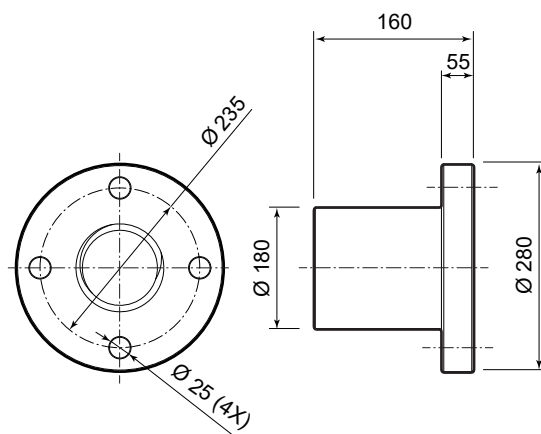
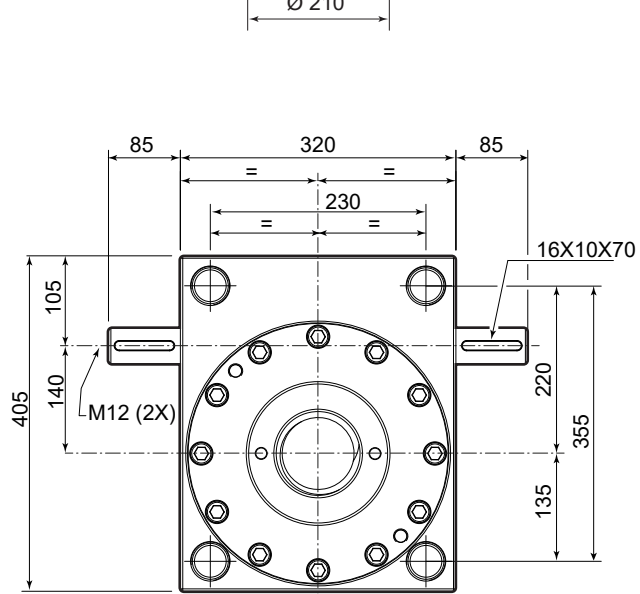
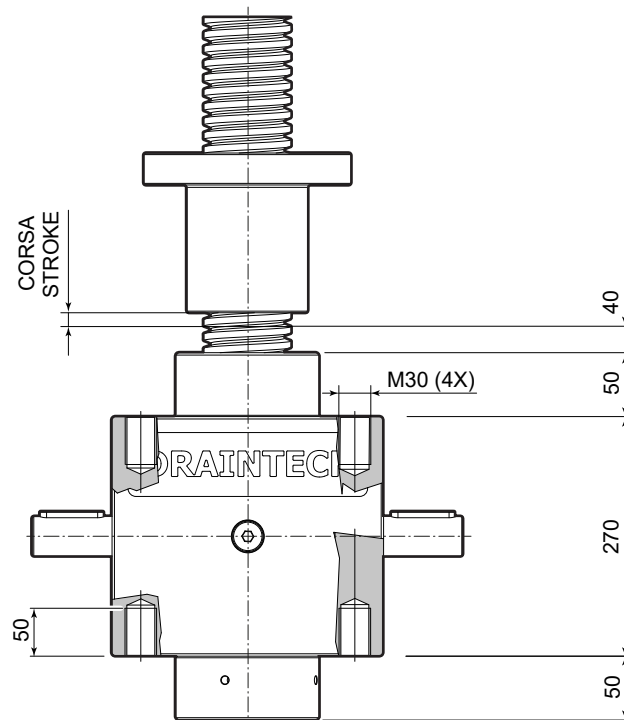
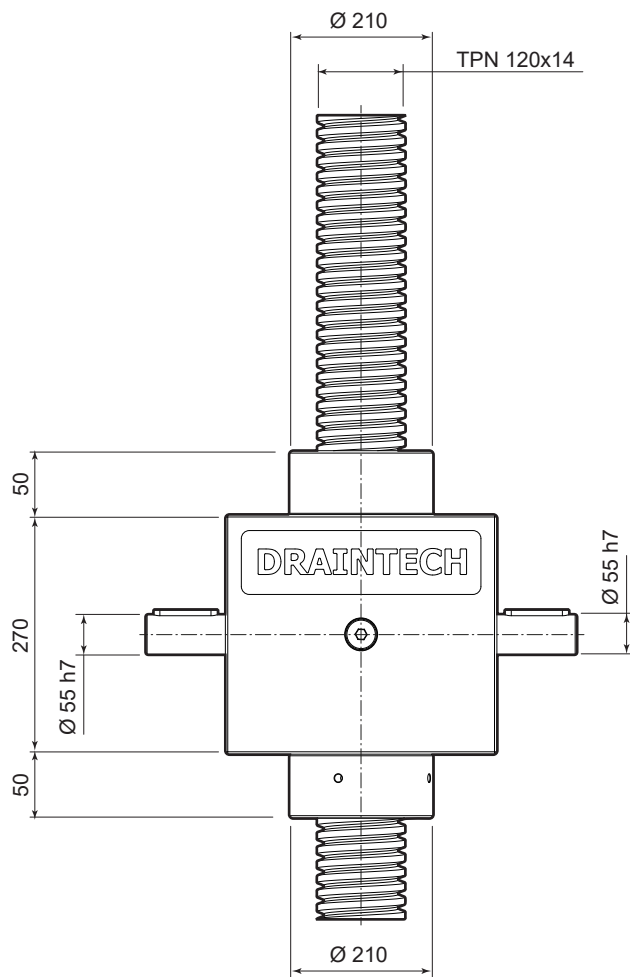

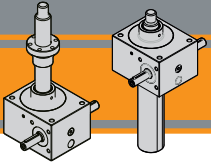

# DHT

## Martinetti a vite trapezia Trapezoidal screw jacks

Dati tecnici

Technical data

### DHT 16016

Carico / Load [daN]			80000		60000		40000		20000		10000	
Rapporto di riduzione Reduction ratio	Velocità di sollevamento Lifting speed [mm/min]	Giri in entrata Input revs [rpm]	P <sub>n</sub> [kW]	M <sub>t</sub> [daNm]	P <sub>n</sub> [kW]	M <sub>t</sub> [daNm]	P <sub>n</sub> [kW]	M <sub>t</sub> [daNm]	P <sub>n</sub> [kW]	M <sub>t</sub> [daNm]	P <sub>n</sub> [kW]	M <sub>t</sub> [daNm]
12:1	2000	1500	170.0	110.0	131.0	85.0	87.0	56.5	43.6	28.0	22.0	14.0
	1000	750	83.0	110.0	65.4	85.0	43.6	56.5	21.8	28.0	11.0	14.0
	400	300	32.0	110.0	26.1	85.0	17.4	56.5	8.7	28.0	4.3	14.0
	66.6	50	5.0	110.0	4.4	85.0	3.0	56.5	1.5	28.0	0.7	14.0

Carico / Load [daN]			80000		60000		40000		20000		10000	
Rapporto di riduzione Reduction ratio	Velocità di sollevamento Lifting speed [mm/min]	Giri in entrata Input revs [rpm]	P <sub>n</sub> [kW]	M <sub>t</sub> [daNm]	P <sub>n</sub> [kW]	M <sub>t</sub> [daNm]	P <sub>n</sub> [kW]	M <sub>t</sub> [daNm]	P <sub>n</sub> [kW]	M <sub>t</sub> [daNm]	P <sub>n</sub> [kW]	M <sub>t</sub> [daNm]
36:1	666	1500	95.0	61.0	73.0	47.2	48.4	31.5	24.2	15.7	12.0	7.8
	333	750	47.0	61.0	36.3	47.2	24.2	31.5	12.0	15.7	6.0	7.8
	133	300	18.5	61.0	14.5	47.2	9.7	31.5	4.8	15.7	2.4	7.8
	22	50	3.0	61.0	2.4	47.2	1.6	31.5	0.8	15.7	0.4	7.8



Contattare servizio tecnico / Contact technical service

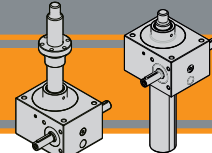

DHT 16016

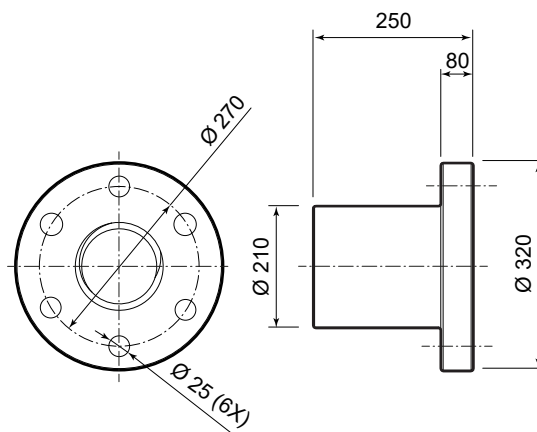
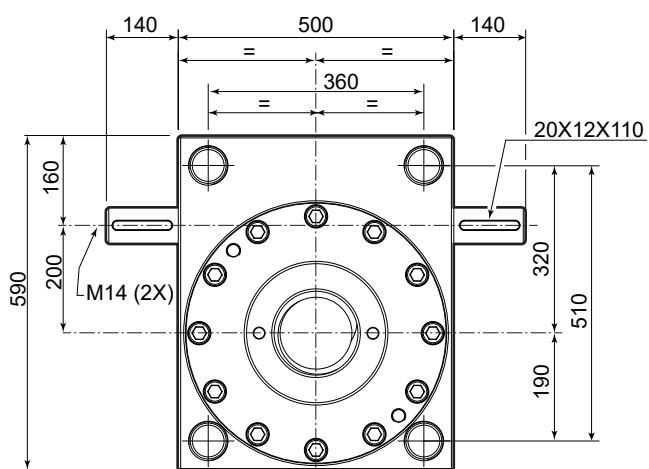
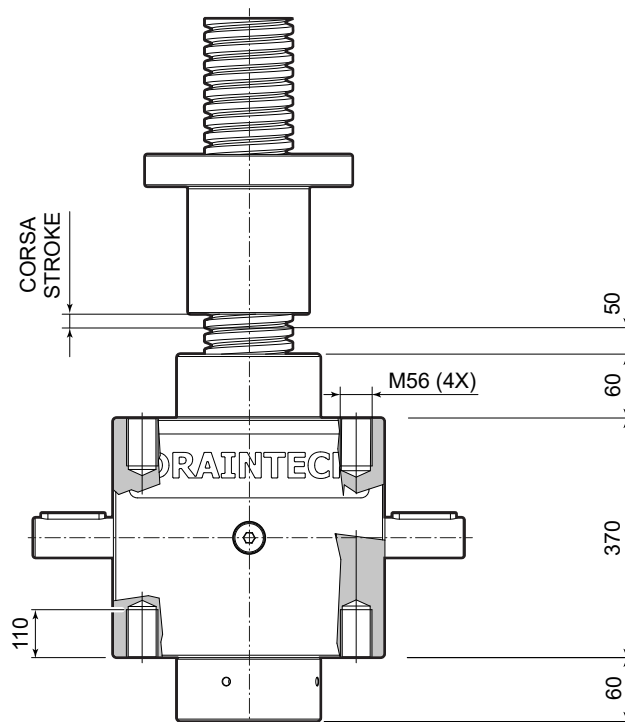
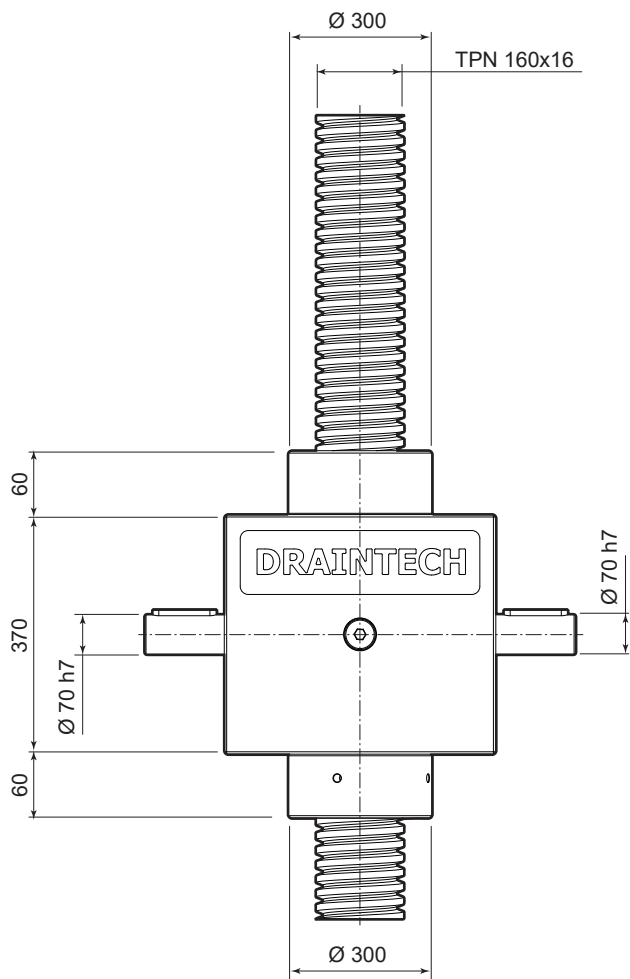

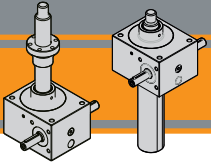

**DHT**

Martinetti a vite trapezia  
*Trapezoidal screw jacks*

**Screw  
Jacks**

**NEW!**

Martinetti per aste a ricircolo di sfere  
**Ball screw jacks**





## HS

Predisposto per vite a ricircolo  
*Prepared for ball-screw*

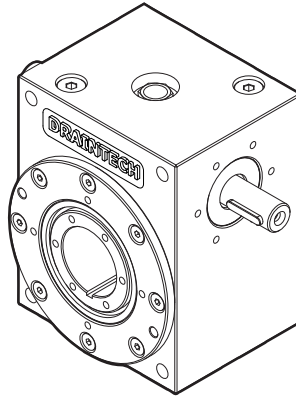

## HST

Traslante  
*Translating*

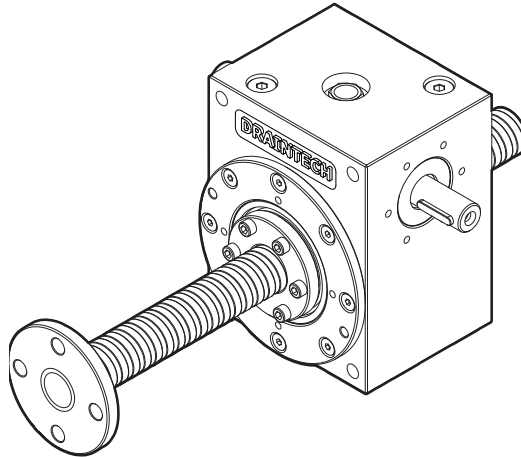

## HSR

Rotante  
*Rotating*

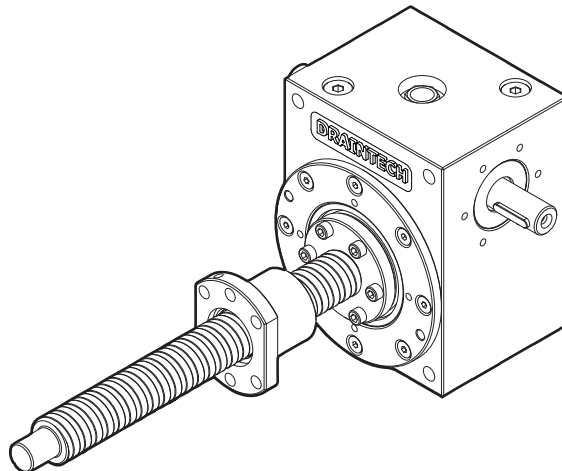



<b>Indice</b>	<b>Index</b>	Pag. Page
Caratteristiche tecniche	<i>Technical features</i>	<b>C4</b>
Designazione	<i>Designation</i>	<b>C5</b>
Forma costruttiva	<i>Constructive forms</i>	<b>C5</b>
Motori applicabili	<i>Applicable motors</i>	<b>C6</b>
Direzioni di rotazione e di movimento	<i>Rotation and movement directions</i>	<b>C7</b>
Dati tecnici - HS70	<i>Technical data - HS70</i>	<b>C8</b>
Dati tecnici - HS100	<i>Technical data - HS100</i>	<b>C10</b>
Dati tecnici - HS120	<i>Technical data - HS120</i>	<b>C12</b>
Chiocciolate	<i>Nuts</i>	<b>C14</b>

Questa sezione annulla e sostituisce ogni precedente edizione o revisione. Qualora questa sezione non Vi sia giunta in distribuzione controllata, l'aggiornamento dei dati ivi contenuto non è assicurato. **In tal caso la versione più aggiornata è disponibile sul nostro sito internet [www.transtecno.com](http://www.transtecno.com)**

*This section replaces any previous edition and revision. If you obtained this catalogue other than through controlled distribution channels, the most up to date content is not guaranteed. **In this case the latest version is available on our web site [www.transtecno.com](http://www.transtecno.com)***



### Caratteristiche generali

### General features

Dall'esperienza Draintech nella costruzione dei martinetti ad asta trapezia nasce la serie HS per aste a ricircolo di sfere. Questi martinetti sono adatti per trasmissioni lineari con alti rendimenti, alte velocità, precisione e fattore di servizio continuo.

Il loro utilizzo può avvenire singolarmente o in configurazioni composte da più martinetti collegati tra di loro tramite alberi di trasmissione e giunti permettendo la realizzazione di sistemi di sollevamento ed azionamenti perfettamente bilanciati anche con carichi non uniformemente distribuiti.

Il prodotto è rigorosamente made in Italy e l'impiego di materiali con alte prestazioni meccaniche quali :

- Carter: ghisa sferoidale
- Viti senza fine (VSF): acciaio 16NiCrMo5 cementato e temprato con profili rettificati
- Ruota elicoidale: bronzo GB-CuSn12 DIN 17656

Rispetto ai martinetti ad asta trapezia serie DHT, questa serie presenta una reversibilità della trasmissione ed è necessario prevedere freni, per evitare l'inversione del moto.

From Draintech's experience in the construction of trapezoidal screw jacks, the ball screw jacks of the HS series have been developed.

These screw jacks are suitable for linear drives with high efficiencies, high speeds, precision and continuous service factor. They can be used singly or in configurations consisting of several screw jacks connected to each other via drive shafts and couplings, allowing the creation of perfectly balanced lifting and drive systems even with unevenly distributed loads.

The product is strictly made in Italy and uses materials with high mechanical performance such as:

- Casing: spheroidal cast iron
- Worm screws (VSF): steel 16NiCrMo5 case-hardened and hardened with ground profiles
- Helical gear: bronze GB-CuSn12 DIN 17656

Compared to the DHT series trapezoidal rod screw jacks, this series has a reversible drive and brakes are required to prevent reversal of motion.

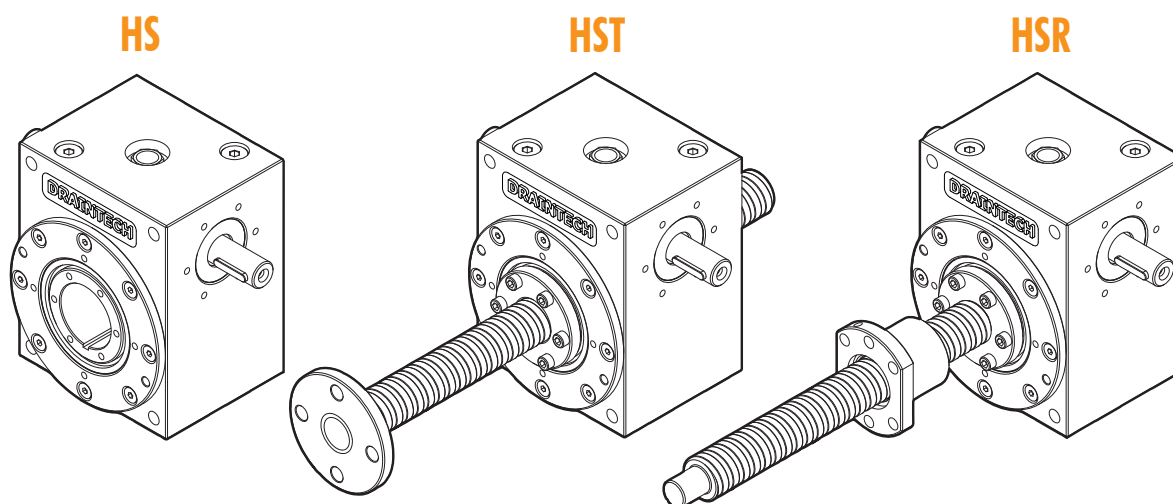

Caratteristiche generali / General features				
Taglia Size		70	100	120
Portata massima Maximum flow rate	[kN]	Vedi tabelle prestazionali See performance tables		
Potenza massima applicabile Maximum applicable power	[kW]	Vedi tabelle prestazionali See performance tables		
Rapporto di riduzione Reduction ratio		5	5	5
Interasse Centre distance	[mm]	59	88	117
Efficiency	[%]	85	86	86
Peso martinetto Screw jack weight	[kg]	14.7	39	63
Carichi laterali ammissibili Permissible side loads	[N]	Non sono ammessi carichi laterali Side loads are not permitted		
Temperature d'esercizio Operating temperatures	[°C]	- 10 - 80		
Velocità massima in ingresso Maximum input speed	[rpm]	3000		
Condizioni di lavoro standard Standard working conditions		a temperatura di 20°C - funzionamento regolare at a temperature of 20°C - smooth operation		
Momento di inerzia Moment of inertia	[kgmm <sup>2</sup> ]	0.004	0.025	0.079



Designazione

Designation

**MARTINETTI HS / HS SCREW JACKS**

HS	100	C500	R105	TF	FSA	FC	63B14
Tipo Type	Taglia Size	Corsa Stroke	Rapporto di riduzione Reduction ratio	Terminale Terminal	Forma costruttiva Constructive form	Accessori Accessories	Grandezza flangia motore Motor flange size
HS HST HSR	70 100 120		105 1:5	see p. D4-D5 see page D4-D5	AB AD AS FSA FS FDA FD	PO PR NG PRO AS PE ARO FCO PL FCP FC RGT SP TS GR	63 B5 63 B14 71 B5 71 B14 80 B5 80 B14 90 B5 90 B14 100/112 B5 100/112 B14 132 B5 * 13 B14

\* Contattare il nostro Ufficio Tecnico / Contact our Technical Department

Forma costruttiva

Constructive forms

Per definizione la forma costruttiva è identificata osservando il martinetto con il terminale rivolto verso l'osservatore. In questo modo sono identificabili le posizioni a destra o a sinistra sia degli alberi sia delle flange

By definition, the construction form is identified by observing the screw jack with the end facing the observer. In this way, the left or right positions of both shafts and flanges can be identified

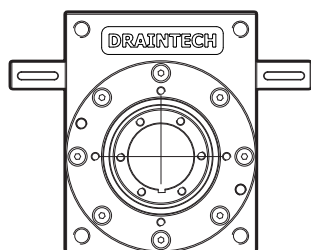

**AB**  
Albero bisporgente  
Double ended shaft

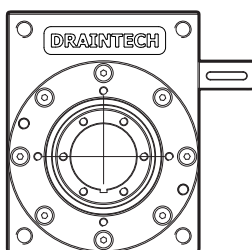

**AD**  
Albero a destra  
Right-hand shaft

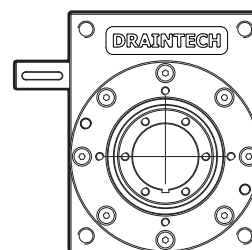

**AS**  
Albero a sinistra  
Left-hand shaft

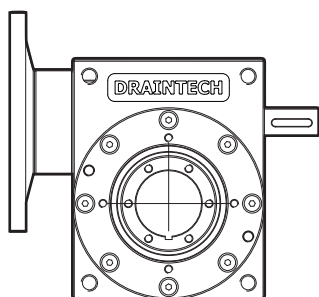

**FSA**  
Flangia a sinistra + albero  
Left flange + shaft

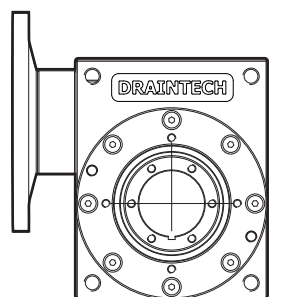

**FS**  
Flangia a sinistra  
Left flange

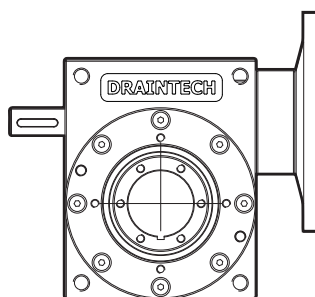

**FDA**  
Flangia a destra + albero  
Right flange + shaft

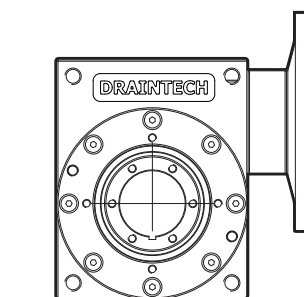

**FD**  
Flangia a destra  
Right flange



### Motori applicabili

### Applicable motors

Tutti i nostri martinetti sono fornibili nella loro versione motorizzata. Abbiamo pertanto reso disponibile una vasta gamma di predisposizioni attacco motore corrispondenti agli standard IEC fino alla 132 in B5 e B14.

All our screw jacks are available in their motorised version. We have therefore made available a wide range of motor connection arrangements corresponding to IEC standards up to 132 in B5 and B14.

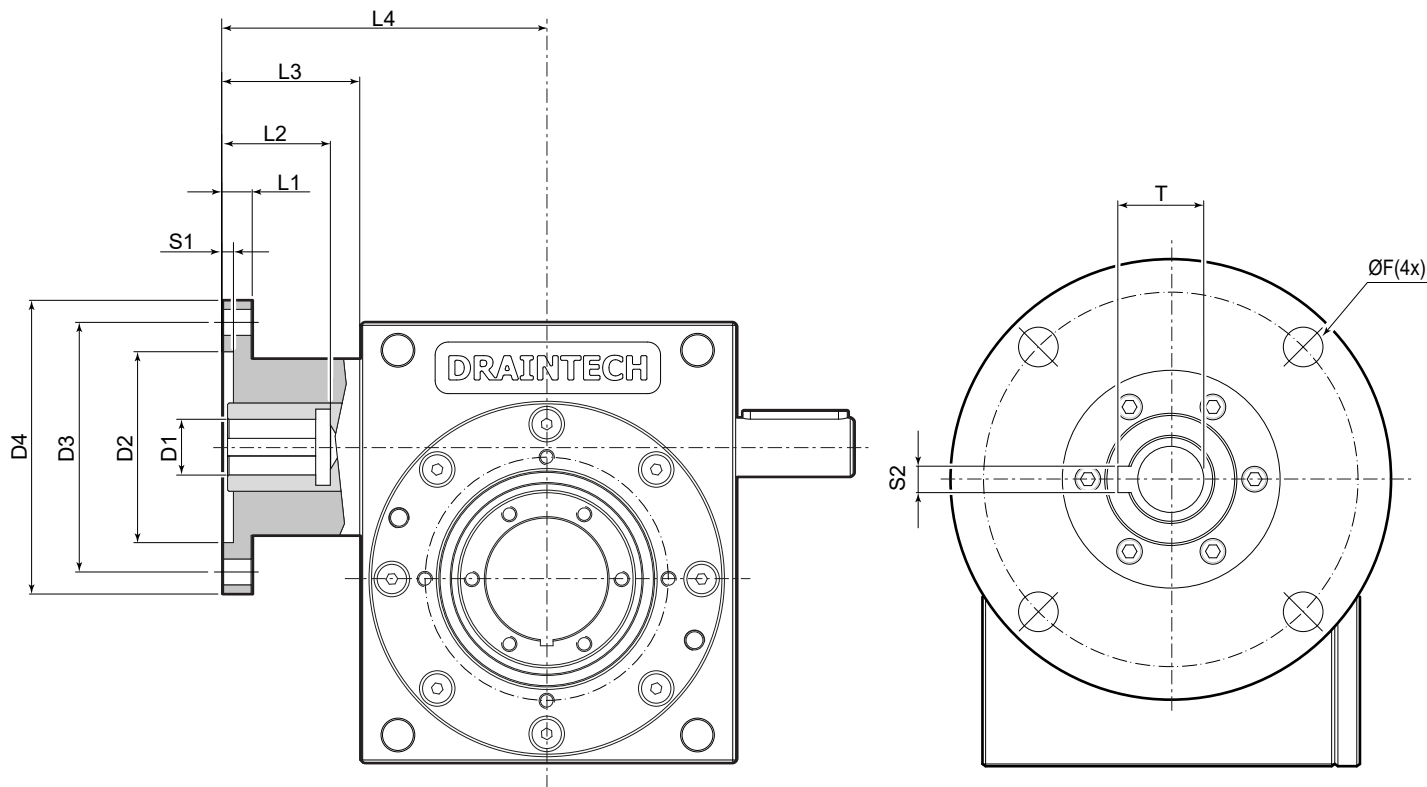

Flange motore IEC / IEC motor flanges													
Taglia Size	Flangia Flange	D1 H7	D2 H7	D3	D4	ØF	L3	L1	L2	L4	S1	S2	T
70	63 B5	11	95	115	140	9	48.5	10	45	118.5	4	4	12.8
	63 B14	11	60	75	90	5,5	48.5	6	45	118.5	6	4	12.8
	71 B5	14	110	130	160	9	48.5	10	45	118.5	4	5	16.3
	71 B14	14	70	85	105	8	48.5	9	45	118.5	4	5	16.3
	80 B5	19	130	165	200	11	48.5	10	45	118.5	4	6	21.8
	80 B14	19	80	100	120	6.6	48.5	10	45	118.5	4	6	21.8
	90B5	24	130	165	200	11	48.5	10	45	118.5	4	6	21.8
100	71 B5	14	110	130	160	9	66.5	11	58	166.5	4,5	5	16.3
	71 B14	14	70	85	105	8	66.5	9	45	166.5	4	5	16.3
	80 B5	19	130	165	200	11	66.5	11	58	166.5	4,5	6	21.8
	80 B14	19	80	100	120	6.6	66.5	11	58	166.5	4,5	6	21.8
	90 B5	24	130	165	200	11	66.5	11	58	166.5	4,5	8	27.3
	90 B14	24	95	115	140	9	66.5	11	58	166.5	4,5	8	27.3
	100-112 B5	28	180	215	250	13.5	66.5	11	58	166.5	4.5	8	31.3
100-112 B14	28	110	130	160	9	66.5	11	58	166.5	4.5	8	31.3	
120	90 B5	24	130	165	200	11	83	11	75	203	4.5	8	31.3
	100-112 B5	28	180	215	250	13.5	83	13.5	75	203	6.5	8	31.3
	100-112 B14	28	110	130	160	9	83	13.5	75	203	6.5	8	31.3
	132 B5	Contattare il nostro Ufficio Tecnico / Contact our Technical Department											
	132 B14	38	130	165	200	11	83	11	85.5	203	4.5	10	41.3



**Direzione di rotazione e di movimento**

**Direction of rotation and movement**

*I martinetti standard HS vengono forniti con vite senza fine destra a cui corrispondono i sensi di rotazione e di movimento riportati nelle figure sottostanti.*

Standard HS screw jacks are supplied with a right-hand worm screw corresponding to the directions of rotation and movement shown in the figures below.

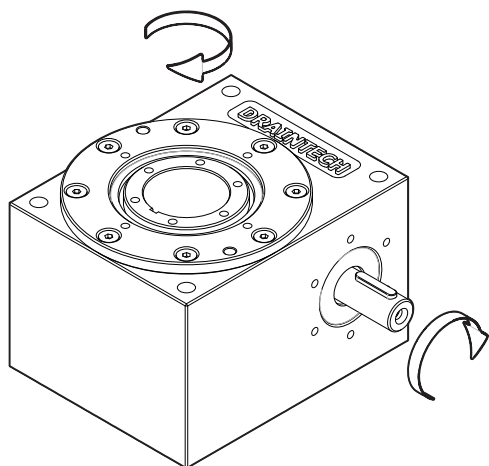

**HS**  
 Predisposto per vite a ricircolo / Prepared for ball-screw

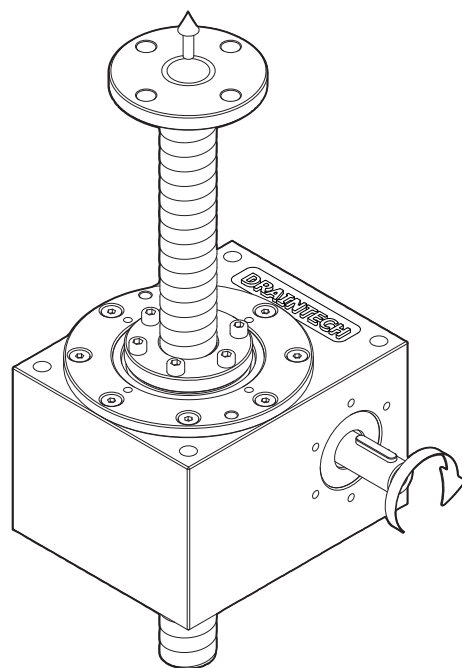

**HST**  
 Traslate / Translating

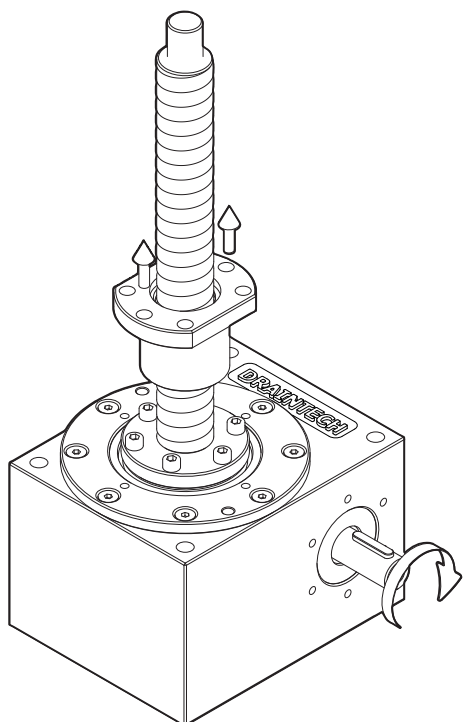

**HSR**  
 Rotante / Rotating



## HS/HST/HSR 70

Velocità in ingresso Input speed	$n_1$ [rpm]	3000	2500	2000	1500	1000	800
Velocità in uscita Output speed	$n_2$ [rpm]	600	500	400	300	200	160
Coppia in ingresso Input torque	$M_1$ [Nm]	18.7	20.8	21.8	23.0	24.3	24.8
Rendimento riduzione Reduction efficiency	[%]	0.85	0.85	0.85	0.85	0.85	0.85
Coppia in uscita Output torque	$M_2$ [Nm]	79.5	88.4	92.7	97.5	103.1	105.5
Potenza massima in ingresso Maximum input power	$P_{max}$ [kW]	5.9	5.4	4.6	3.6	2.5	2.1

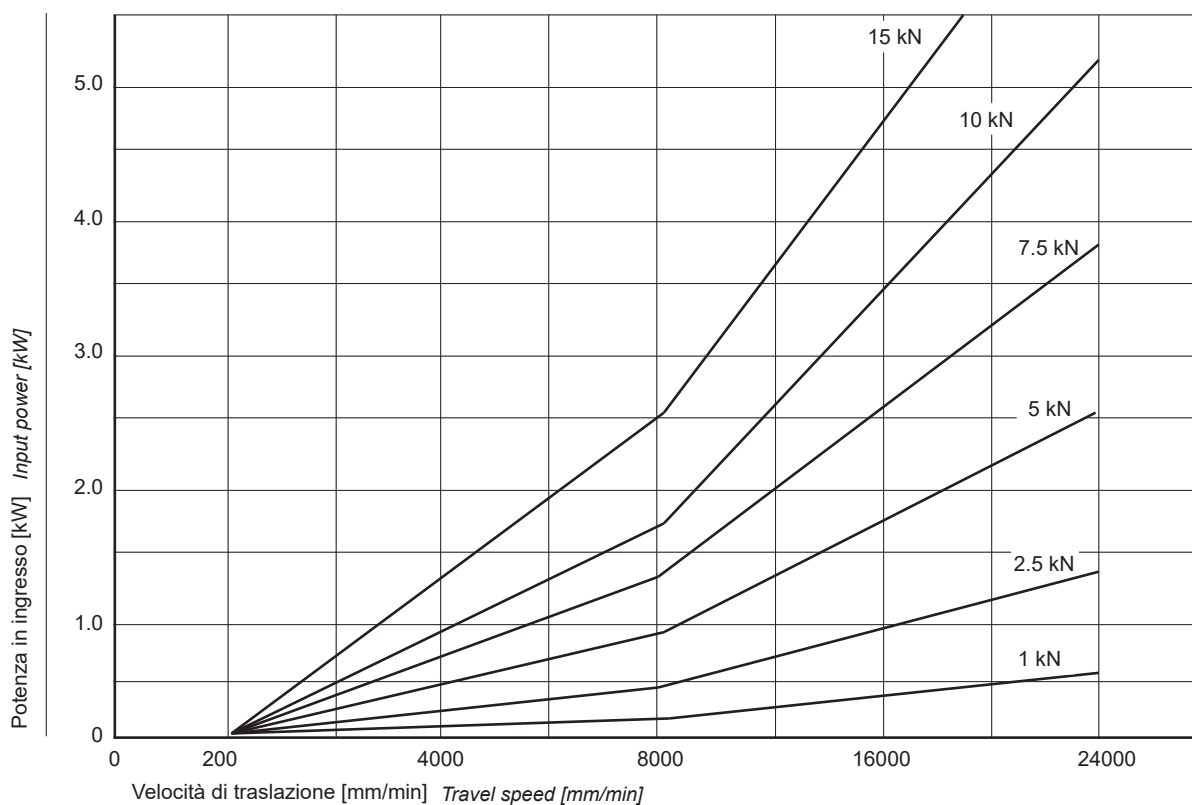



## HS/HST/HSR 70

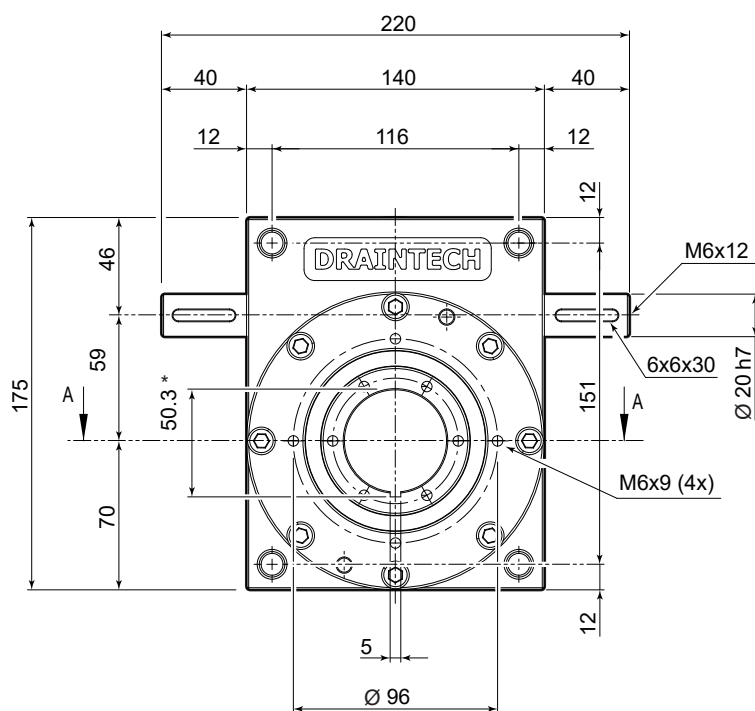
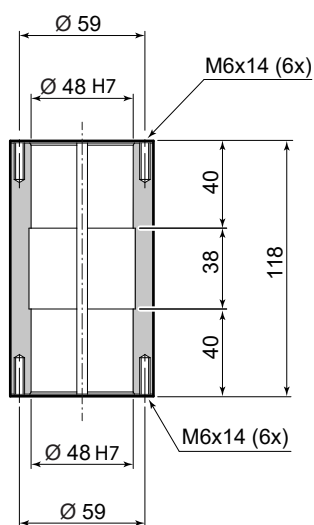
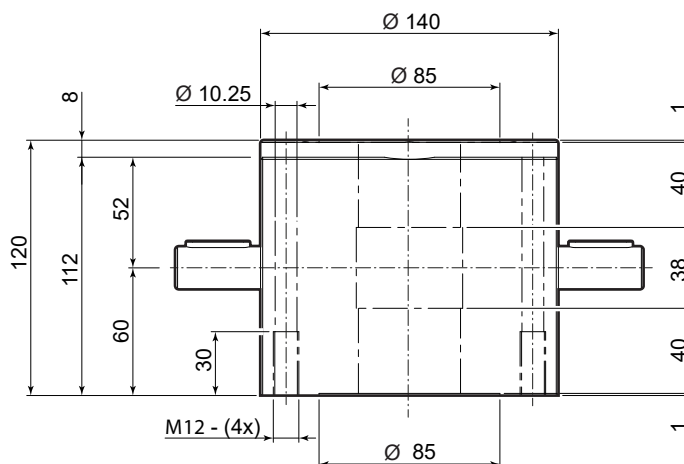
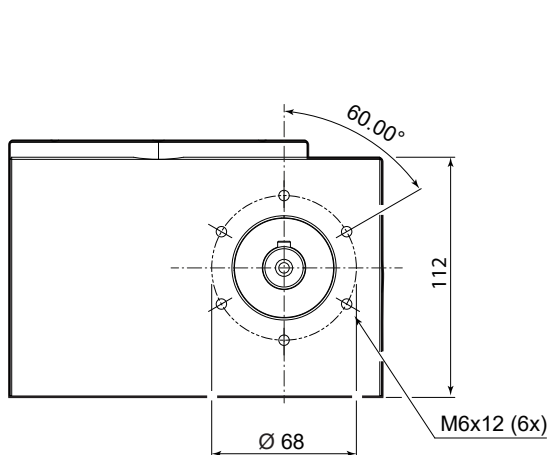

\* lavorazione sede linguetta eseguita a richiesta  
*tab seat machining carried out on request*



## HS/HST/HSR 100

Velocità in ingresso Input speed	$n_1$ [rpm]	3000	2500	2000	1500	1000	800
Velocità in uscita Output speed	$n_2$ [rpm]	600	500	400	300	200	160
Coppia in ingresso Input torque	$M_1$ [Nm]	44.4	50.0	57.2	66.9	80.5	87.5
Rendimento riduzione Reduction efficiency	[%]	0.86	0.86	0.86	0.86	0.86	0.86
Coppia in uscita Output torque	$M_2$ [Nm]	190.9	215.0	246.0	287.7	346.1	376.3
Potenza massima in ingresso Maximum input power	$P_{max}$ [kW]	13.9	13.1	12.0	10.5	8.4	7.3

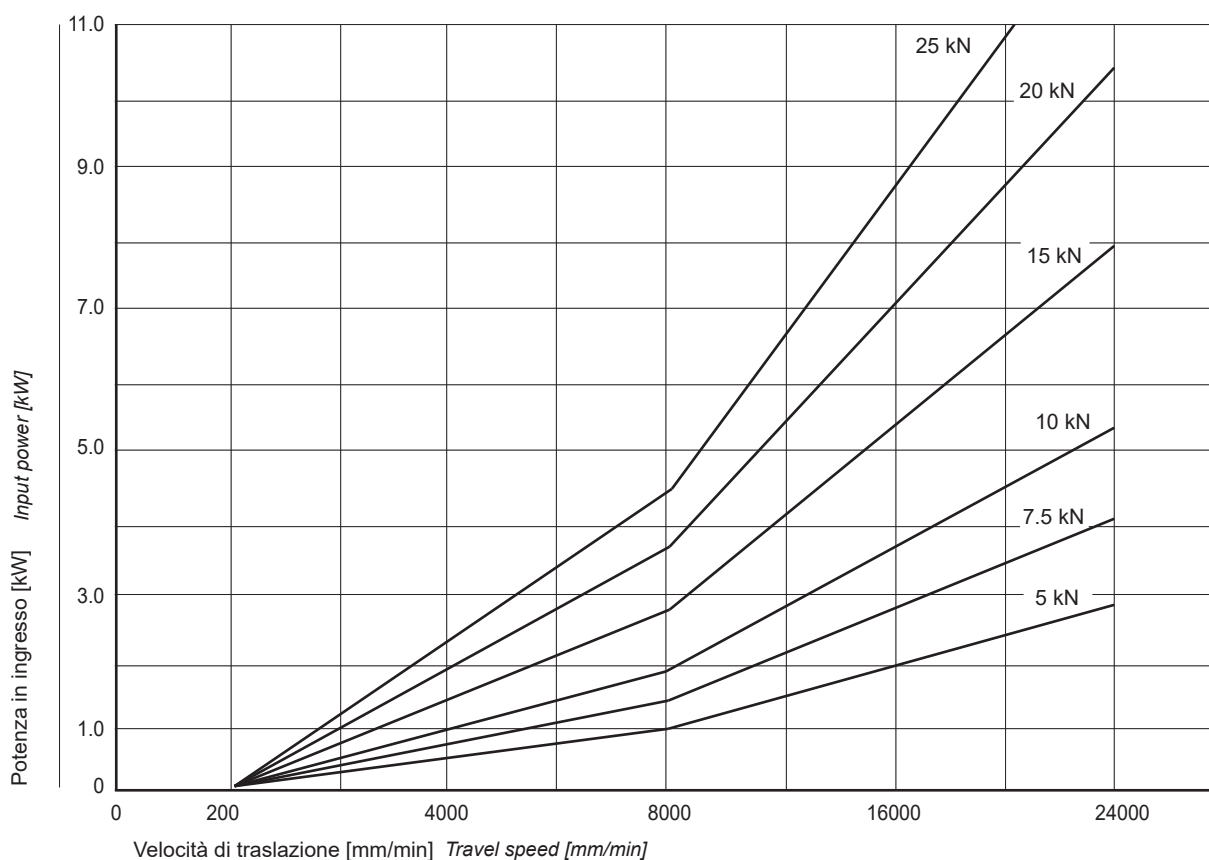



## HS/HST/HSR 100

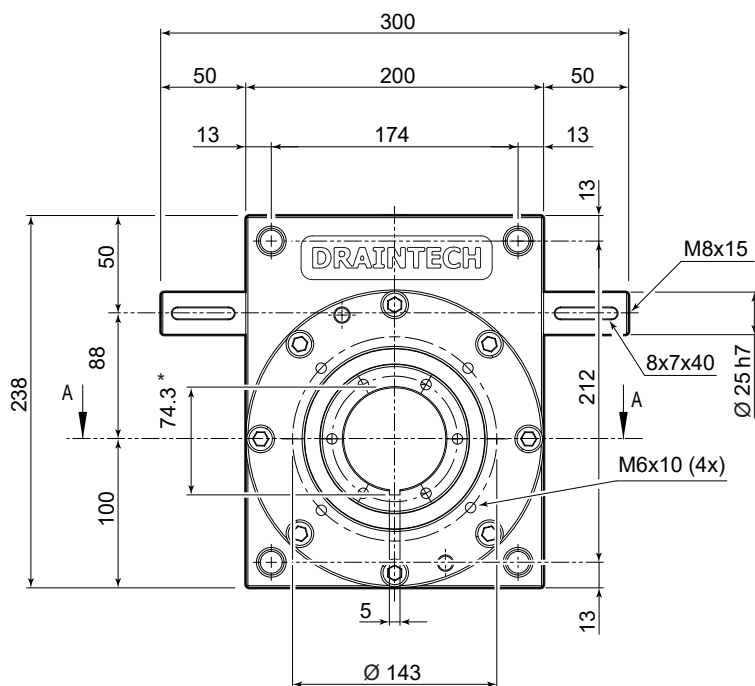
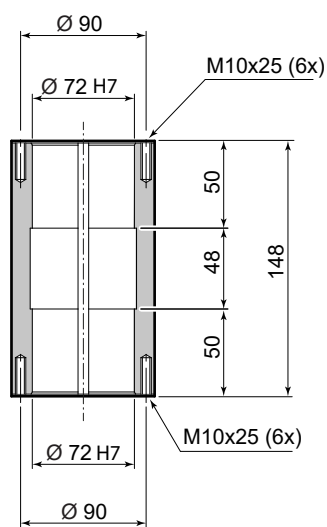
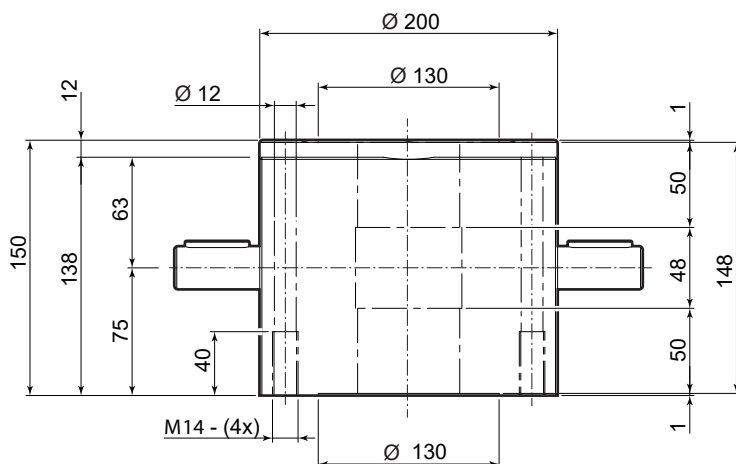
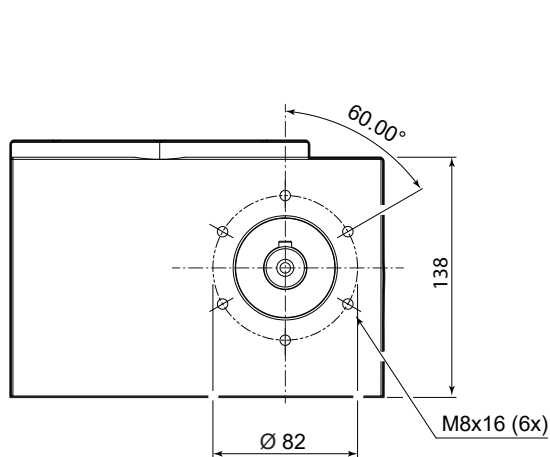

\* lavorazione sede linguetta eseguita a richiesta  
*tab seat machining carried out on request*



## HS/HST/HSR 120

Velocità in ingresso Input speed	$n_1$ [rpm]	3000	2500	2000	1500	1000	800
Velocità in uscita Output speed	$n_2$ [rpm]	600	500	400	300	200	160
Coppia in ingresso Input torque	$M_1$ [Nm]	51.0	58.2	67.7	80.0	100.0	110.0
Rendimento riduzione Reduction efficiency	[%]	0.87	0.87	0.87	0.87	0.87	0.87
Coppia in uscita Output torque	$M_2$ [Nm]	221.9	253.0	294.5	348.0	435.0	478.5
Potenza massima in ingresso Maximum input power	$P_{max}$ [kW]	16.0	15.2	14.2	12.6	10.5	9.2

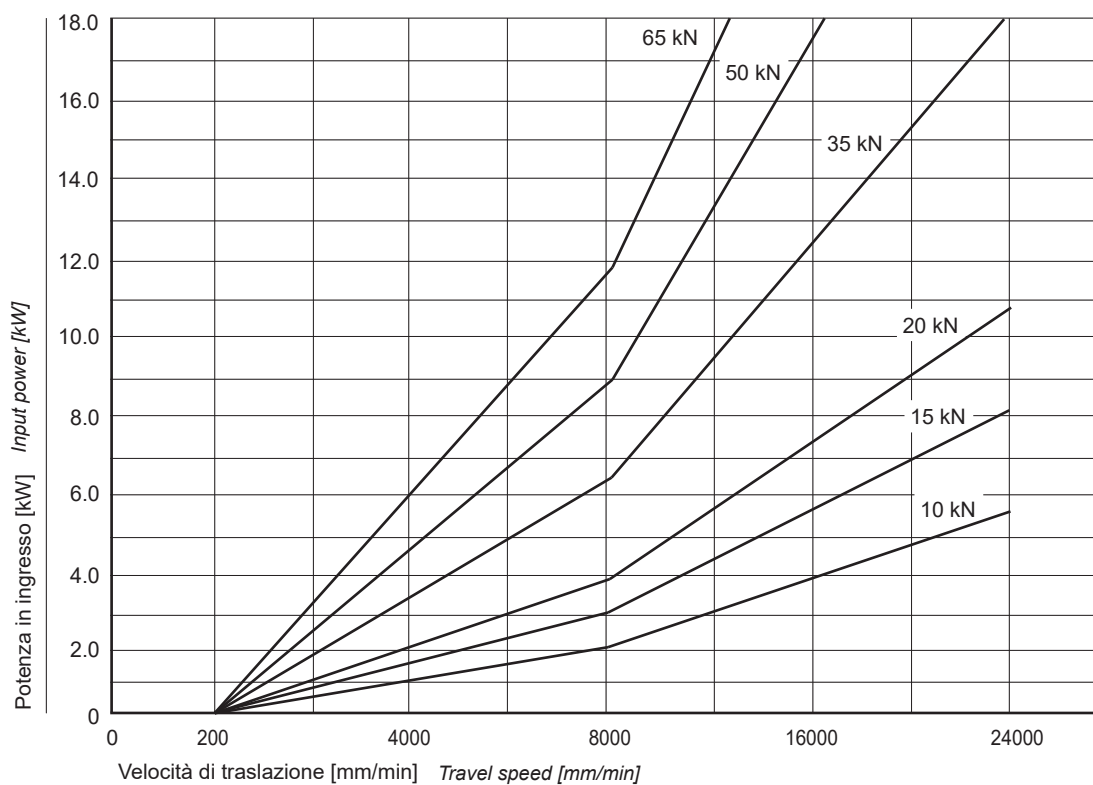



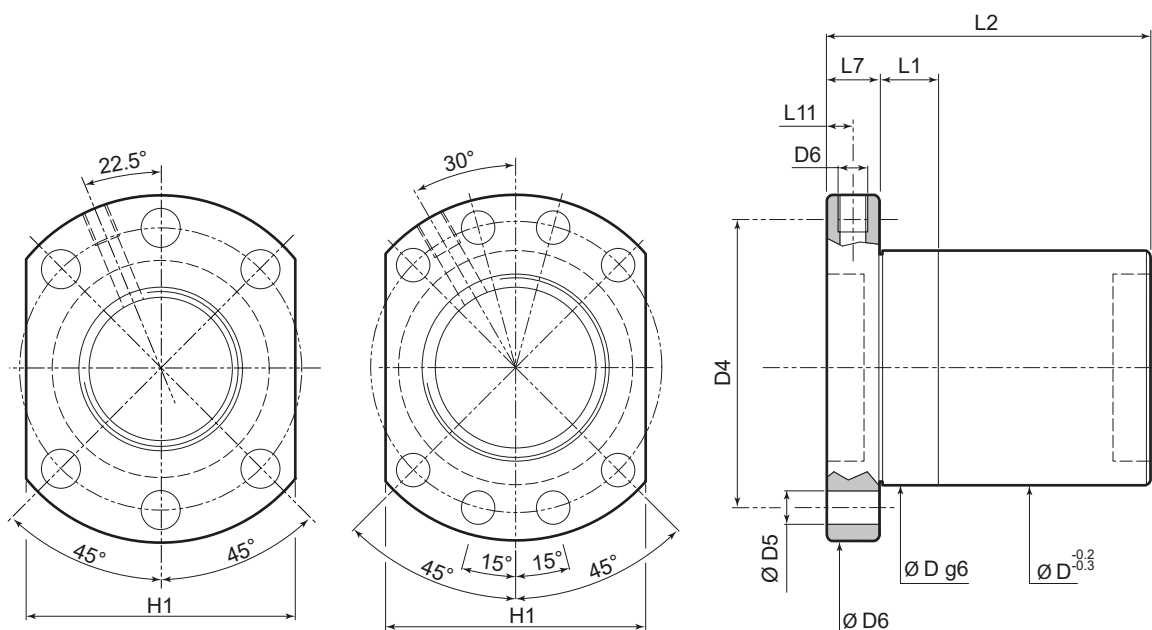





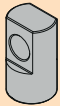
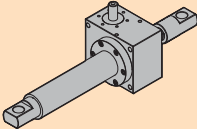
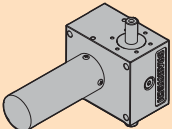

Dimensione vite Screw size		Sfera Ball	Giri di sfere Ball revs	Coeff. di carico dinamico Dynamic load coeff.	Coeff. di carico statico Static load coeff.	Chiocciola Nut			Flangia Flange								
Diametro Diameter	Passo Pitch			C	C0	D (g6)	L1	L2	Type Tipo	H1	D6	L7	D4	D5	L11	D6	
				[kgf]	[kgf]	[mm]				[mm]							
16	5	3.175	3	664	1195	28	10	40	1	40	48	10	38	5.5	5	M6x1P	
16	10	3.175	3	623	1102	28	10	60		40	48	10	38	5.5	5	M6x1P	
20	5	3.175	4	938	1993	36	10	52		44	58	10	47	6.6	5	M6x1P	
20	10	4.763	3	1149	2042	36	10	60		44	58	10	47	6.6	5	M6x1P	
25	5	3.175	4	1127	2776	40	12	52		48	62	10	51	6.6	5	M6x1P	
25	10	4.763	3	1430	2913	40	16	65		48	62	10	51	6.6	5	M6x1P	
32	10	6.35	6	4109	9606	50	12	110		62	80	12	65	9	6	M6x1P	
32	5	3.175	4	1291	3696	50	10	53		62	80	12	65	9	6	M6x1P	
40	10	6.35	4	3396	8488	62	16	87		2	70	93	14	78	9	7	M8x1P
40	10	6.35	4	3396	8488	63	16	87			70	93	14	78	9	7	M8x1P
40	10	6.35	6	4812	12732	63	16	108	70		93	14	78	9	7	M8x1P	
40	5	3.175	4	1414	4621	63	10	53	70		93	14	78	9	7	M8x1P	
40	5	3.175	6	2990	11650	63	10	66	70		93	14	78	9	7	M8x1P	
50	10	6.35	4	3899	11112	75	16	89	85		110	16	93	11	8	M8x1P	
50	5	3.175	6	2213	8909	75	10	70	85		110	16	93	11	8	M8x1P	
50	20	9.525	4	8309	21608	75	16	149	85		110	16	93	11	8	M8x1P	
63	20	9.525	5	11536	35194	95	25	175	100		135	20	115	13.5	10	M8x1P	

Per chiocciolate di forme o passi diversi, contattare il nostro Ufficio Tecnico / For nuts of different shapes or pitches, please contact our Technical Department

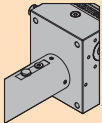
**Screw  
Jacks**

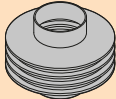
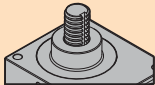
**Accessori**  
**Accessories**

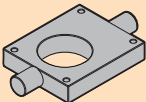
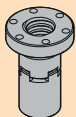
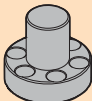
Accessori Accessories		Descrizione Description	Utilizzabile sul modello Can be used on the model				Pagina Page
			DHT		HS		
			Traslante Translating	Rotante Rotating	Traslante Translating	Rotante Rotating	
	vedi pag. see p.	Terminali Terminals	●	●	●	●	D4
	PO	Protezione rigida oscillante Oscillating rigid protection	●	-	●	-	D6
	PR	Protezione rigida Rigid protection	●	-	●	-	D7
	NG	Ingrassatore Greaser	●	-	●	-	D8
	PRO	Protezione rigida a bagno d'olio Oil-bath rigid protection	●	-	●	-	D9
	AS	Boccola antisfilamento Anti-disengagement bushing	●	-	●	-	D10
	PE	Protezione elastica Elastic protection	●	●	●	●	D11
	AR	Antirrotazione ad asta scanalata Grooved anti-rotation rod	●	-	-	-	D15
	ARD	Antorotazione a doppia guida Double-guided anti-rotation	●	-	●	-	D16
	FCO	Flangia per cassa oscillante Flange for oscillating casing	●	●	-	-	D17
	CSU	Chiocciola di sicurezza e controllo usura Safety and wear control nut	●	●	-	-	D18
	PL	Perni laterali Side pins	●	●	●	●	D19

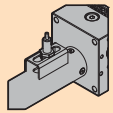
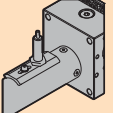
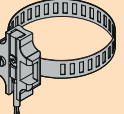
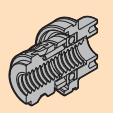
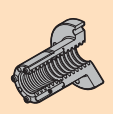
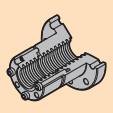
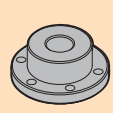
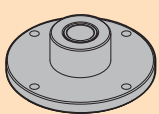
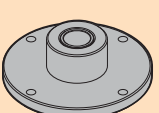
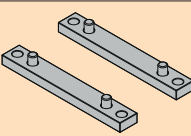
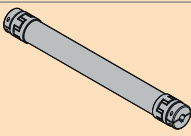
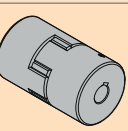
Accessori Accessories		Descrizione Description	Utilizzabile sul modello Can be used on the model				Pagina Page
			DHT		HS		
			Traslante Translating	Rotante Rotating	Traslante Translating	Rotante Rotating	
	FCP	Predisposizione fine corsa End-stop set-up	●	-	●	-	D20
	FC	Predisposizione fine corsa End-stop set-up	●	-	●	-	D21
	MLS	Fine corsa magnetici Magnetic limit switches	●	-	●	-	D22
	RGT	Recupero gioco Backlash recovery	●	-	-	-	D23
	RGR	Recupero gioco Backlash recovery	-	●	-	-	D24
	RGR BIG	Recupero gioco Backlash recovery	-	●	-	-	D25
	GR	Guida rotante Rotating guide	-	-	-	●	D26
	GSS	Guida statica superiore Upper static guide	-	-	-	●	D26
	GSI	Guida statica inferiore Lower static guide	-	-	-	●	D27
	SP	Piastre supplementari Additional plates	-	-	●	●	D28
	TS	Alberi di trasmissione Drive shafts	●	●	●	●	D29
	GR	Giunti Couplings	●	●	●	●	D31

## Terminali

## Terminals

E' disponibile una serie completa di terminali da applicare alla vite trapezia per permettere il miglior accoppiamento possibile con le macchine sulle quali sono installati i martinetti Drain-tech.

Oltre agli standard sotto elencati sono possibili personalizzazioni a richiesta sia delle aste TPN sia partendo dai terminali disponibili o su terminali completamente nuovi.

A complete series of terminals is available to be applied to the trapezoidal screw to allow the best possible coupling with the machines on which Draintech screw screw jacks are installed.

In addition to the standards listed below, customisations are possible on request either from the available TPN rods or on completely new terminals.

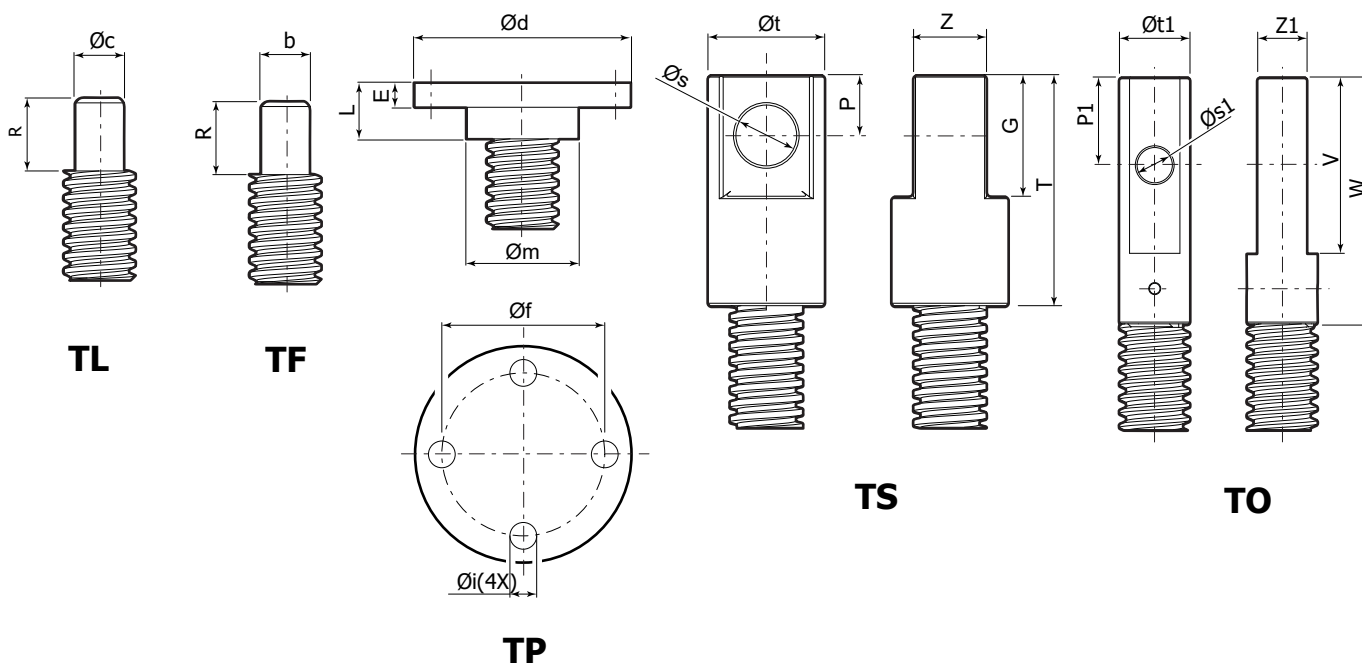

Dimensioni terminali / Terminal dimensions [mm]																					
Taglia Size	R	b	L	E	P	P1	G	T	V	W	Z	Z1	Øc	Ød	Øf	Øi	Øm	Øs	Øs1	Øt	Øt1
DHT													H					H9	H9		
183	20	M12 x 1.5	14	8	20	-	40	70	-	-	20	-	12	54	40	7	26	16	-	30	-
184	20	M12 x 1.5	14	8	20	-	40	70	-	-	20	-	12	54	40	7	26	16	-	30	-
204	20	M14 x 1.5	21	8	20	25	40	75	50	70	25	14	15	79	60	11	39	20	10	38	20
306	30	M20x2.5	23	10	25	30	50	95	60	80	30	20	20	89	67	11	46	25	14	48	30
407	30	M30 x 3.5	30	15	35	40	70	125	80	100	40	30	30	109	85	13	60	35	22	68	40
559	50	M36 x 4	50	20	50	40	100	180	80	100	60	42	40	149	117	17	85	50	30	88	55
609	50	M36 x 4	50	20	50	40	100	180	80	100	60	42	40	149	117	17	85	50	30	88	60
7010	60	M56 x 5.5	60	30	60	50	120	210	100	120	75	55	55	198	155	25	105	60	40	108	70
8010	60	M64 x 6	60	30	65	55	130	225	11	130	80	65	65	218	170	25	120	65	45	118	80
9010	60	M64 x 6	60	30	65	55	130	225	11	130	80	65	65	218	170	25	120	65	45	118	80
12014	150	M90 x 6	80	50	100	-	200	350	-	-	120	-	100	298	240	32 (*)	170	100	-	118	-
16016	125	M125X6	100	60	-	-	-	-	-	-	-	-	140	378	300	52(*)	210	-	-	-	-

Per versione HS contattare Ufficio Tecnico / For HS version contact the Technical Department

Terminali

Terminals

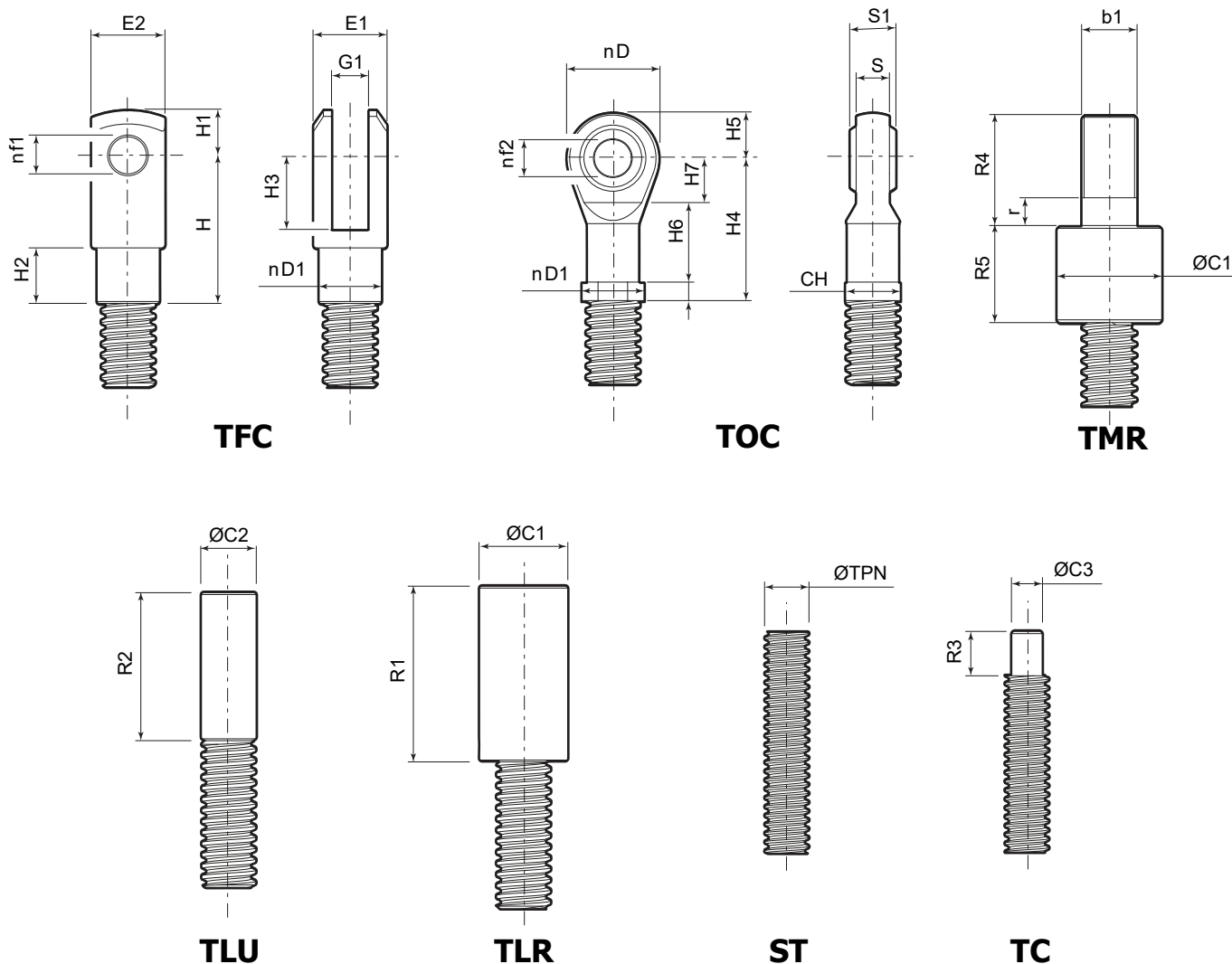

Dimensioni terminali / Terminal dimensions [mm]																													
Taglia Size	Øc2	Øc1	b1	Øc3	R5	R4	r	R1	R3	R2	Ch	ØD	ØD1	E2	Øf1	Øf2	G1	H	H1	H2	S	S1	H3	H4	H5	H6	H7	E1	ØTPN
DHT				h7																									
183	-	-	-	12	-	-	-	-	14	-	-	-	-	-	-	-	-	-	-	-	-	-	-	-	-	-	-	-	18
184	-	-	-	12	-	-	-	-	14	-	-	-	-	-	-	-	-	-	-	-	-	-	-	-	-	-	-	-	18
204	20	38	M20X1.5	15	35	40	10	75	20	70	19	32	22	24	12	12	12	48	14	18	12	16	24	50	16	6.5	17	24	20
306	30	48	M30X2	20	45	50	10	95	25	80	30	50	34	40	20	20	20	80	25	30	18	25	40	77	25	10	27	40	30
407	40	68	M39X3	25	55	70	10	125	30	100	41	70	50	55	30	30	30	110	38	38	25	37	54	110	35	15	36	55	40
559	55	88	M56X4	40	80	90	20	180	45	100	50	80	58	70	35	35	35	144	44	40	28	43	72	125	40	17	41	70	55
609	60	88	M56X4	40	80	90	20	180	45	100	50	80	58	70	35	35	35	144	44	40	28	43	72	125	40	17	41	70	60
7010	70	108	M72X4	55	90	105	25	210	70	120	-	-	-	-	-	-	-	-	-	-	-	-	-	-	-	-	-	-	70
8010	80	118	M80X4	60	95	110	25	225	75	130	-	-	-	-	-	-	-	-	-	-	-	-	-	-	-	-	-	-	80
9010	90	138	M100X4	70	120	120	30	280	80	-	-	-	-	-	-	-	-	-	-	-	-	-	-	-	-	-	-	-	90
12014	120	168	M120X4	90	150	130	30	350	85	-	-	-	-	-	-	-	-	-	-	-	-	-	-	-	-	-	-	-	120
16016	-	216	M150X4	130	180	180	35	380	120	-	-	-	-	-	-	-	-	-	-	0	-	-	-	-	-	-	-	-	160X16

Per versione HS contattare Ufficio Tecnico / For HS version contact the Technical Department

## PO protezione rigida oscillante

Per le versioni traslanti sono possibili montaggi basculanti realizzati tramite i nostri terminali tipo PO.

Questo terminale, oltre a contenere la vite TPN o la vite a ricircolo di sfere, ha la funzione di sostenere completamente il carico applicato.

Nel caso di corse di lavoro molto lunghe, vi chiediamo di contattare il nostro ufficio tecnico in modo da evitare flessioni anomale per rapporto alle taglie selezionate.

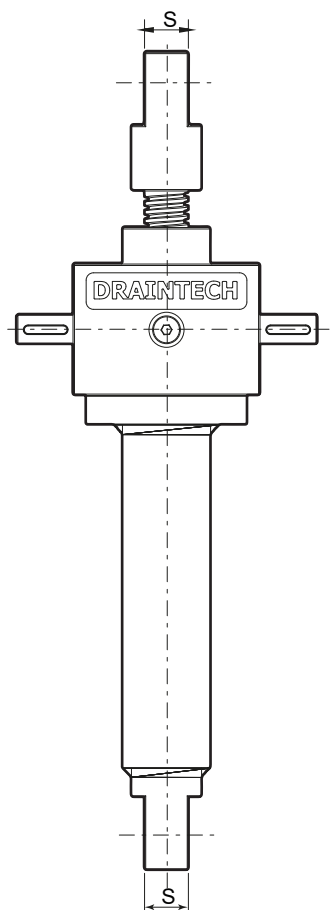
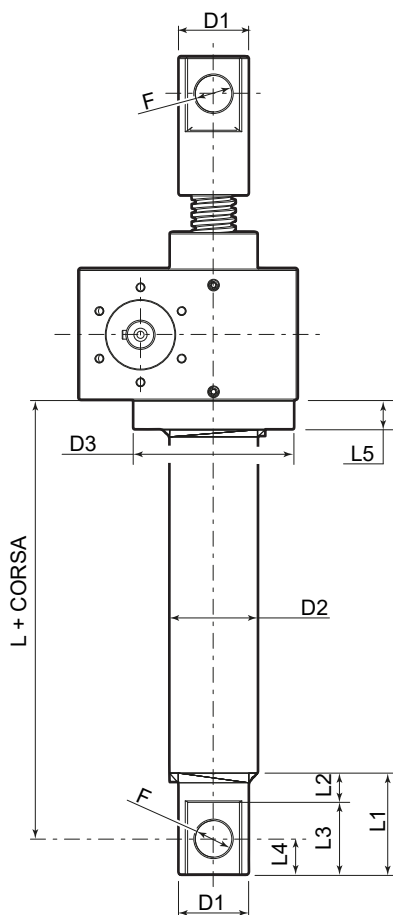

## PO oscillating rigid protection

For translating versions, tilting mounts are possible using our PO-type terminals.

This terminal, in addition to holding the TPN screw or ball screw, has the function of fully supporting the applied load.

In the case of very long working strokes, we would ask you to contact our technical department in order to avoid abnormal bending in relation to the selected sizes.

		Dimensioni / Dimensions [mm]											
Taglia Size	DHT	ØD1	ØD2	ØD3	ØF	L	L1	L2	L3	L4	L5	S	
					H8								
204		38	45	76	20	90	55	15	40	20	15	25	
306		48	60	110	25	115	70	20	50	25	20	30	
407		68	85	150	35	145	95	25	70	35	20	40	
559		88	105	150	50	180	140	40	100	50	20	60	
609		88	105	150	50	180	140	40	100	50	20	30	
7010		118	133	200	60	215	175	45	130	65	25	80	
8010		118	133	200	60	215	175	45	130	65	25	80	

		Dimensioni / Dimensions [mm]											
Taglia Size	HS	ØD1	ØD2	ØD3	ØF	L	L1	L2	L3	L4	L5	S	
					H8								
70		48	60	140	25	140	70	20	50	25	20	30	
100		88	105	200	50	210	140	40	100	50	20	60	
120		118	133	239	65	240	175	45	130	65	25	80	

**PR**  
protezione rigida

La protezione rigida viene installata nella parte posteriore del martinetto ed è la soluzione ideale per proteggere l'asta filettata dal contatto con impurità e corpi estranei che potrebbero danneggiare l'accoppiamento.

Ovviamente questa protezione rende l'intero sistema e la macchina sul quale è installato più "pulito" esteticamente e sicura per gli operatori, eliminando il contatto accidentale con parti mobili in grado di causare infortuni anche gravi all'uomo.

Nella tabella sottostante sono indicate le dimensioni di ingombro.

**PR**  
rigid protection

*The rigid protection is installed at the rear of the screw jack and is the ideal solution to protect the threaded rod from contact with impurities and foreign bodies that could damage the coupling.*

*Obviously, this protection makes the entire system and the machine on which it is installed aesthetically 'cleaner' and safer for operators, eliminating accidental contact with moving parts that can cause even serious injuries to humans.*

*The table below shows the overall dimensions.*

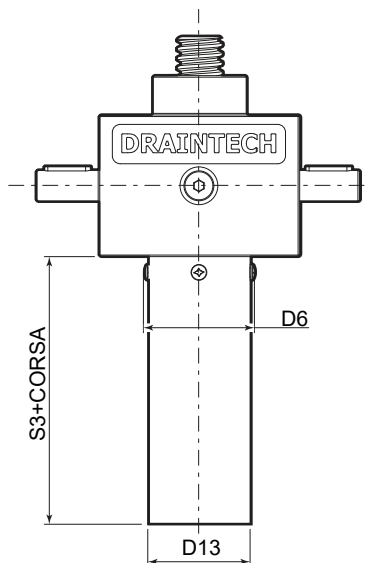

Dimensioni / Dimensions [mm]				
Taglia Size	DHT	ØD6	ØD13	S3
183	45	38	38	30
184	45	38	38	30
204	57	50	50	50
306	75	65	65	60
407	86	75	75	75
559	110	95	95	80
609	110	95	95	80
7010	137	126	126	80
8010	138	127	127	80
9010	138	127	127	80
12014	-	160	160	100
16016	-	210	210	100

Dimensioni / Dimensions [mm]				
Taglia Size	HS	ØD6	ØD13	S3
70	58	50	50	30
100	73	65	65	40
120	100	90	90	40

## NG ingrassatore

A richiesta è possibile installare sul martinetto direttamente sui fondelli, superiore o posteriore, e se non possibile sulla cass del martinetto, ingrassatori tipo UNI 7663.

Questi ingrassatori iniettano il grasso direttamente sulla vite trapezoidale evitando sprechi di grasso dovuti all'applicazione manuale.

E' anche possibile, se il martinetto è in posizione difficilmente raggiungibile, spostare l'ingrassatore con apposito impianto, in zona di più facile accessori.

## NG greaser

*On request, it is possible to install grease nipples type UNI 7663 directly on the screw jack, top or rear, and if not possible on the screw jack box.*

*These grease nipples inject grease directly onto the trapezoidal screw, avoiding grease wastage due to manual application.*

*It is also possible, if the screw jack is in a position that is difficult to access, to move the grease nipple to an area that is easier to access.*

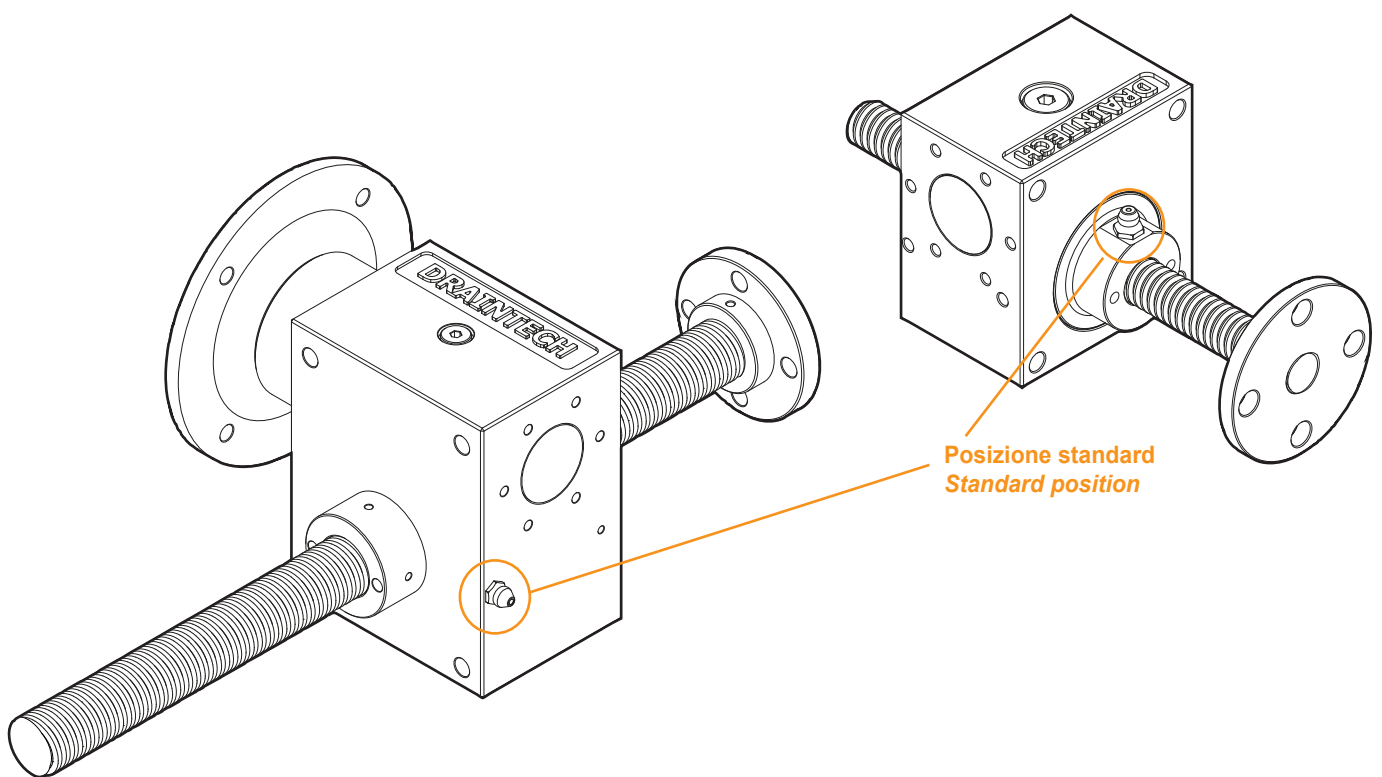

**PRO**

**protezione rigida a bagno d'olio**

La protezione rigida a bagno d'olio consente la lubrificazione semi automatica della vite trapezoidale o a ricircolo di sfere.

Ad ogni manovra, nella posizione completamente retratta, l'asta filettata si immerge nel lubrificante di cui la PRO è riempita sino al tappo di livello.

E' suggerito l'utilizzo di lubrificanti ad alta viscosità e additivati EP per estreme pressioni. Sono consentiti solo montaggi verticali o inclinati massimo di  $\pm 10^\circ$  in modo da evitare trafilamenti.

In caso di corse molto lunghe, per compensare "l'effetto pompa", è necessario applicare un tappo di sfiato che a richiesta può anche essere remotato.

**Nota:** in caso di corse molto corte, la parte di vite trapezia bagnata dal lubrificante, potrebbe non raggiungere la corona rendendo inutile questo accessorio. Contattare il nostro ufficio tecnico.

**PRO**

**oil-bath rigid protection**

The oil-bath rigid protection allows semi-automatic lubrication of the trapezoidal or ball screw.

With each manoeuvre, in the fully retracted position, the threaded rod soaks into the lubricant that PRO is filled up with to the level plug.

The use of high-viscosity, EP-added lubricants for extreme pressures is suggested. Only vertical or inclined mountings of  $\pm 10^\circ$  are permitted in order to avoid leakage.

In the case of very long strokes, in order to compensate for the 'pump effect', it is necessary to apply a relief cap, which can also be remotely controlled on request.

**Note:** In the case of very short strokes, the part of the trapezoid screw wetted by the lubricant may not reach the crown, rendering this accessory useless. Contact our technical department.

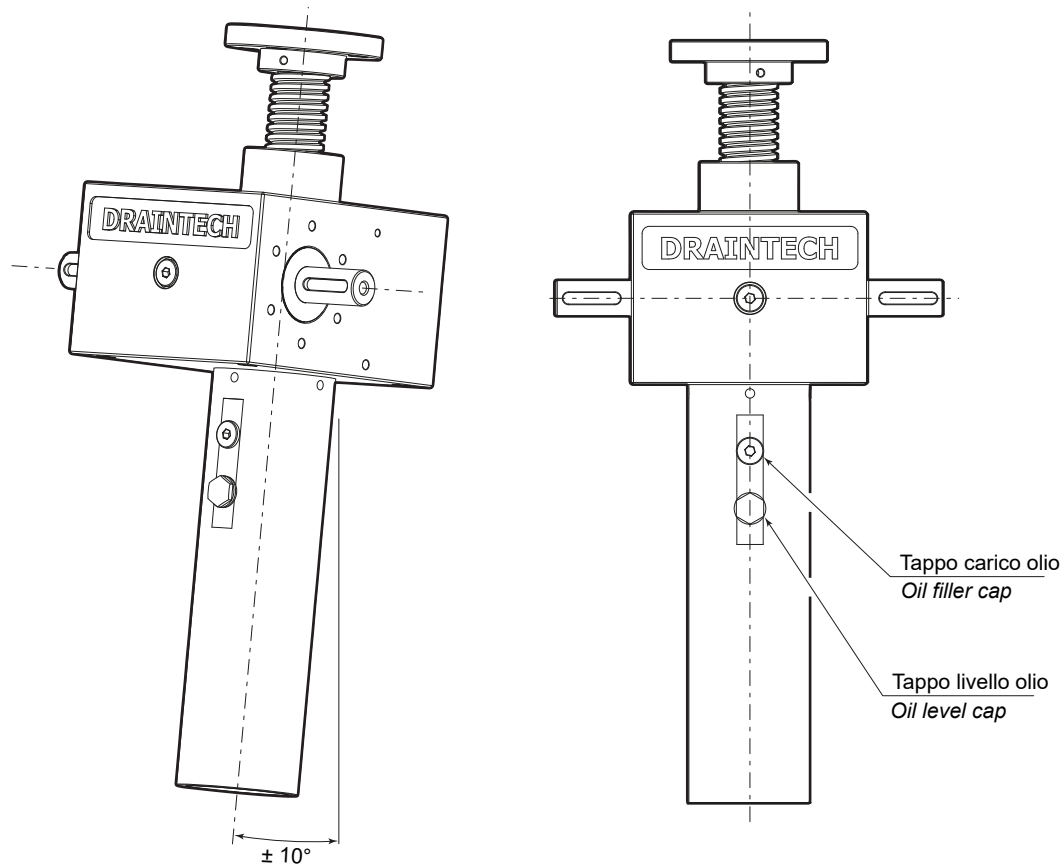

Montaggio verticale inclinazione massima ammissibile  $\pm 10^\circ$   
Vertical installation maximum permissible inclination  $\pm 10^\circ$

**AS**  
**boccola antisfilamento**

La boccola antisfilamento AS è un dispositivo di sicurezza che non permette all'asta filettata di fuoriuscire dal martinetto nel caso di extra-corsa accidentale.

Questa boccola in acciaio presenta all'interno una filettatura TPN dello stesso passo della vite e due fori filettati a 180° per il fissaggio ed il bloccaggio della boccola stessa.

Tale boccola può anche essere utilizzata come fine corsa rilevando la sua posizione in modo meccanico o con sensori di prossimità.

**AS**  
**anti-disengagement bushing**

The AS anti-disengagement bushing is a safety device that does not allow the threaded rod to slip out of the screw jack in the event of accidental overtravel.

This steel bushing has a TPN thread on the inside with the same pitch as the screw and two 180° threaded holes for fixing and locking the bushing.

This bushing can also be used as an end stop by detecting its position mechanically or with proximity sensors.

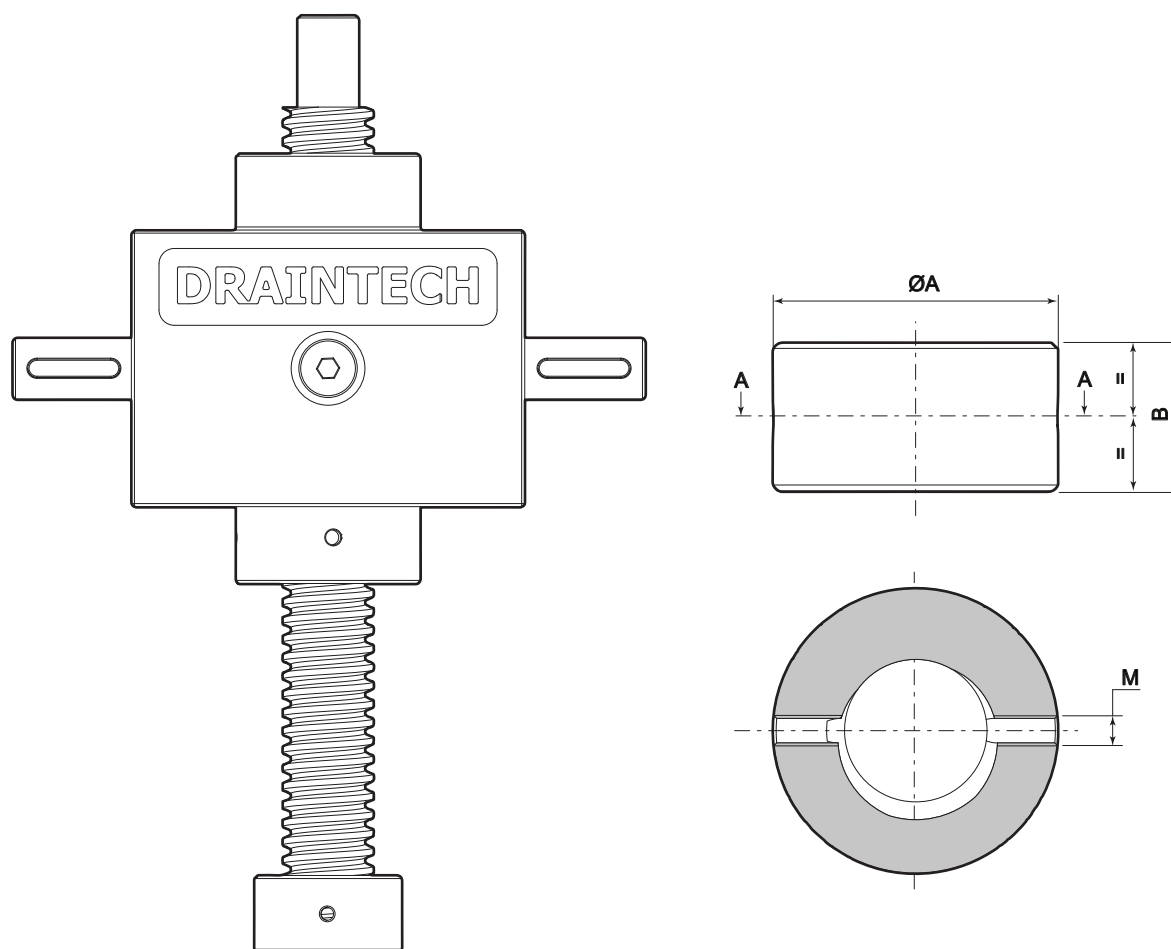

Dimensioni / Dimensions [mm]													
Taglia Size	DHT	183	184	204	306	407	559	609	7010	8010	9010	12014	16016
B		25	25	25	25	25	25	25	40	40	40	40	60
ØA		26	26	38	48	58	78	78	88	88	88	145	190
M (x2)		M4	M4	M4	M5	M6	M6	M6	M8	M8	M8	M20	M20

Per versione HS contattare Ufficio Tecnico / For HS version contact the Technical Department

**PE**  
**protezione elastica**

Le protezioni a soffietto elastiche hanno la funzione di proteggere l'asta filettata dagli agenti esterni seguendone il movimento.  
Le protezioni elastiche standard sono realizzate in tessuto nylon spalmato PVC ad anelli cuciti.  
Le protezioni sono fornibili con terminali a collari o a flangia i cui ingombri sono riportati in tabella sottostante .

Sono possibili i più svariati tipi di combinazione ed esecuzioni speciali e le flange di fissaggio possono essere in materiale plastico o metallico a richiesta.  
Sono inoltre disponibili realizzazioni in materiali speciali, come Neoprene® (resistente all'acqua marina), Kevlar® (resistente ai tagli e alle abrasioni), fibra di vetro (per temperature estreme, da -50 a 250°C) e carbonio albumizzato (materiale autoestinguente per applicazioni limite con schizzi di metallo fuso).  
Le temperature di esercizio del materiale standard (nylon spalmato PVC) è : -30 / + 70°C.

In caso di lunghe corse o di orientamento orizzontale dell'asta filettata, si possono prevedere collari distanziatori interni per prevenire il contatto tra la protezione e lo stelo stesso. Se non diversamente specificato le protezioni PE sono fornite con i collari in tessuto e le dimensioni riportate in tabella supponendo un montaggio verticale.

**PE**  
**elastic protection**

Elastic bellows protections have the function of protecting the threaded rod from external agents by following its movement.  
Standard elastic protections are made of PVC-coated nylon fabric with sewn-in rings.  
The protections can be supplied with collar or flange terminals whose dimensions are shown in the table below .

Various combinations and special executions are possible, and the fixing flanges can be made of plastic or metal on request.  
Special materials are also available, such as Neoprene®, Hypalon® (seawater resistant), Kevlar® (cut and abrasion resistant), glass fibre (for extreme temperatures from -50 to 250°C) and aluminised carbon (self-extinguishing material for borderline applications with molten metal splashes). The operating temperature of the standard material (PVC-coated nylon) is: -30 / + 70°C.

With long strokes or the horizontal orientation of the threaded rod, internal spacer collars can be provided to prevent contact between the protection and the rod itself. Unless otherwise specified, PE protections are supplied with the fabric collars and dimensions shown in the table assuming vertical configuration.

ACC.

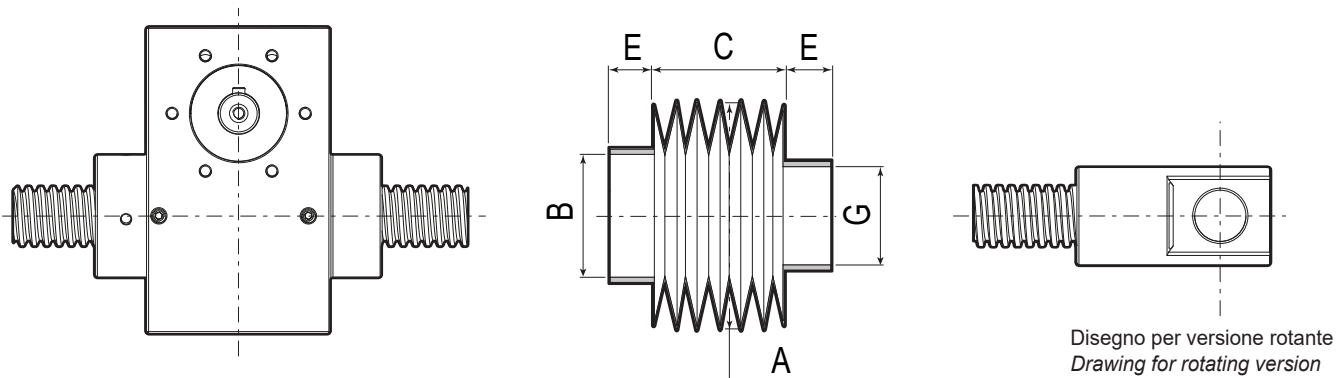

Dimensioni / Dimensions [mm]													
Taglia Size	DHT	183	184	204	306	407	559	609	7010	8010	9010	12014	16016
ØA		65	65	65	85	105	120	120	130	140	140	180	240
ØB		30	30	44	60	69	90	90	120	120	120	210	300
C		Corsa / Stroke											
E		Varia con il tipo di terminale / Varies with terminal type											
F		Varia con il tipo di terminale / Varies with terminal type											
G		Varia con il tipo di terminale / Varies with terminal type											

## PE protezione elastica

L'applicazione delle protezioni elastiche sui martinetti può comportare delle modifiche dimensionali a causa degli ingombri propri della PE, come riportato nella tabella sottostante.

In condizioni di tutto chiuso la PE ha un ingombro pari a circa 1/10 del valore della corsa.

Nel caso che tale valore sia maggiore della quota PI (rilevabile nelle tabelle dimensionali dei martinetti) è necessario adattare la lunghezza totale dell'asta filettata a tale ingombro.

## PE elastic protection

The application of elastic protections on the screw jacks may result in dimensional changes due to the PE's own dimensions, as shown in the table below.

In fully closed conditions, the PE has a footprint of about 1/10 of the stroke value.

If this value is greater than the PI dimension (provided in the dimensional tables of the screw jacks), it is necessary to adapt the total length of the threaded rod to this dimension.

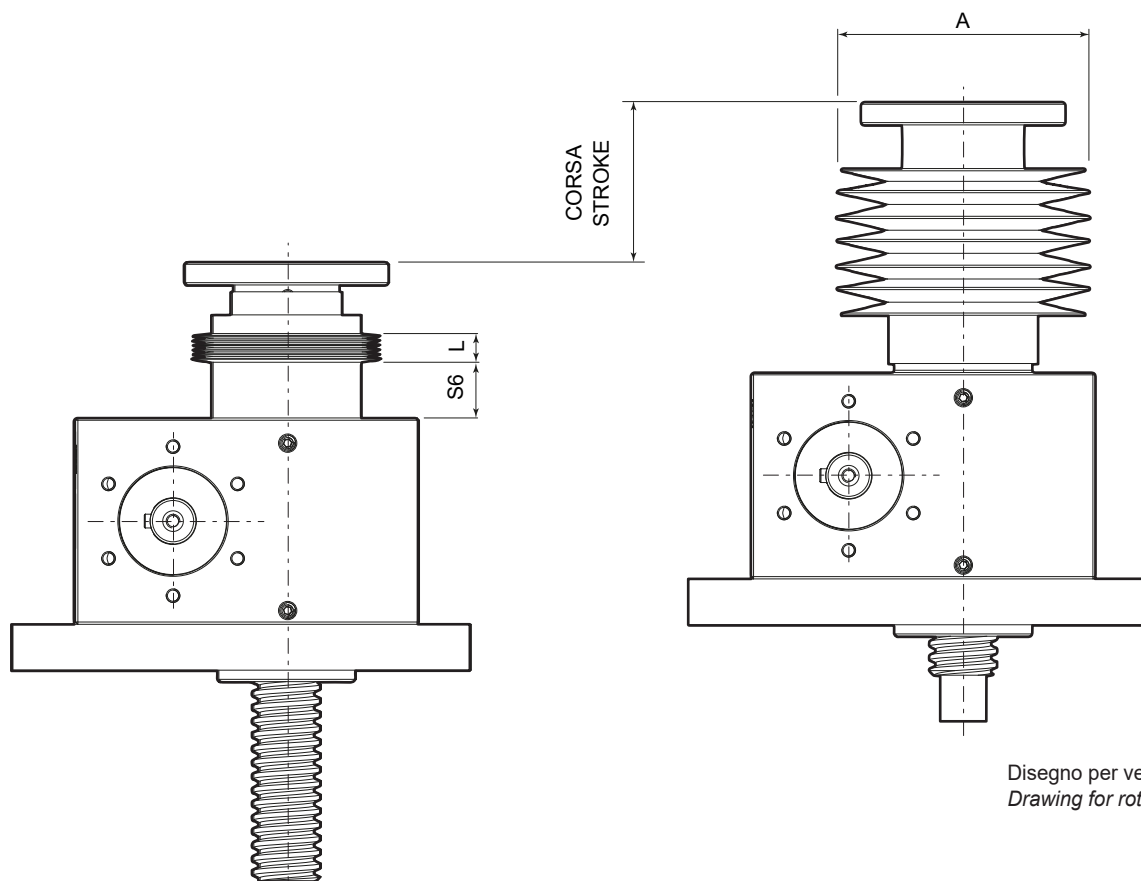

Dimensioni / Dimensions [mm]													
Taglia Size	DHT	183	184	204	306	407	559	609	7010	8010	9010	12014	16016
S6		10	10	20	25	35	40	40	40	40	40	50	60
ØA		70	70	70	80	105	120	120	130	140	140	190	230
L		1/10 della Corsa / 1/10 of the Stroke											

PE  
protezione elastica

PE  
elastic protection

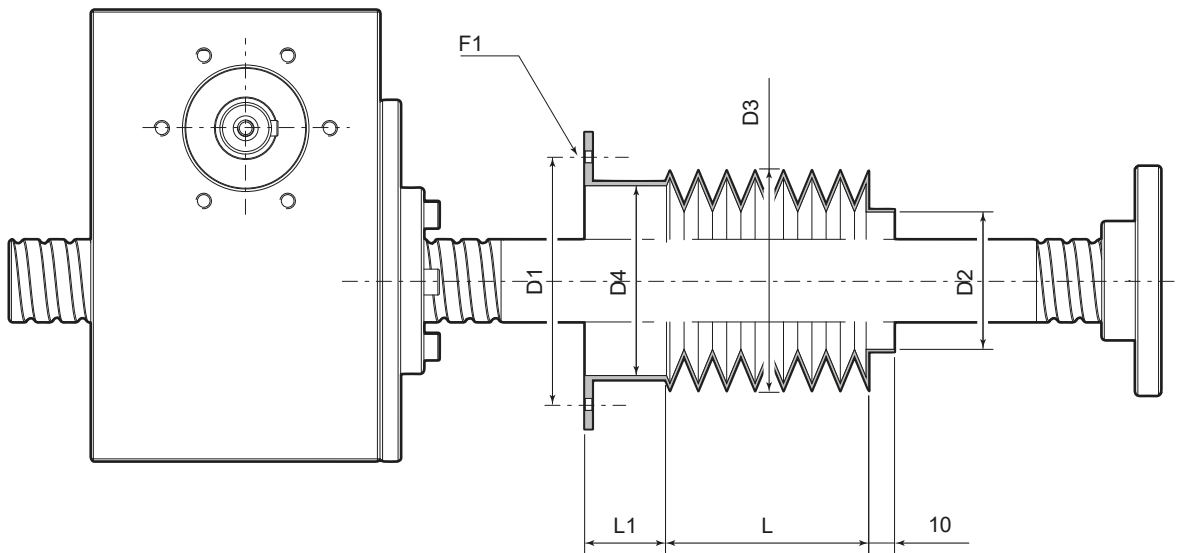
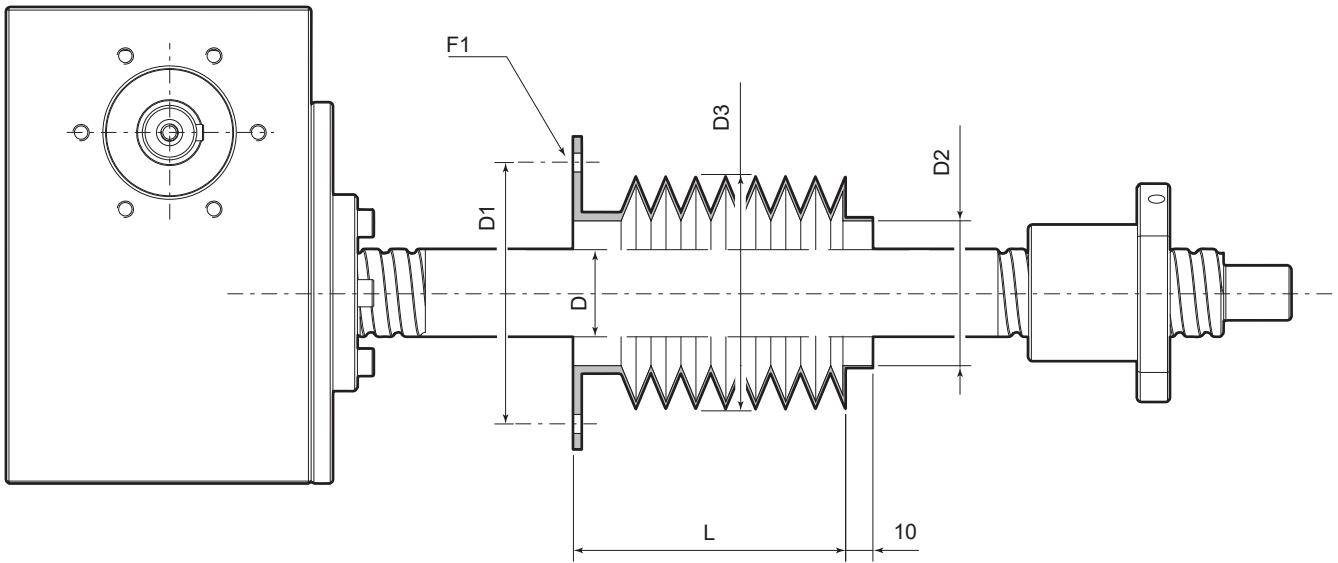

Dimensioni / Dimensions [mm]				
Taglia Size	HS	HS70	HS100	HS120
D	Diametro vite / Screw diameter			
D1		96	143	182
D2	Dimensione variabile in funzione della chiocciola da montare Variable size depending on the nut to be mounted			
D3		85	120	140
F1		7	7	7
L	Soffietto chiuso 0.125 x corsa Bellows closed 0.125 x stroke			
L1	Dimensione variabile in funzione della chiocciola da montare Variable size depending on the nut to be mounted			
D4				

**PE**  
protezione elastica

**PE**  
elastic protection

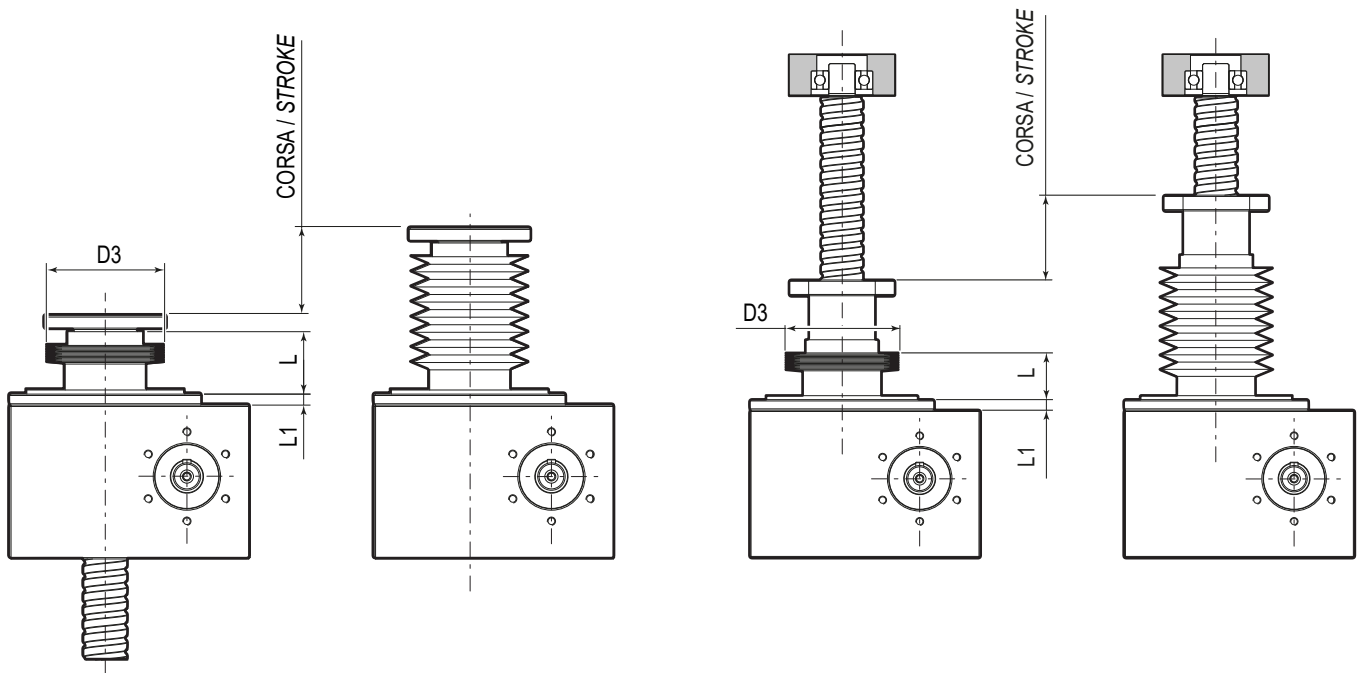

Dimensions / Dimensioni [mm]				
Taglia Size	HS	HS70	HS100	HS120
L	Soffietto chiuso 0.125 x corsa Bellows closed 0.125 x stroke			
L1		8	12	15
D		85	120	140

**AR**  
**antirotazione ad asta scanalata**

Poichè tutti i martinetti devono avere un contrasto alla rotazione, qualora non sia possibile realizzare tale contrasto esternamente al martinetto, sono disponibili due sistemi di antirotazione.

Tipo AR Antirotazione ad asta scanalata.

Consiste nella realizzazione di una sede per linguetta longitudinale all'asta TPN e all'inserimento di un dispositivo antirotante all'interno del martinetto.

Per questo tipo di antirotazione, dato che la sede per linguetta ricavata sull'asta TPN interrompe i filetti e indebolisce la resistenza meccanica dell'asta stessa, è consigliabile considerare una riduzione della capacità di carico del martinetto come da tabella sottostante.

**AR**  
**anti-rotation with grooved rod**

Since all screw screw jacks must have a rotation contrast, two anti-rotation systems are available if such a contrast cannot be realised externally on the screw screw jack.

Type AR Anti-rotation with grooved rod

It consists of the creation of a tab seat longitudinal to the TPN rod and the insertion of an anti-rotation device inside the screw jack. For this type of anti-rotation, since the tab seat on the TPN rod breaks the threads and weakens the mechanical strength of the rod itself, it is advisable to consider a reduction in the load capacity of the screw jack as per the table below.

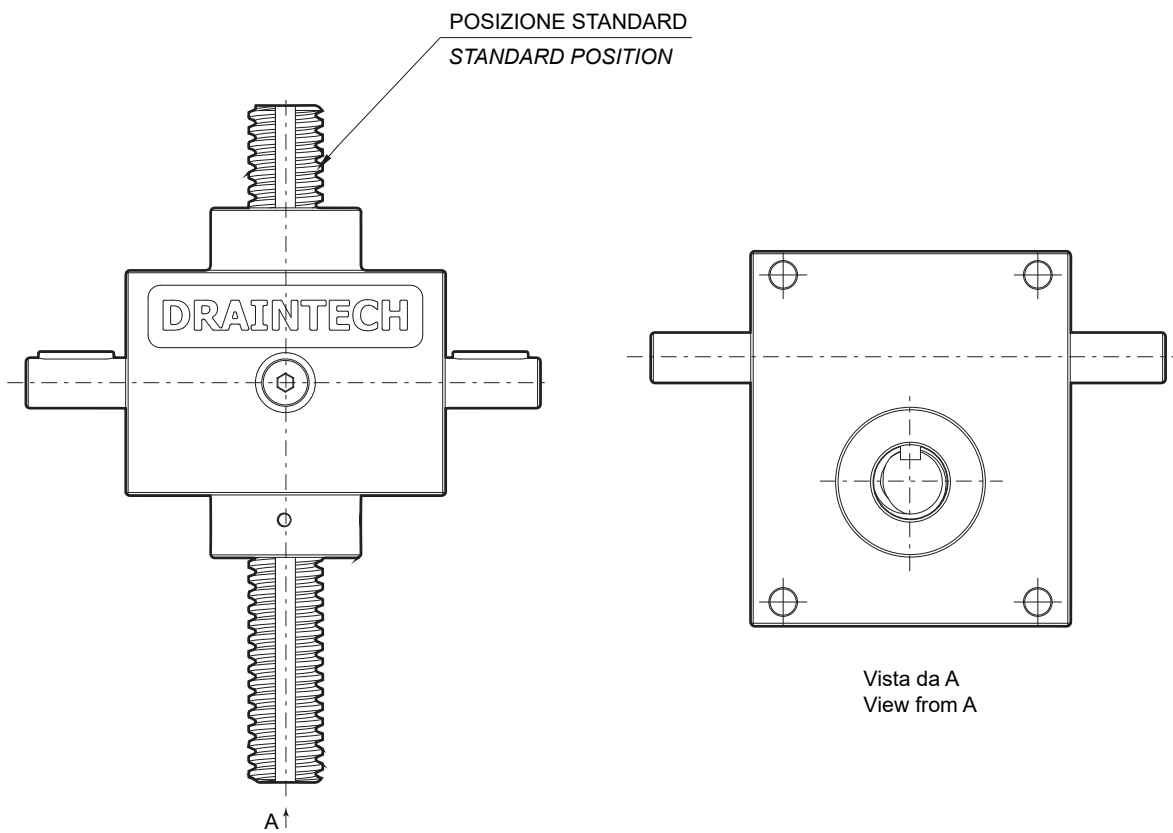

		Riduzione % del carico / Load reduction %									
Taglia / Size	DHT	204	306	407	559	609	7010	8010	9010	12014	16016
Statico / Static		15	10	10	9	9	9	9	9	5	5
Dinamico / Dynamic		40	25	25	25	25	25	25	25	15	15

## ARD antirotazione a doppia guida

TIPO ARD Antirotazione a doppia guida.

Tale sistema unisce i vantaggi di un dispositivo antirotazione esterno al martinetto e una protezione di sicurezza del dispositivo e dell' asta TPN stessa, inglobando il sistema all'interno di una protezione rigida.

Su tale protezione rigida sono montate due guide su cui scorre una bussola in acciaio resa solidale all' asta filettata.

Per le taglie DHT 183, 184, 204 e 306 e la serie HS l'antirotazione è realizzata con un inserto sagomato posto all'interno del tubo in alluminio.

## ARD double-guided anti-rotation

ARD TYPE Double-guided anti-rotation.

This system combines the advantages of an anti-rotation device outside the screw jack and a safety protection of the device and the TPN rod itself, incorporating the system within a rigid protection.

Mounted on this rigid protection are two guides on which a steel bushing slides, made integral with the threaded rod.

For the sizes DHT 183, 184, 204 and 306 and HS series, the anti-rotation is realised with a shaped insert inside the aluminium tube.

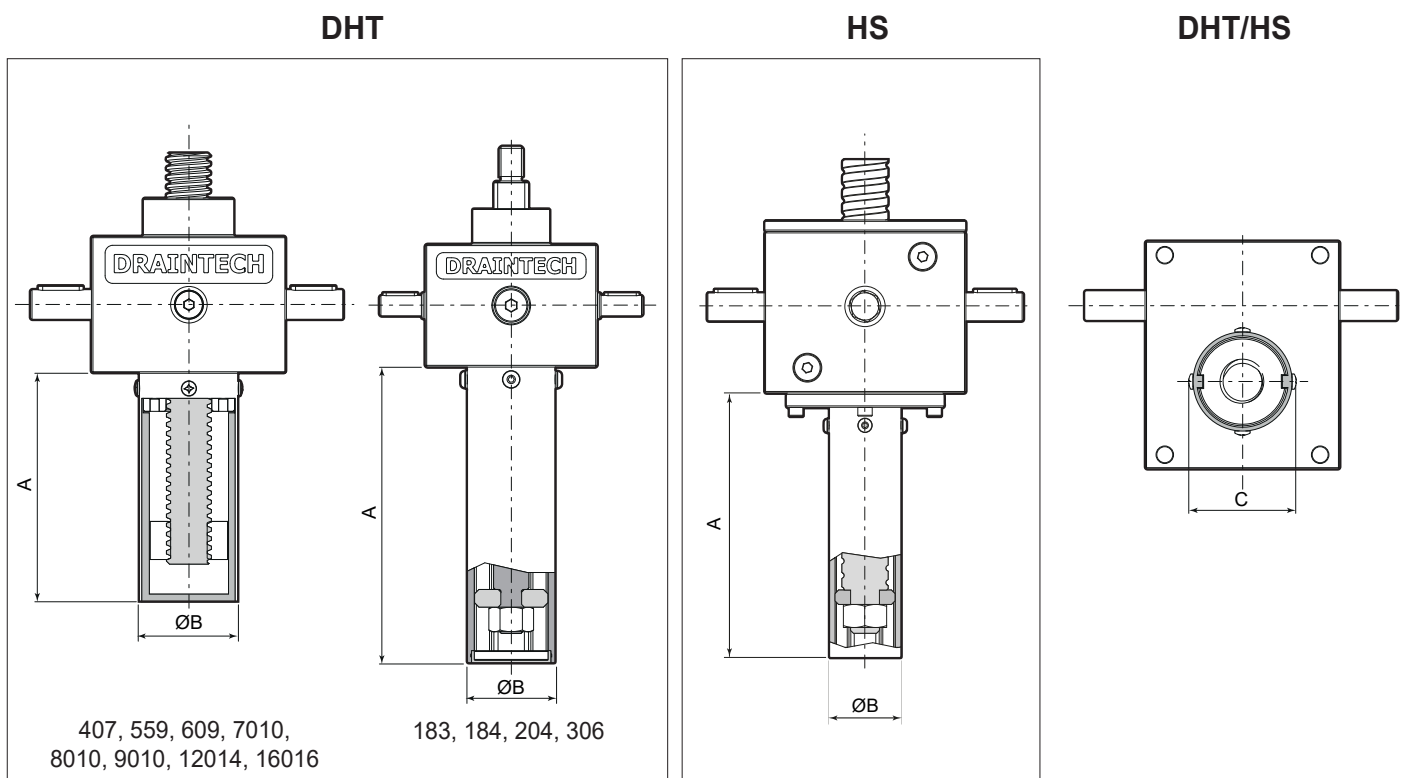

Dimensioni / Dimensions [mm]													
Taglia Size	DHT	183	184	204	306	407	559	609	7010	8010	9010	12014	16016
A		50	50	80	80	100	105	105	120	120	120	170	170
B		38	38	50	65	74	97	97	127	127	127	160	210
C		57	57	57	71	80	104	109	134	134	134	210	300

Dimensioni / Dimensions [mm]				
Taglia Size	HS	70	100	120
A		60	80	100
B		50	65	90
C		58	72.5	100

**FCO**

**flangia per casse oscillanti**

Qualora fosse necessario il montaggio basculante del martinetto abbiamo sviluppato un supporto oscillante da fissare alla cassa del martinetto stesso.

La flangia per cassa oscillante consente un utilizzo del martinetto molto simile alla versione PO, ma ne dimezza la distanza tra le due cerniere di fissaggio del martinetto ( distanza tra la testa ad occhiello e asse di rotazione dei perni ).

Nel caso di carichi a compressione , la verifica del carico di punta va fatta applicando il caso Eulero 2 su una lunghezza che è l'interasse delle cerniere .

**FCO**

**flange for oscillating casing**

*If the screw jack needs to be assembled tilted, we have developed an oscillating support to be attached to the screw jack casing.*

*The oscillating box flange allows the screw jack to be used in a very similar way to the PO version, but halves the distance between the two screw jack fastening hinges (distance between the eye head and pin rotation axis).*

*In the case of compressive loads, the verification of the peak load must be done by applying Euler 2 case on a length that is the centre distance of the hinges.*

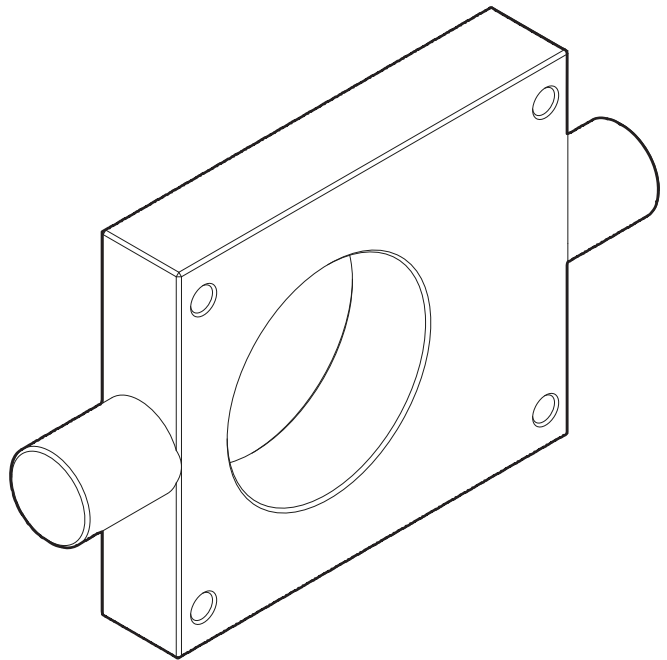
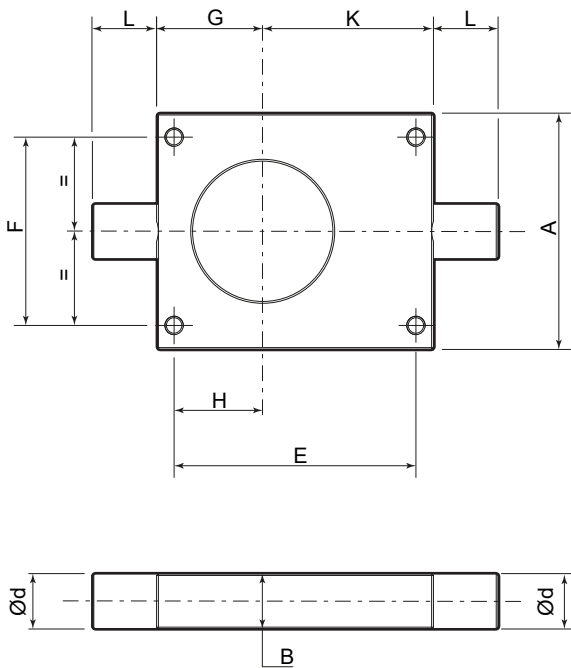

ACC.

Dimensioni / Dimensions [mm]												
Taglia Size	DHT	183	184	204	306	407	559	609	7010	8010	9010	12014
B		20	20	25	30	40	50	50	55	60	60	Fornibile su specifica cliente Can be supplied to customer speci- fication
Ød (h7) k7		15	15	25	30	40	50	50	55	60	60	
D		44	44	58	76	85	110	110	135	135	135	
H		28	28	30	48	60	60	60	90	90	90	
E		80	80	85	131	165	175	175	230	230	230	
F		56	56	80	102	130	134	134	180	180	180	
A		72	72	98	128	165	175	175	230	230	230	
G		36	36	38.5	57.5	75	78	78	115	115	115	
K		60	60	63.5	92.5	125	138	138	135	135	135	
L		20	20	25	30	40	50	50	60	60	60	

## CSU

### chiocciola di sicurezza e controllo dell'usura

Molte applicazioni richiedono che il martinetto sia in grado di sostenere il carico anche in condizioni di usura della madrevite, intendendosi come madrevite sia la ruota elicoidale sia la chiocciola. Tale usura della madrevite può essere anche verificata e misurata tenendo sotto controllo il valore limite suggerito "S minimo", essendo esso un quarto del passo della relativa vite. Questo valore "S minimo" non è il valore al quale il martinetto sicuramente cederà, ma è il valore soglia di guardia che evidenzia una importante usura della madrevite in corso.

## CSU

### safety and wear control nut

Many applications require the screw jack to be able to support the load even when the nut is worn, meaning nut as both the helical gear and the nut. The nut wear can also be checked and measured by keeping an eye on the suggested limit value 'S minimum', it being a quarter of the pitch of the relative screw. This 'S minimum' value is not the value at which the screw jack will surely fail, but is the guard threshold value that indicates significant ongoing wear of the nut.

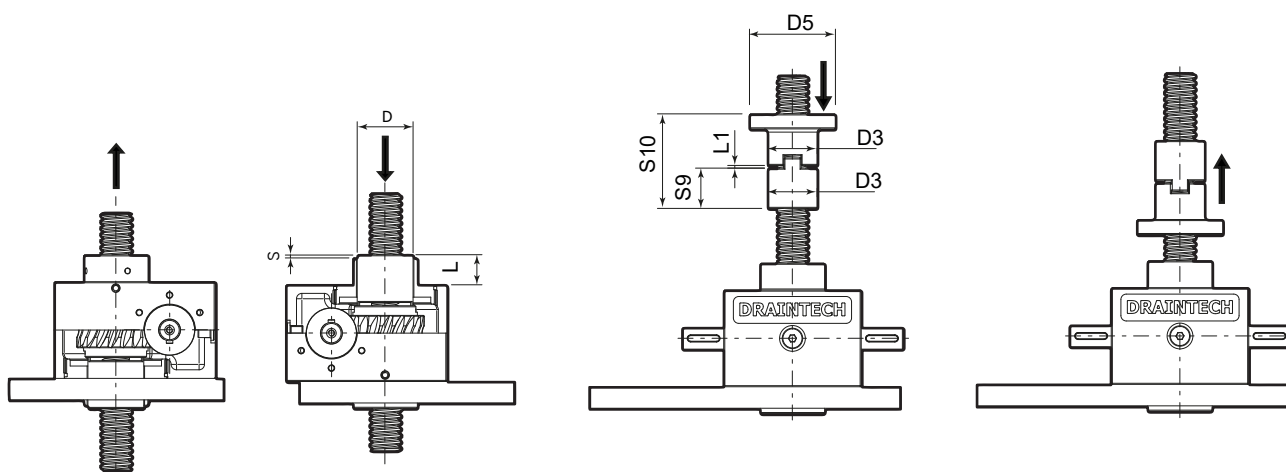

Chiocciola di sicurezza e controllo usura martinetti TRASLANTI TRANSLATING safety and wear control nut [mm]										
Taglia Size	DHT	204	306	407	559	609	7010	8010	9010	12014
ØD		40	52	58	82	82	100	110	150	170
L1		17	20	32	42	42	58	63	63	65
S *		2	3	3.5	4.5	4.5	5	5	5	7
Smin **		1	1.5	1.75	2.25	2.25	2.5	2.5	2.5	3.5

Chiocciola di sicurezza e controllo usura martinetti ROTANTI ROTARY screw jacks safety and wear nut [mm]										
Taglia Size	DHT	204	306	407	559	609	7010	8010	9010	12014
ØD3		32	46	60	76	80	100	110	150	180
ØD5		60	80	96	130	110	180	190	230	280
L1 *		2	3	3.5	4.5	4.5	5	5	5	7
Lmin **		1	1.5	1.75	2.25	2.25	2.5	2.5	2.5	3.5
S9		35	38	64	89	60	90	95	115	136
S10		82	89	142.5	193.5	165	200	210	256	302

\* valore a nuovo / value as new

\*\* valore minimo suggerito / minimum suggested value

**PL**  
perni laterali

La soluzione di montaggio con perni laterali PL consente al martinetto di poter ruotare attorno all'asse dei perni stessi. Questa soluzione, alternativa alla FCO (flangia per cassa oscillante) consente di ridurre ulteriormente la distanza tra le due cerniere nel caso venga montato in abbinamento con il terminale ad occhio.

Nella tabella sottostante sono indicate le dimensioni di ingombro a perni montati. La verifica dei carichi a compressione deve essere eseguita utilizzando le tabelle di EULERO 2 con una lunghezza ovviamente pari all'interasse tra le cerniere.

**PL**  
side pins

The PL side pin mounting solution allows the screw jack to rotate around the axis of the pins. This solution, which is an alternative to the FCO (flange for oscillating casing), allows the distance between the two hinges to be further reduced if it is mounted in conjunction with the eye terminal.

The table below shows the overall dimensions with pins fitted. Compressive loads must be verified using the tables in EULER 2 with a length obviously equal to the centre distance between the hinges.

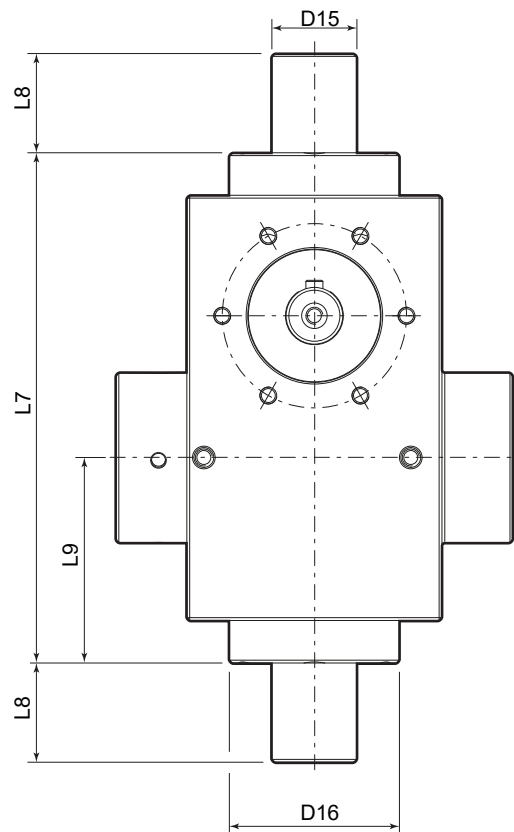
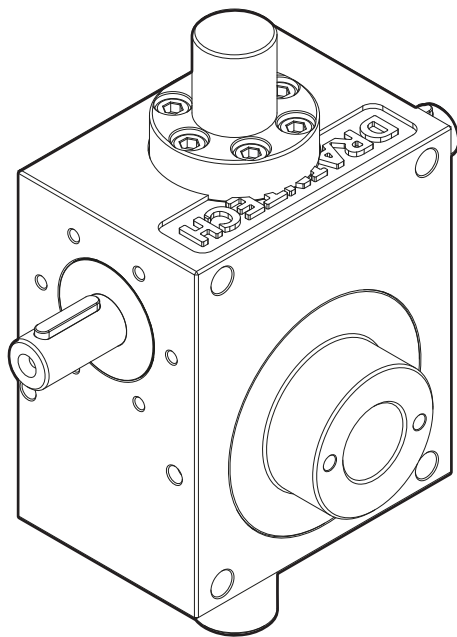

Dimensioni / Dimensions [mm]									
Taglia Size	DHT	204	306	407	559	609	7010	8010	9010
ØD15 (k6)	25	30	40	50	50	55	60	60	65
ØD16	55	60	70	80	80	95	95	100	100
L7	125	180	225	261	261	310	310	350	350
L8	30	35	45	55	55	60	60	65	65
L9	50	72,5	90	103	103	130	130	140	140

Dimensioni / Dimensions [mm]				
Taglia Size	HS	70	100	120
ØD15 (k6)	30	40	55	55
ØD16	30	70	95	95
L7	200	268	340	340
L8	35	45	60	60
L9	82.5	115	135	135

## FCP

### predisposizione per fine corsa

Per controllare elettricamente la corsa forniamo due possibili predisposizioni.

La prima, denominata FCP (predisposizione fine corsa a ponte), è lo standard comunemente utilizzato ed è basata su un ponte di lamiera saldata sulla protezione rigida le cui dimensioni sono indicate nel disegno e tabelle sottostanti.

La seconda, denominata FC, è stata da noi studiata ed è realizzata da una piastrina sagomata con un raggio molto vicino al raggio esterno della protezione rigida ed è regolabile attraverso un'asola longitudinale bloccata con apposite viti.

Questa seconda opzione consente di ridurre al minimo l'accesso all'interno della protezione rigida di corpi estranei o sporcizia presente nell'ambiente.

## FCP

### set-up for end-stop

To control the stroke electrically, we provide two possible set-ups.

The first, called FCP (bridge end-stop set-up), is the commonly used standard and is based on a sheet metal bridge welded onto the rigid protection whose dimensions are shown in the drawing and tables below.

The second, called FC, was designed by us and is made from a shaped plate with a radius very close to the outer radius of the rigid protection and is adjustable through a longitudinal slot secured with special screws.

This second option minimises access to the interior of the rigid protection by foreign bodies or dirt in the environment.

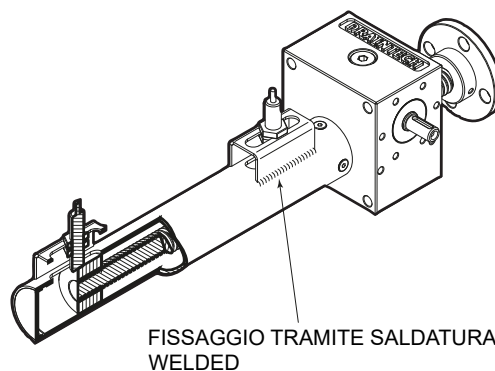
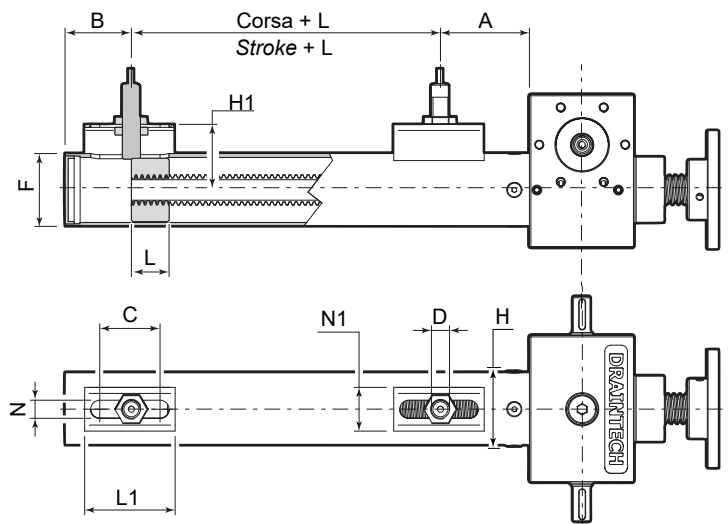

Dimensioni fine corsa a ponte FCP / FCP bridge end-stop dimensions [mm]												
Taglia Size	DHT	183	184	204	306	407	559	609	7010	8010	9010	12014
A		40	40	60	70	75	75	75	90	90	90	110
B		35	35	45	50	50	50	50	70	70	70	90
C		40	40	40	40	40	40	40	40	40	40	40
D		M12	M12	M12	M12	M12	M12	M12	M12	M12	M12	M12
F		33.7	33.7	48.3	63.5	76.1	101.6	101.6	127	127	127	160
H		38	38	52	71	80	104	104	134	134	134	/
H1		35	35	43.5	52.5	60	67	67	90	90	90	100
N		12	12	12	12	12	12	12	12	12	12	12
N1		29	29	29	29	29	29	29	29	29	29	29
L		25	25	25	25	25	25	25	40	40	40	100

Dimensioni fine corsa a ponte FCP / FCP bridge end-stop dimensions [mm]				
Taglia Size	HS	70	100	120
A		60	60	60
B		45	50	50
C		40	40	40
D		M12	M12	M12
F		48.3	63.5	88.9
H		52	71	95
H1		43.5	52.5	61.5
N		12	12	12
N1		29	29	29
L		25	25	25

**FC**  
predisposizione per fine corsa

**FC**  
set-up for end-stop

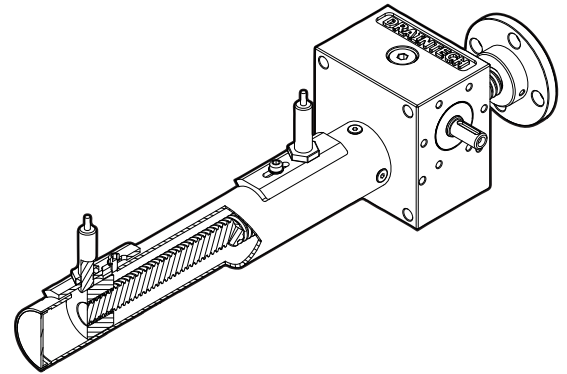
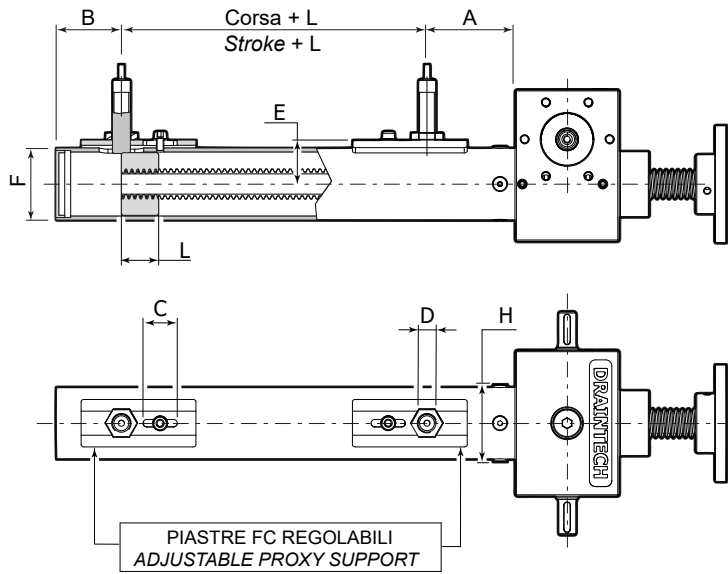

ACC.

Dimensioni fine corsa FC / End-stop dimensions FC  
[mm]

Taglia Size	DHT	183	184	204	306	407	559	609	7010	8010	9010	12014
A		45	45	55	60	70	75	75	75	75	75	100
B		30	30	35	50	50	55	55	55	55	55	85
C		30	30	30	45	45	45	45	45	45	45	45
D		M12	M12	M12	M12	M12	M12	M12	M12	M12	M12	M12
E		30	30	38	47	51	63	63	78	78	78	95
F		33.7	33.7	48.3	63.5	76.1	101.6	101.6	127	127	125	160
H		38	38	52	71	80	104	104	134	134	134	210
L		25	25	25	25	25	25	25	40	40	40	100

Dimensioni fine corsa a ponte FC  
FC bridge end-stop dimensions  
[mm]

Taglia Size	HS	70	100	120
A		60	60	60
B		40	40	40
C		30	45	45
D		M12	M12	M12
E		38	47	60
F		48.3	63.5	88.9
H		52	71	95
L		25	25	25

## MLS

### fine corsa magnetici

I fine corsa magnetici vengono fissati al tubo di protezione dello stelo filettato tramite appositi supporti, che consentono la regolazione della corsa.

In fase della regolazione della corsa, occorre prestare molta attenzione a non superare il limite indicato nella tabella sottostante per evitare che il martinetto raggiunga le posizioni estreme causando battute meccaniche.

Ulteriori informazioni sono riportate sul manuale di uso e manutenzione. I sensori vengono montati nella posizione indicata a disegno, ma per esigenze di montaggio, possono essere ruotati attorno al cannotto di protezione tramite l'apposito supporto.

Sono disponibili tre tipi di sensori:

#### Circuito Reed NC

Circuito con ampolla Reed normalmente chiusa protetta da varistore contro le sovratensioni generate all'apertura del circuito, e sistema di visualizzazione a LED.

#### Circuito Reed NO

Circuito con ampolla Reed normalmente aperta, protetta da varistore contro le sovratensioni generate all'apertura del circuito, e sistema di visualizzazione a LED.

#### Circuito NPN

Circuito con effetto di Hall con uscita NPN. Protetto contro l'inversione di polarità e contro picchi di sovratensione. Sistema di visualizzazione a LED.

## MLS

### magnetic limit switches

The magnetic limit switches are fixed to the screw protection tube by means of special supports that allow for stroke adjustment.

When adjusting the stroke, take care not to exceed the limit indicated in the table below to prevent the jack from reaching extreme positions causing contact with mechanical stops.

Further information can be found in the use and maintenance manual. The sensors are fitted in the position indicated in the drawing, but for assembly requirements they can be rotated around the shield tube by means of the special support.

There are three types of sensor available:

#### NC Reed circuit

Circuit with normally closed reed switch protected by varistor against overvoltage generated when the circuit is opened, and LED display system.

#### NO Reed Circuit

Circuit with normally open reed switch protected by varistor against overvoltage generated when the circuit is opened, and LED display system.

#### NPN Circuit

Circuit with Hall effect with NPN output. Protected against polarity reversal and against peak overvoltage. LED display system opened, and LED display system.

Tipo sensore Sensor type	Circuito Reed NC NC Reed Circuit	Circuito Reed NO NO Reed Circuit	Circuito NPN NPN Circuit
Riferimento Codice d'ordinazione Order code reference	<b>2MLS0</b> 2 Sensori circuito Reed NC (versione standard) 2 Sensors circuit Reed NC (standard version)	<b>2MLS1</b> 2 Sensori circuito Reed NO 2 Sensors circuit Reed NO	<b>2MLS2</b> 2 Sensori NPN 2 Sensors NPN
Tensione in DC / DC voltage	3 / 110 V	3 / 30 V	6 / 30 V
Tensione in AC / AC voltage	3 / 110 V	3 / 30 V	-
Corrente / Current 25 °C	0,5 A	0,1 A	0,20 A
Potenza / Power	20 VA	6 VA	4 W
Cavo alimentazione / Supply cable	PVC 2 x 0,14 mm	PVC 2 x 0,14 mm	PVC 3 x 0,14 mm
Lunghezza cavo / Cable length	2500 mm	2.500 mm	2.500 mm
Protezione / Protection	IP67	IP67	IP67
Schema circuito / Circuit diagram			

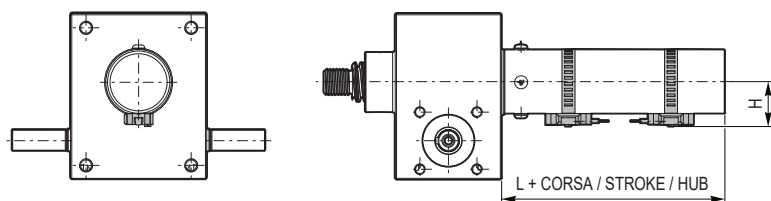

Dimensioni / Dimensions			
Taglia Size		H	L
DHT183, 184		29	71
DHT204	HS70	34	76
DHT306	HS100	42	94
	HS120	55	115

**RGT**  
**recupero gioco**

L'accoppiamento tra asta trapezia e madrevite presenta un naturale e necessario gioco in senso assiale.

Esistono però applicazioni tali per cui questo gioco deve essere ridotto in parte o totalmente ed installando il dispositivo di recupero gioco RGR o RGT è possibile farlo.

Occorre però regolare con attenzione il gioco del sistema in quanto un'eccessiva riduzione di gioco porta al bloccaggio della madrevite e ad un'usura precoce oltre ad abbassare il rendimento della macchina.

Il sistema è progettato in maniera tale per cui in caso di usura è possibile ripristinare il gioco desiderato semplicemente avvitando il fondello superiore del martinetto senza doverlo necessariamente smontare dalla macchina (vedi schema per la registrazione del gioco sotto riportato).

Dimensionalmente il martinetto è esattamente uguale al martinetto standard in quanto tutto il sistema è alloggiato all'interno del carter e non è visibile dall'esterno.

**ATTENZIONE:** è possibile notare una lieve fuoriuscita di lubrificante nella zona di accoppiamento fondello superiore-cassa.

**SISTEMA NON DISPONIBILE PER MODELLI DHT183 / DHT184 E PER MODELLI SUPERIORI ALLA TAGLIA DHT609.**

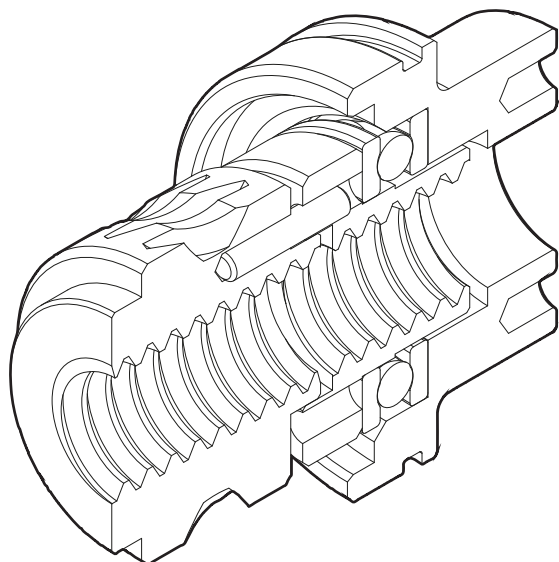

**RGT**  
**backlash recovery**

*The coupling between the trapezoidal rod and the nut has a natural and necessary backlash in the axial direction.*

*However, there are applications such that this backlash must be reduced in part or in full, and by installing the RGR or RGT backlash recovery device, this can be done.*

*However, the backlash of the system must be carefully adjusted, as excessive backlash leads to jamming of the nut and premature wear, as well as lowering the machine's efficiency.*

*The system is designed in such a way that in the event of wear, the desired clearance can be restored simply by screwing the upper end cap of the screw jack without necessarily having to remove it from the machine (see backlash adjustment diagram below).*

*Dimensionally, the screw jack is exactly the same as the standard screw jack in that the entire system is housed inside the casing and is not visible from the outside.*

**ATTENTION:** *You may notice a slight leakage of lubricant in the area of the upper case-bottom coupling.*

**SYSTEM NOT AVAILABLE FOR MODELS DHT183 / DHT184 AND FOR MODELS LARGER THAN SIZE DHT609.**

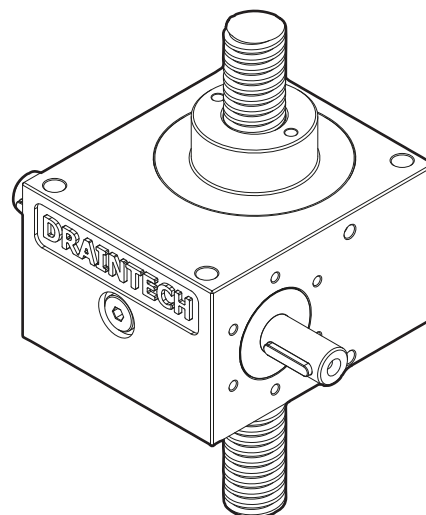

## RGR recupero gioco

Anche per i martinetti ad asta rotante sono disponibili sistemi per il recupero del gioco assiale da applicare alle chiocciolate.

Il gioco viene registrato con un sistema di viti e grani per la regolazione della distanza assiale della controchiocciola schematizzati nelle figure sottostanti.

Questi dispositivi sono idonei per tutte quelle applicazioni dove si hanno carichi che agiscono sulla chiocciola sia in spinta che in trazione contemporaneamente oppure nel caso di posizionamento statico dove anche il minimo gioco assiale non sia consentito.

E' disponibile un sistema (RGR) che utilizza le chiocciolate in bronzo standard, quelle che, per intenderci, vengono abitualmente montate sui martinetti rotanti con flangia a 4 fori.

## RGR backlash recovery

*Axial backlash recovery systems are also available for rotating rod screw screw jacks.*

*The backlash is adjusted using a system of screws and grub screws for adjusting the axial distance of the mating nut shown in the figures below.*

*These devices are suitable for all applications where loads act on the nut in both push and pull directions at the same time, or in the case of static positioning where even the slightest axial backlash is not permitted.*

*A system (RGR) is available that uses standard bronze nuts, those that are usually mounted on rotating screw jacks with a 4-hole flange.*

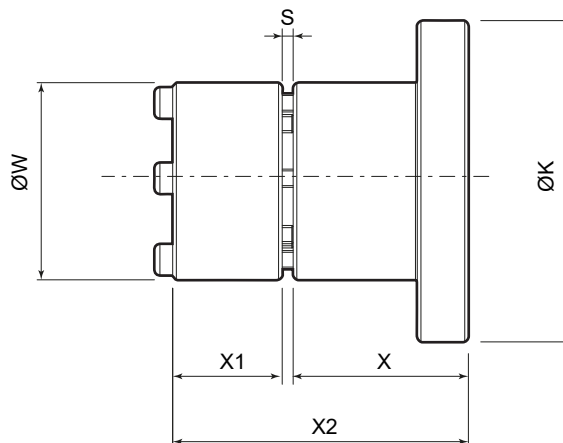
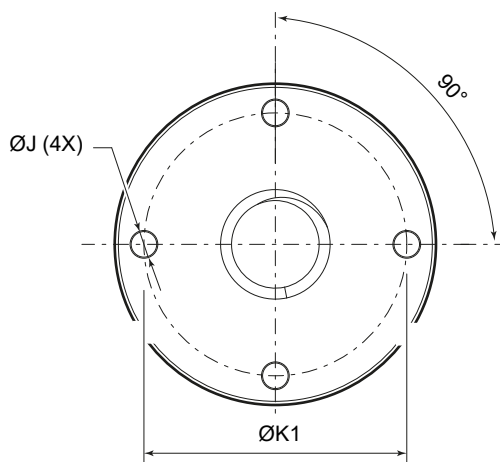
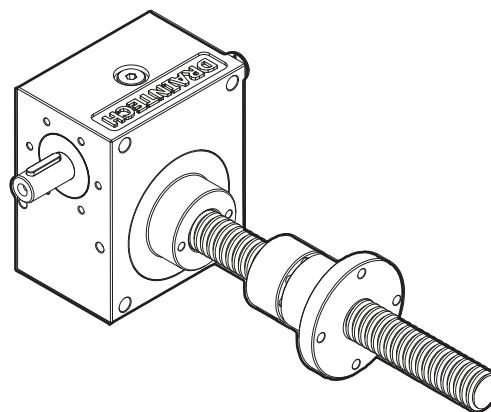
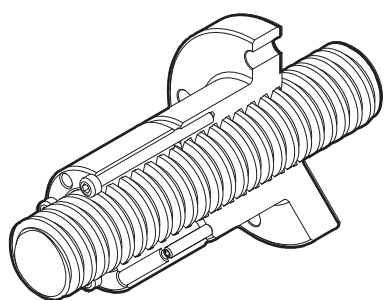

Dimensioni / Dimensions  
[mm]

Taglia Size	DHT	204	306	407	559	609	7010	8010
X		45	48	75	100	120	105	110
X1		35	38	64	89	89	90	95
X2		82	89	142.5	193.5	213	200	210
Y		12	14	16	20	25	30	30
ØK		60	80	96	130	110	180	190
ØK1		45	64	78	100	92	140	150
ØW		32	46	60	76	76	100	110
ØJ		7	7	9	13	10.5	18	18
S		2	3	3.5	4.5	4.5	5	5

**RGR BIG**  
recupero gioco

Anche per i martinetti ad asta rotante sono disponibili sistemi per il recupero del gioco assiale da applicare alle chioccioline.

Il gioco viene registrato con un sistema di viti e grani per la regolazione della distanza assiale della controchiocciola schematizzati nelle figure sottostanti.

Questi dispositivi sono idonei per tutte quelle applicazioni dove si hanno carichi che agiscono sulla chiocciola sia in spinta che in trazione contemporaneamente oppure nel caso di posizionamento statico dove anche il minimo gioco assiale non sia consentito.

E' disponibile una versione con chiocciola flangiata maggiorata che abbiamo nominato RGR BIG con flangia a 8 fori e diametri maggiorati.

**RGR BIG**  
backlash recovery

Axial backlash recovery systems are also available for rotating rod screw jacks.

The backlash is adjusted using a system of screws and grub screws for adjusting the axial distance of the mating nut shown in the figures below.

These devices are suitable for all applications where loads act on the nut in both push and pull directions at the same time, or in the case of static positioning where even the slightest axial backlash is not permitted.

An oversized flanged nut version is available, which we have named RGR BIG with an 8-hole flange and increased diameters.

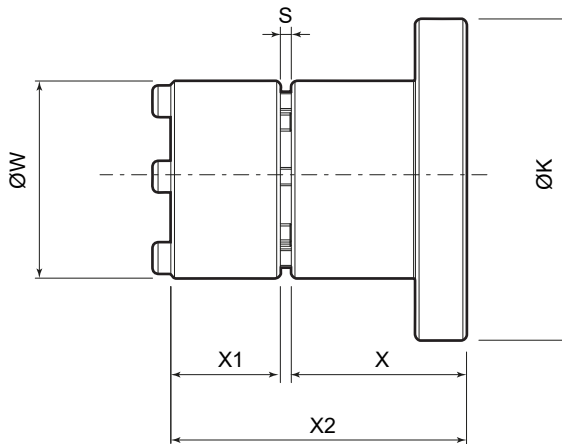
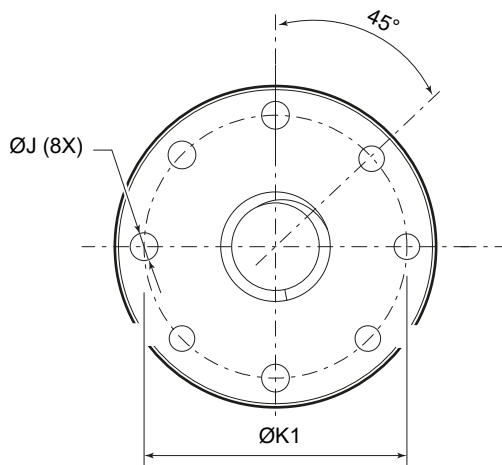
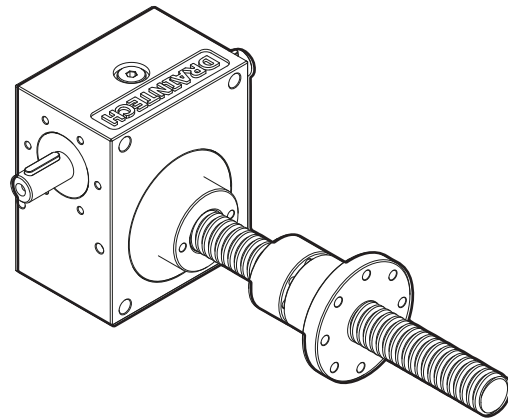
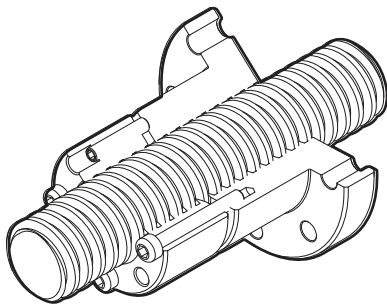

Dimensioni / Dimensions [mm]						
Taglia Size	DHT	204	306	407	559	609
X		45	48	75	76	76
X1		30	30	75	68	68
X2		77	81	153.5	148.5	148.5
Y		12	14	16	16	16
ØK		70	88	104	120	120
ØK1		55	72	86	105	105
ØW		36	54	68	85	85
ØJ		7	7	9	9	9
S		2	3	3.5	4.5	4.5

## GR guida rotante

## GR rotary guide

La guida rotante si applica sui modelli HST.  
Montata sull'albero cavo sul lato opposto alla chiocciola, fornisce un'ulteriore guida alla vite a ricircolo di sfere per mantenere la traslazione della vite a ricircolo in asse con la ruota elicoidale.

*The rotating guide applies to HST models.  
Mounted on the hollow shaft on the opposite side of the nut, it provides additional guidance to the ball screw to keep it on axis with the helical gear.*

Dimensioni / Dimensions [mm]				
Taglia Size	HS	70	100	120
ØD1 g6		75	115	150
D2		59	72	105
D3		Dimensioni variabili in funzione della chiocciola Variable dimensions depending on the nut		
D5				
L1				
L2				
L3				
F1		7	11	13

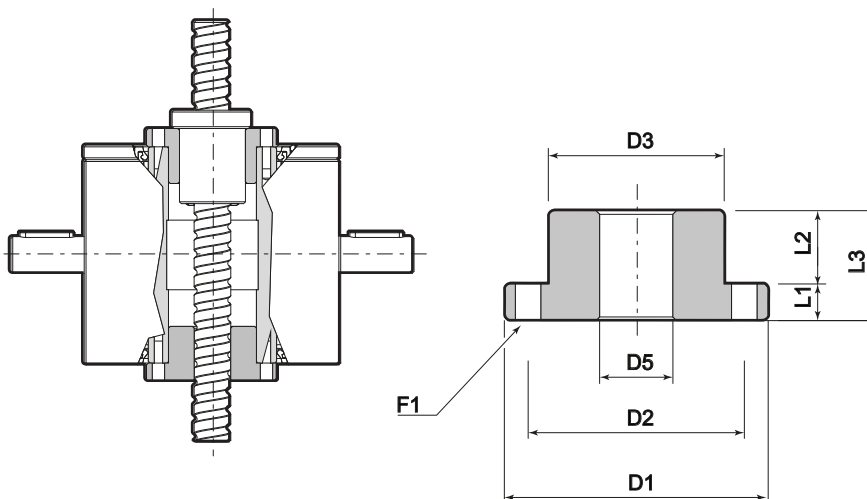

## GSI guida statica inferiore

## GSI lower static guide

La guida statica si applica sui modelli HST.  
Montata sul lato inferiore del carter, fornisce un'ulteriore guida alla vite a ricircolo di sfere per mantenere la traslazione della vite a ricircolo in asse con la ruota elicoidale.

*Static guide applies to HST models.  
Mounted on the underside of the casing, it provides an additional guide to the ball screw to keep the ball screw translation on axis with the helical gear.*

Dimensioni / Dimensions [mm]				
Taglia Size	HS	70	100	120
ØD1 g6		110	160	200
D2		96	143	182
D3		Dimensioni variabili in funzione della chiocciola Variable dimensions depending on the nut		
D4				
L1				
L2				
L3				
L4		3	3	3
D5		85	125	170
F1		7	7	7

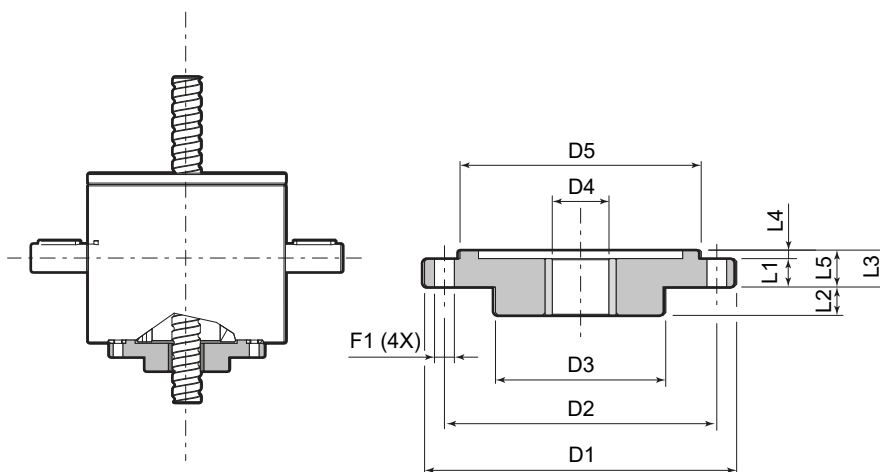

**GSS**

**guida statica superiore**

La guida statica si applica sui modelli HST.  
Montata sul lato superiore del carter, fornisce un'ulteriore guida alla vite a ricircolo di sfere per mantenere la traslazione della vite a ricircolo in asse con la ruota elicoidale.

**GSS**

**upper static guide**

Static guide applies to HST models.  
Mounted on the upper side of the casing, it provides an additional guide to the ball screw to keep the ball screw translation on axis with the helical gear.

Dimensioni / Dimensions [mm]				
Taglia Size	HS	70	100	120
ØD1	g6	110	160	200
D2		96	143	182
D3	Dimensioni variabili in funzione della chiocciola Variable dimensions depending on the nut			
D4				
L1				
L2				
L3				
L5				
L4		3	3	3
D5		85	125	170
F1		7	7	7

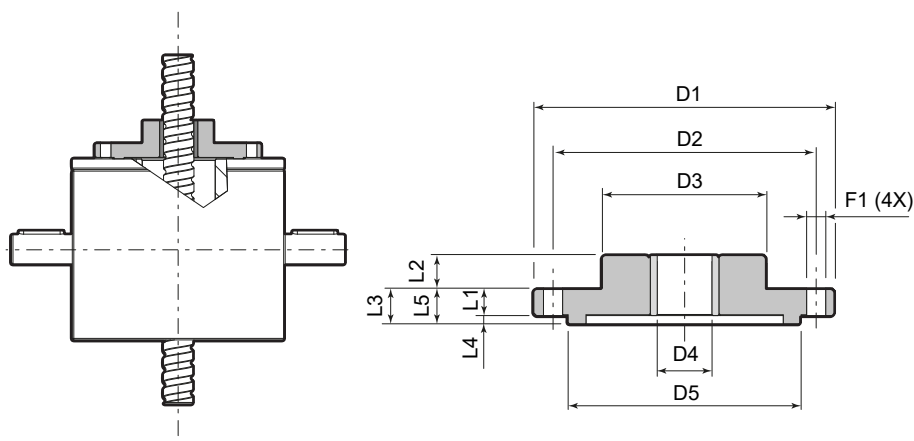

ACC.

**SP**  
piastre supplementari

**SP**  
additional plates

Permettono il fissaggio del martinetto ad interassi diversi rispetto a quelli del carter.

*They allow the screw jack to be attached at different centre distances to the casing.*

100B1356 Dimensioni / Dimensions [mm]				
Taglia Size	HS	70	100	120
A		140	200	240
A1		12	13	20
A2		116	174	200
A3		25	30	50
A4		90	140	140
B		175	238	310
B1		12.5	15	25
B2		200	268	360
B3		25	30	50
B4		70	100	120
B5		105	138	190
B6		225	298	410
ØF1		11	15	25
H1		20	25	45
H2		80	100	135

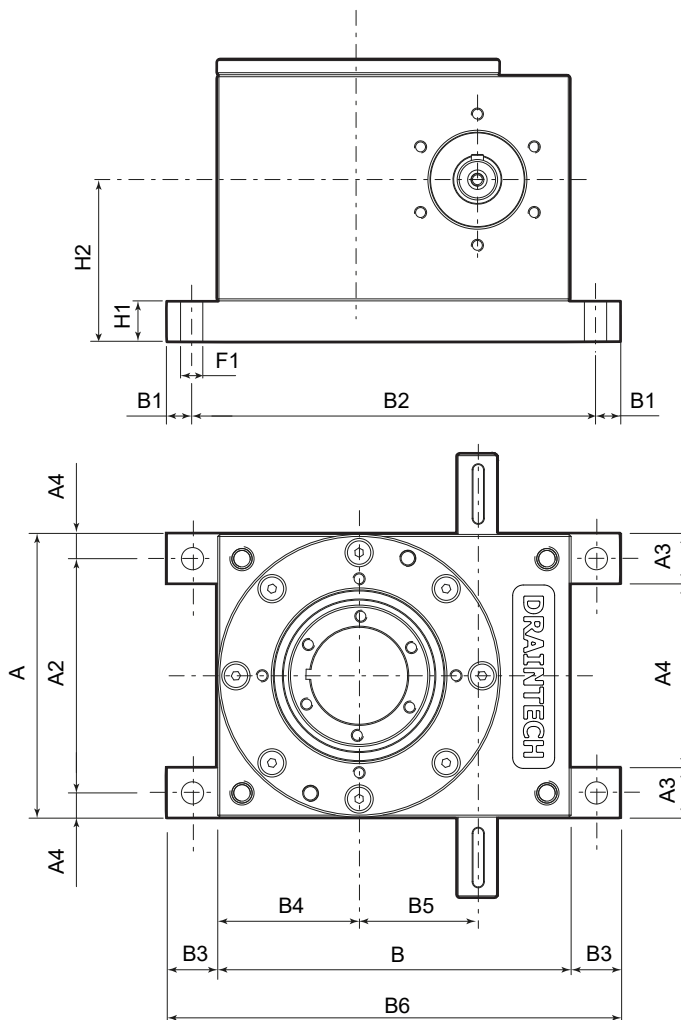

**TS**  
alberi di trasmissione

**TS**  
drive shafts

Alberi con mozzi a morsetto:

- pratico montaggio radiale tramite mozzi a morsetto
- semplicità di montaggio e di regolazione grazie ai morsetti
- fornibile a richiesta con sede linguetta
- in alluminio ad alta resistenza (INOX su richiesta)
- stelle in elastomero senza giochi con durezza Shore 64D
- temperatura di funzionamento da -10 °C fino a 70 °C

Shafts with clamp hubs:

- practical radial mounting via clamping hubs
- easy assembly and adjustment thanks to clamps
- can be supplied with tab seat on request
- high-strength aluminium (stainless steel on request)
- backlash-free elastomer stars with Shore hardness 64D
- operating temperature -10 °C to 70 °C

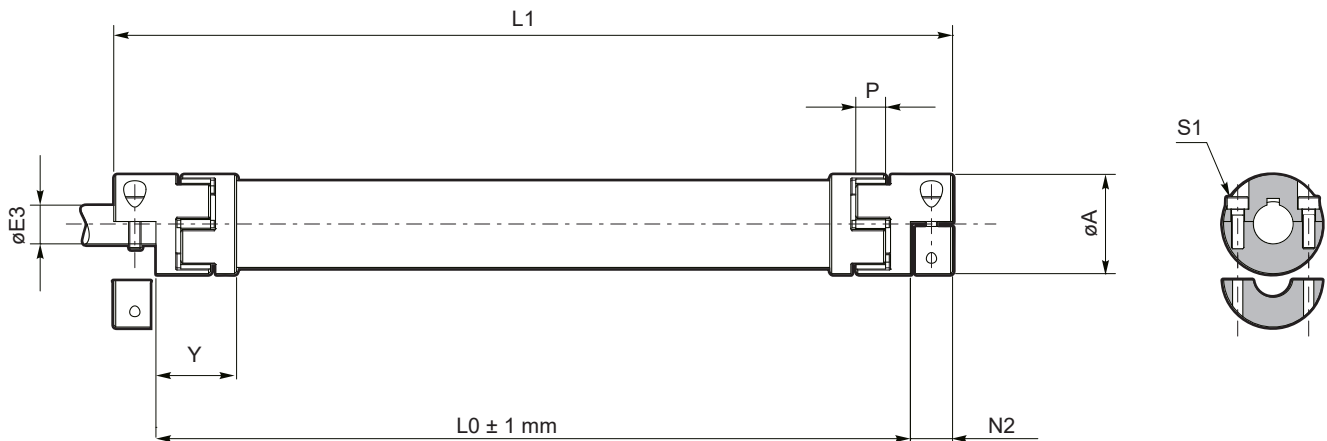

L0 = distanza tra gli alberi dei martinetti o dei rinvii da unire

L0 = distance between screw jack or gearbox shafts to be joined

Taglia albero Shaft size	A	E3 Min.	E3 Max.	N2	P	Y	Dt	L1	Peso Allunga Extension weight [Kg/m]	Peso tot. Total weight [Kg]	L0 [mm]	S1	Coppia di serraggio Tightening torque [Nm]
TS14	Ø 30	6	15	14	12	20.5	30	28 + L0	1.06	0.03 + Peso allunga 0.03 + Extension weight	58	M4	3.1
TS19	Ø 40	8	20	19	16	30.5	35	38 + L0	1.27	0.15 + Peso allunga 0.15 + Extension weight	95	M5	6.2
TS24	Ø 55	10	30	22	18	37.5	50	44 + L0	1.91	0.28 + Peso allunga 0.28 + Extension weight	113	M6	10.5
TS28	Ø 65	14	35	25	20	41	60	50 + L0	3.34	0.55 + Peso allunga 0.55 + Extension weight	131	M8	25
TS38	Ø 80	15	45	34	24	46	70	68 + L0	5.099	0.98 + Peso allunga 0.98 + Extension weight	161	M8	25

Taglia albero Shaft size	Coppie trasmissibili bloccaggio a morsetto tipo C Transmittable torques type C clamping clamp [Nm]																			
	6	8	9	10	11	12	14	15	16	-	-	-	-	-	-	-	-	-	-	-
TS14	6	8	9	10	11	12	14	15	16	-	-	-	-	-	-	-	-	-	-	-
TS19	-	14	16	17	19	21	24	26	28	31	33	35	33	36	-	-	-	-	-	-
TS24	-	-	-	20	22	24	28	30	32	36	38	40	44	48	50	57	61	-	-	-
TS28	-	-	-	-	-	-	55	59	63	71	75	79	86	94	98	110	118	126	137	128
TS38	-	-	-	-	-	-	-	59	63	71	75	79	86	94	98	110	118	126	137	149

**TS**  
alberi di trasmissione

**TS**  
drive shafts

**DIAGRAMMA DELLE VELOCITA' / SPEED DIAGRAM**

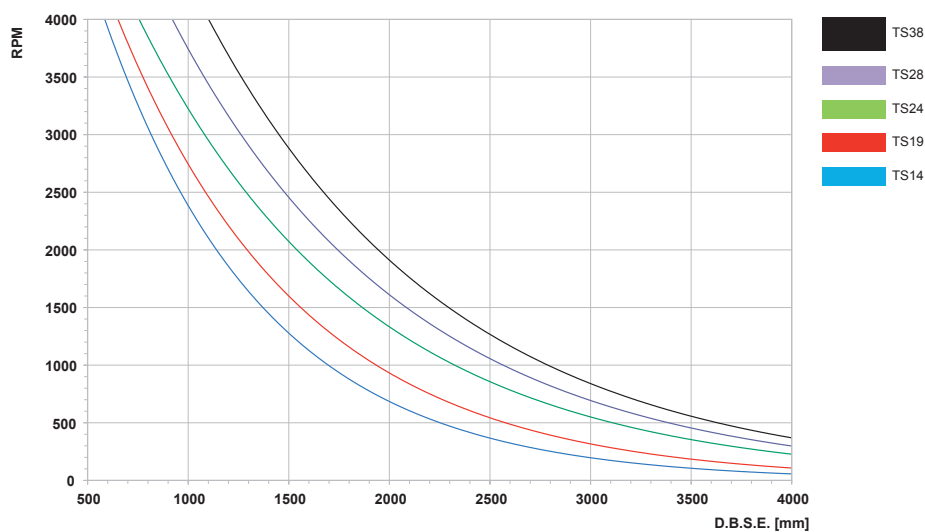

Taglia albero Shaft size	Lunghezza minima Minimum length [mm]
TS14	86
TS19	133
TS24	157
TS28	181
TS38	229

**SIGLA DI ORDINAZIONE / ORDERING CODE**

1	2	3	4
Taglia Size	Lunghezza Length  L1 [mm]	Diametro foro giunti Coupling hole diameter  d [mm]	Diametro foro giunti Coupling hole diameter  d [mm]
TS19	500	16	16

- TS14
- TS19
- TS24
- TS28
- TS38

Lunghezza L1  
Length L1  
[mm]

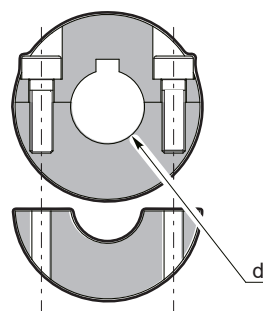
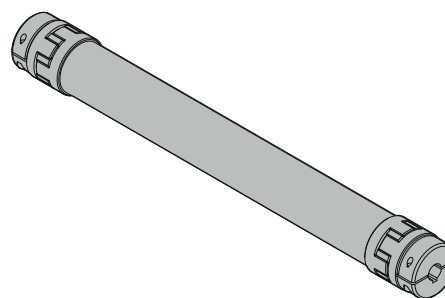

d = Foro giunto (passaggio albero)  
L1= Lunghezza totale albero comprensivo di giunti

d = Coupling hole (shaft passage)  
L1= Total shaft length including couplings

**TS**  
alberi di trasmissione

**TS**  
drive shafts

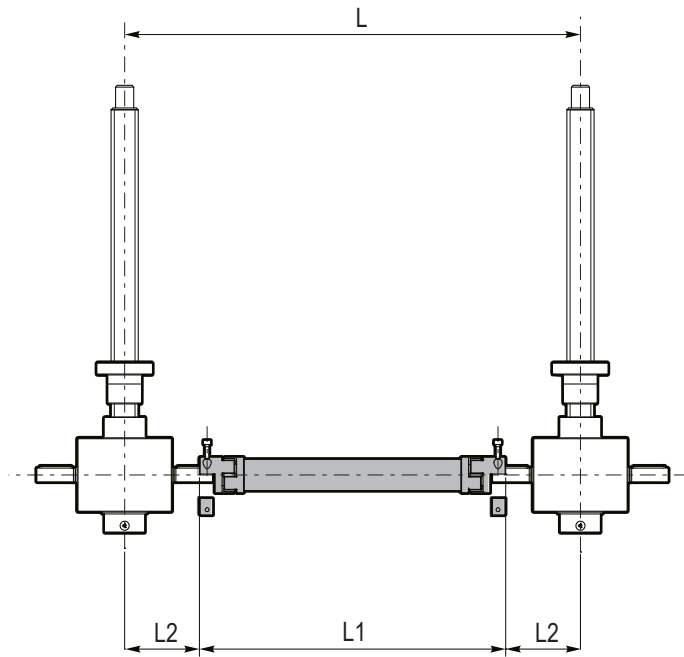

$$L1 = L - (2 \times L2)$$

L = Interasse martinetti  
L1= Lunghezza totale albero comprensivo di giunti

L = Screw jack centre distance  
L1= Total shaft length including couplings

Taglia martinetto Screw jack size	Taglia albero di trasmissione Transmission shaft size	L2 [mm]
DHT183 DHT184	TS14	45
	TS19	40
	TS24	37
DHT204	TS14	61
	TS19	56
DHT306	TS24	53
	TS19	84
	TS28	81
DHT407	TS24	113
	TS28	110
	TS38	101
DHT559 DHT609	TS28	112.5
	TS38	103.5
DHT7010	TS28	150
	TS38	141

Taglia martinetto Screw jack size	Taglia albero di trasmissione Transmission shaft size	L2 [mm]
HS70	TS19	91
	TS24	88
	TS28	85
HS100	TS24	128
	TS28	125
	TS38	116
HS120	TS28	155
	TS38	146

**GR**  
giunto

**GR**  
coupling

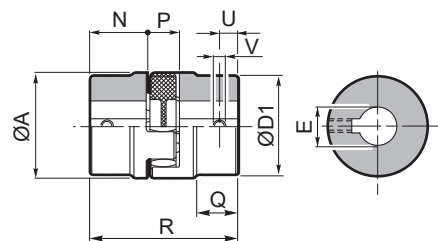
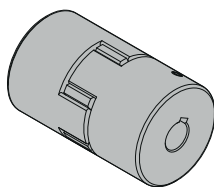

Taglia albero Shaft size	A	D1	E Max	N	P	Q	R	U	V	Peso Weight [Kg]
14	30	-	16	11.5	12	-	35	5	M4	0.03
19	40	-	25	25	16	-	66	10	M5	0.15
24	55	53	35	30	18	20	78	10	M5	0.28
28	65	63	40	35	20	24	90	15	M8	0.55
38	80	78	48	45	24	33	114	15	M8	0.98







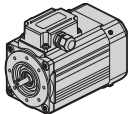

Screw  
Jacks

Motori applicabili  
Applicable motors

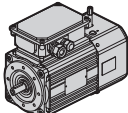

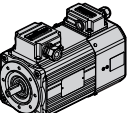

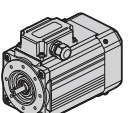
				Pag. Page
		Motori elettrici CA <b>SM</b>	Electric motors AC <b>SM</b>	E2
		Motori elettrici CA autofrenanti <b>SMT..BR</b>	Electric motors AC self-braking <b>SMT..BR</b>	E10
		Motori elettrici CA servoventilati <b>SMT..SV</b>	Electric motors AC servo-ventilated <b>SMT..SV</b>	E14
		Motori elettrici CA <b>SM..UL/CSA</b>	Electric motors AC <b>SM..UL/CSA</b>	E18

Questa sezione annulla e sostituisce ogni precedente edizione o revisione. Qualora questa sezione non Vi sia giunta in distribuzione controllata, l'aggiornamento dei dati ivi contenuto non è assicurato. **In tal caso la versione più aggiornata è disponibile sul nostro sito internet [www.transtecno.com](http://www.transtecno.com)**

*This section replaces any previous edition and revision. If you obtained this catalogue other than through controlled distribution channels, the most up to date content is not guaranteed. **In this case the latest version is available on our web site [www.transtecno.com](http://www.transtecno.com)***

## Motori elettrici CA - SM

## AC electric motors - SM

### Caratteristiche tecniche

### Technical features

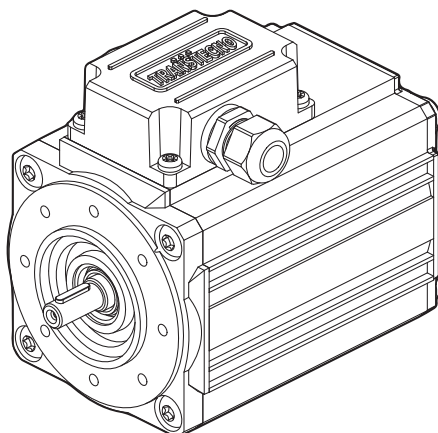
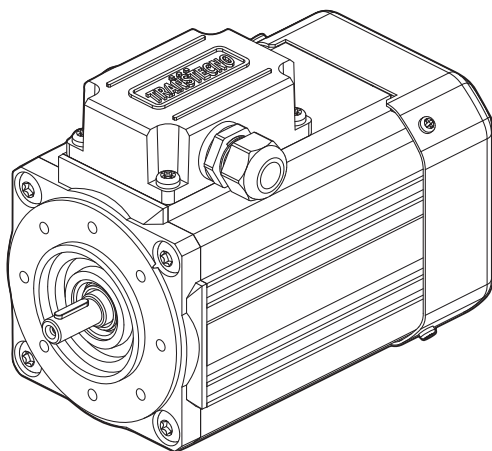

## SM .. TEFC

## SM .. TEFC

I motori delle serie SMT ed SMM hanno le seguenti caratteristiche principali:

The SMT and SMM series motors have the following main features:

- Costruzione compatta
- Motorizzazioni in corrente alternata monofase e trifase
- Carcassa estrusa in alluminio anodizzato nero
- Motore elettrico CA con grado di protezione IP66
- Rumorosità e vibrazioni contenute
- Isolamento termico di classe F
- Flangia motore IEC B14
- Temperatura ambiente: -20°C / + 40°C
- Disponibili sia nella versione ventilata TEFC (servizio S1) che non ventilata TENV (servizio S3)
- Protezioni termiche PTO 150°C per le taglie 56, 63, 71, 80 e 90.
- SMT56, SMT63, SMT71, SMT80 e SMT90 adatti al funzionamento con alimentazione da inverter.
- SMT80 e SMT90 conformi alla classe di rendimento IE3.
  
- Cava esagonale su albero motore lato NDE.
- Condensatore di marcia sempre cablato ad esclusione della taglia SMM50.
- La tolleranza di tensione è  $\pm 10\%$  per tutti i motori ad esclusione della taglia 50 ( $\pm 5\%$ ).
- Disponibili nelle versioni autofrenante, servovergilata e con certificazione UL/CSA.

- Compact construction
- Single-phase and three-phase AC motors
- Extruded black anodised aluminium casing
- AC electric motor with IP66 protection rating
- Low noise and vibration
- Class F thermal insulation
- IEC B14 motor flange
- Ambient temperature: -20°C / + 40°C
- Available in both TEFC-ventilated (S1 service) and TENV-unventilated (S3 service) versions
- Thermal protection PTO 150°C for sizes 56, 63, 71, 80 and 90.
- SMT56, SMT63, SMT71, SMT80 and SMT90 suitable for inverter-powered operation.
- SMT80 and SMT90 complying with efficiency class IE3.
  
- Hexagon socket on motor shaft NDE side.
- Start capacitor always wired except for size SMM50.
- The voltage tolerance is  $\pm 10\%$  for all motors except size 50 ( $\pm 5\%$ ).
- Available in self-braking, servo-ventilated and UL/CSA certified versions.

**Simbologia AC**

$P_n$	[kW]	Potenza nominale
$I_n$	[A]	Corrente nominale (a 400V)
$M_n$	[Nm]	Coppia nominale
$n_n$	[rpm]	Velocità nominale
LR	[dB]	Livello di rumorosità
$M_s / M_n$		Rapporto coppia spunto / coppia nominale
$M_k / M_n$		Rapporto coppia massima / coppia nominale
$M_{sel} / M_n$		Rapporto coppia di sella (minima) / coppia nominale
$I_s / I_n$		Rapporto corrente di spunto / corrente nominale
$\cos\varphi$		Fattore di potenza al carico nominale
$\eta$		Rendimento al carico nominale
S		Servizio
$M_b$	[Nm]	Coppia frenante
$P_{sf}$	[W]	Potenza assorbita servoventola

**Symbols AC**

Nominal power
Nominal current (at 400V)
Nominal torque
Rated speed
Noise level
Inrush torque/rated torque ratio
Maximum torque/rated torque ratio
Saddle torque (minimum) / nominal torque ratio
Inrush current/rated current ratio
Power factor at rated load
Efficiency at rated load
Service
Braking torque
Servo fan power consumption

**Dati tecnici**

**Technical data**

**SMT Motori trifase / Three-phase motors**

(230-400 V / 50 Hz) poli / poles 4

Tipo Type	$P_n$ [kW]	$M_n$ [Nm]	$n_n$ [min <sup>-1</sup> ]	$I_n$ (400V) [A]	$\eta$ %	$\cos\varphi$	$M_s/M_n$	$I_s/I_n$	$M_k/M_n$	PTO	S TEFC	S TENV	
5014	0.04	0.30	1290	0.25	34.0	0.68	1.65	1.75	1.70	-	S1	S3 30%	
5024	0.06	0.44	1300	0.35	35.7	0.69	1.55	1.80	1.60				
5034	0.09	0.65	1315	0.54	38.0	0.64	1.80	2.00	1.85				
5044	0.12	0.87	1315	0.64	43.0	0.63	1.80	2.00	1.80				
5624	0.09	0.64	1345	0.45	46.5	0.62	2.50	2.40	2.70	PTO 150°	S1	S3 50%	
5634	0.12	0.89	1300	0.45	52.0	0.74	1.90	2.40	1.90				
5644	0.18	1.26	1360	0.69	59.0	0.65	2.50	3.00	2.60				
5654	0.25	1.80	1330	0.93	59.0	0.66	2.50	2.80	2.60				
6324	0.18	1.26	1360	0.69	57.0	0.66	2.50	2.90	2.50				
6334	0.25	1.74	1375	0.94	62.0	0.64	2.80	3.00	2.80				
6344	0.37	2.60	1360	1.24	65.3	0.66	2.70	3.00	2.70				
7124	0.37	2.52	1400	1.10	67.9	0.72	2.75	4.20	2.75				
7134	0.55	3.76	1395	1.55	70.2	0.73	2.90	4.40	2.90				
7144	0.75	5.09	1405	2.00	74.0	0.73	2.90	5.00	2.90				
IE3	8024 IE3	0.75	4.96	1440	1.94	82.5	3.6	6.00	3.70		S1		S3 70%
	8034 IE3	1.1	7.25	1450	2.91	84.1	4.0	6.80	4.40				
	9024 IE3	1.5	10.0	1430	3.48	85.3	3.2	6.30	3.50				
	9034 IE3	2.2	14.9	1410	4.68	86.7	0.79	3.0	6.20	3.30			

**SMM Motori monofase / Single-phase motors (230 V / 50 Hz) poli / poles 4**

Type Type	$P_n$ [kW]	$M_n$ [Nm]	$n_n$ [min <sup>-1</sup> ]	$I_n$ (230V) [A]	$\eta$ %	$\cos\varphi$	$M_s/M_n$	$I_s/I_n$	$M_k/M_n$	Cond./Cap. [μF]	PTO	S TEFC	S TENV
5014	0.04	0.27	1390	0.60	33.4	0.88	0.74	1.60	1.55	8.0	-	S1	S3 30%
5024	0.06	0.42	1380	0.89	34.3	0.85	0.76	1.70	1.50	12.0			
5034	0.09	0.63	1375	1.10	40.0	0.89	0.80	1.70	1.45	16.0			
5624	0.09	0.63	1370	0.82	48.6	0.98	0.72	1.70	1.45	6.3			
5634	0.12	0.83	1380	1.06	50.3	0.98	0.75	2.10	1.65	9.0	PTO 150°	S1	S3 50%
5644	0.18	1.25	1375	1.50	53.8	0.97	0.70	2.20	1.58	12.5			
6324	0.18	1.33	1290	1.50	54.5	0.97	1.00	1.80	1.45	12.0			
6334	0.25	1.85	1290	1.95	56.8	0.98	0.93	1.90	1.50	16.0			
7124	0.37	2.72	1300	2.78	58.6	0.99	0.77	2.00	1.35	20.0			
7134	0.55	3.95	1330	3.54	68.9	0.98	0.66	2.40	1.40	25.0			
8024	0.75	5.31	1350	4.93	67.4	0.98	0.67	2.50	1.54	35.0			

Per dimensioni e ulteriori dati consultare la documentazione disponibile sul sito [www.transtecno.com](http://www.transtecno.com)  
For dimensions and further data please refer to the documentation available at [www.transtecno.com](http://www.transtecno.com)

3~

SMT50.. - B14 - TEFC / TENV

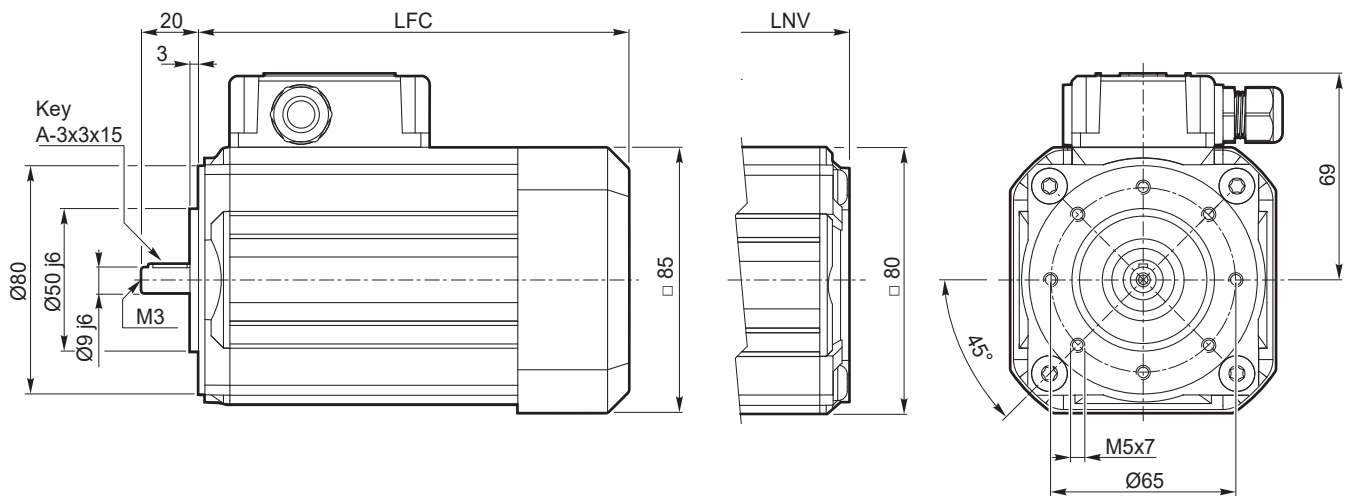

SMT	... TEFC		... TENV	
	LFC	kg	LNV	kg
5014	135.5	2.3	108.5	2.2
5024	150.5	2.7	123.5	2.6
5034	175.5	3.5	148.5	3.4
5044	200.5	4.2	173.5	4.1

3~

SMT56.. - B14 - TEFC / TENV

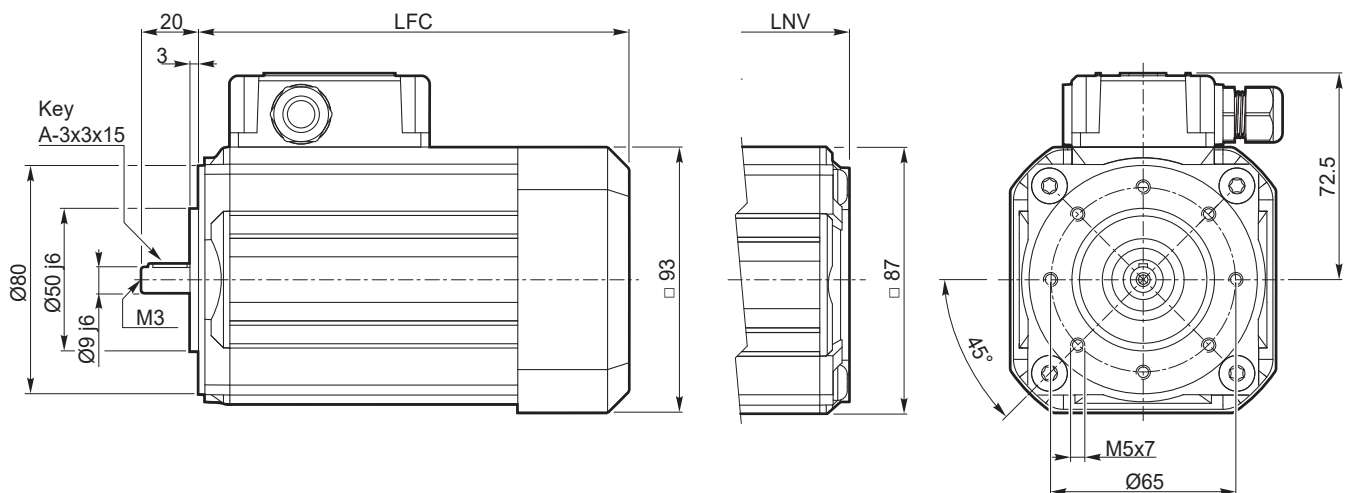

SMT	... TEFC		... TENV	
	LFC	kg	LNV	kg
5624	141	2.9	117	2.8
5634	151	3.2	127	3.1
5634 IE2	171	3.8	-	-
5644	186	4.4	162	4.3
5654	206	5.1	182	5.0

Dimensioni motori trifase

Dimensions of three-phase motors

3~

SMT63.. - B14 - TEFC / TENV

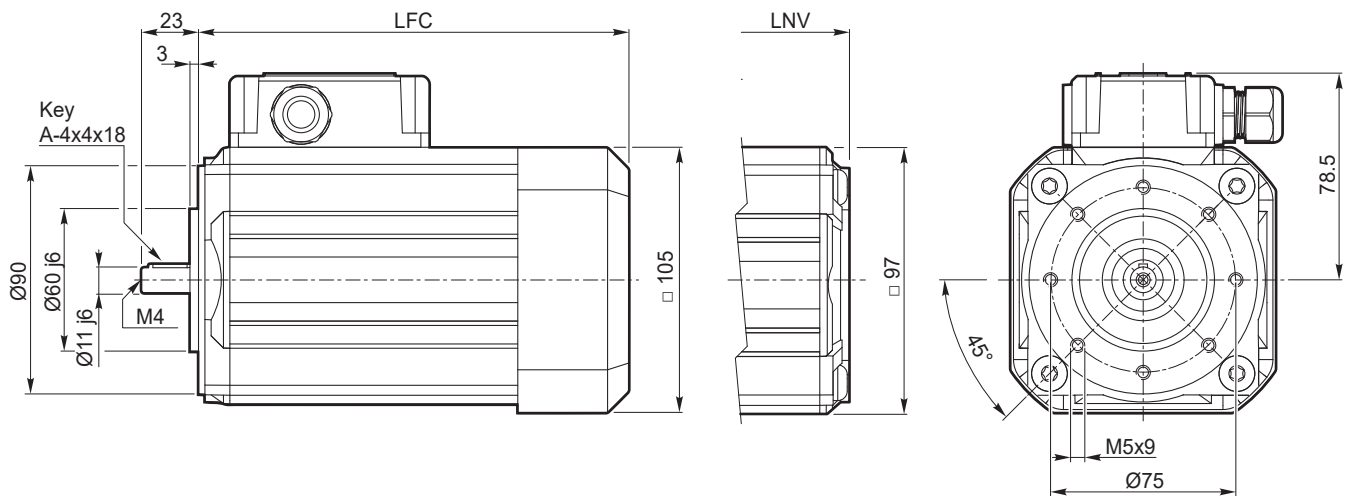

SMT	... TEFC		... TENV	
	LFC	Kg	LNV	Kg
6324	165.5	4.3	138.5	4.2
6324 IE2	180.5	4.9	-	-
6334	180.5	5.0	153.5	4.9
6334 IE2	205.5	6.1	-	-
6344	205.5	6.2	178.5	6.1

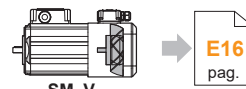
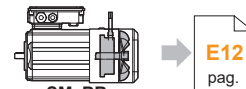

3~

SMT71.. - B14 - TEFC / TENV

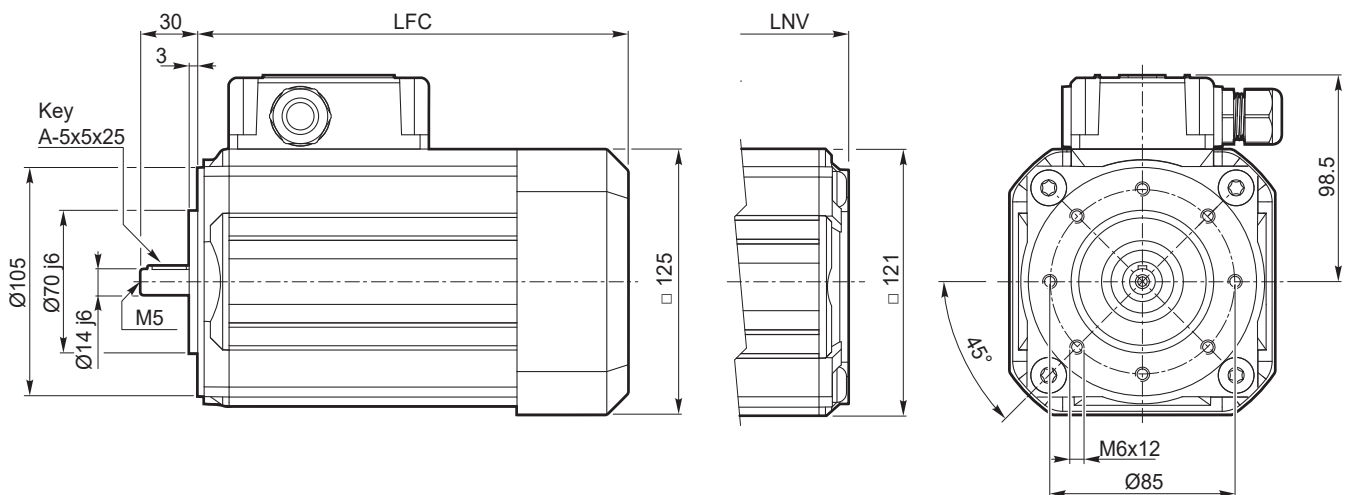

SMT	... TEFC		... TENV	
	LFC	Kg	LNV	Kg
7124	174	6.6	145.5	6.4
7124 IE2	189	7.5	-	-
7134	189	7.7	160.5	7.5
7134 IE2	214	9.2	-	-
7144	214	9.4	185.5	9.2

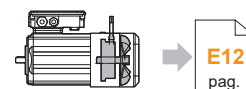

3~

SMT80.. - B14 - TEFC / TENV

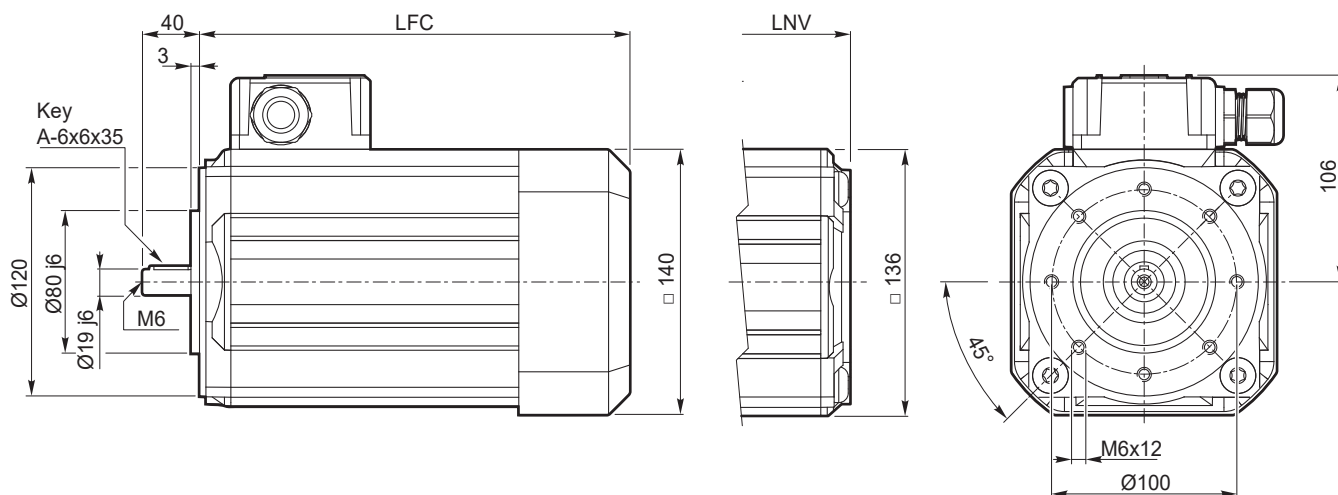

SMT	... TEFC		... TENV	
	LFC	kg	LNV	kg
8024	233	11.8	196	11.5
8034	283	16.8	246	16.5

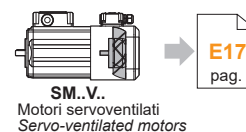
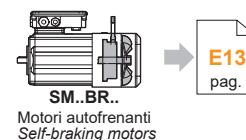

3~

SMT90.. - B14 - TEFC / TENV

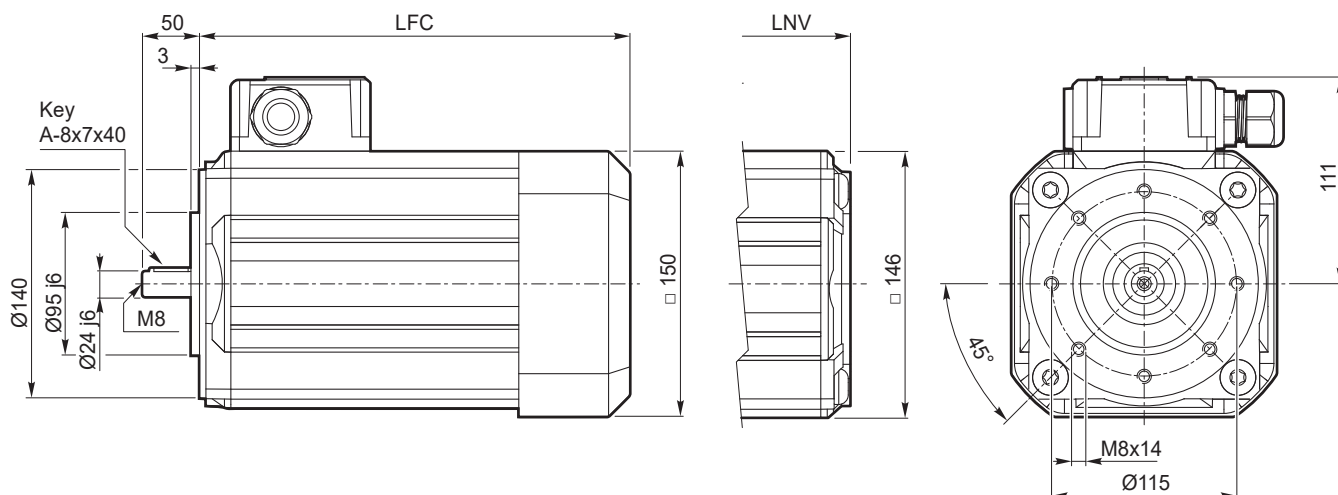

SMT	... TEFC		... TENV	
	LFC	kg	LNV	kg
9024	283	18.2	246	17.9
9034	313	21.5	276	21.2

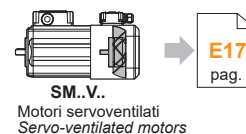
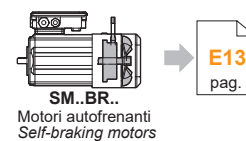

1 ~

SMM50.. - B14 - TEFC / TENV

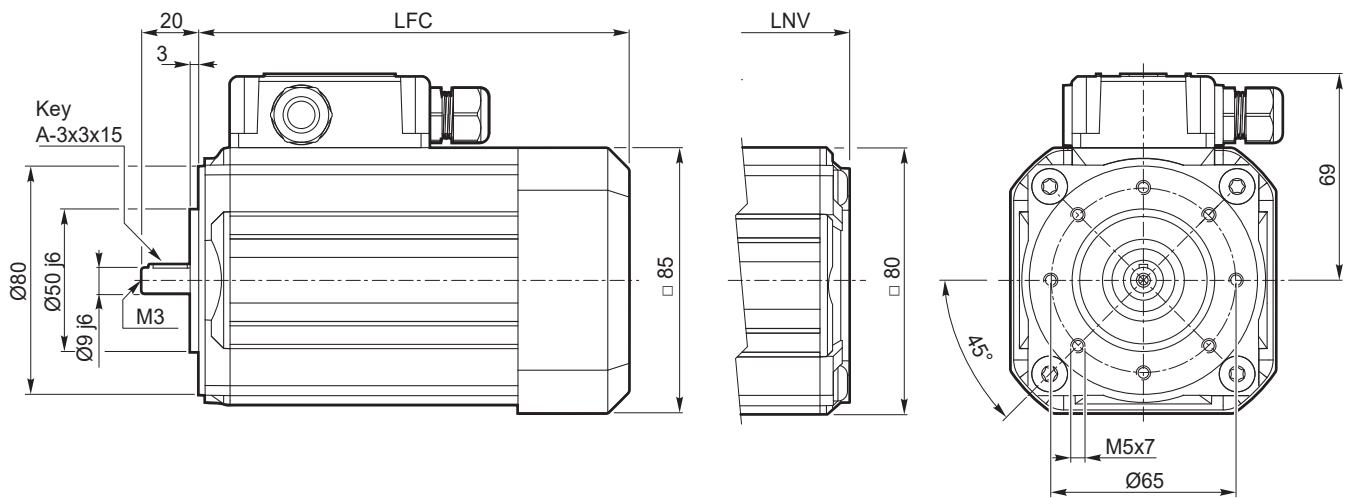

SMM	... TEFC		... TENV	
	LFC	kg	LNV	kg
5014	150.5	2.7	123.5	2.6
5024	175.5	3.5	148.5	3.4
5034	200.5	4.2	173.5	4.1

**Nota:**  
il condensatore sarà fornito a corredo

**Note:**  
the capacitor will be supplied

1 ~

SMM56.. - B14 - TEFC / TENV

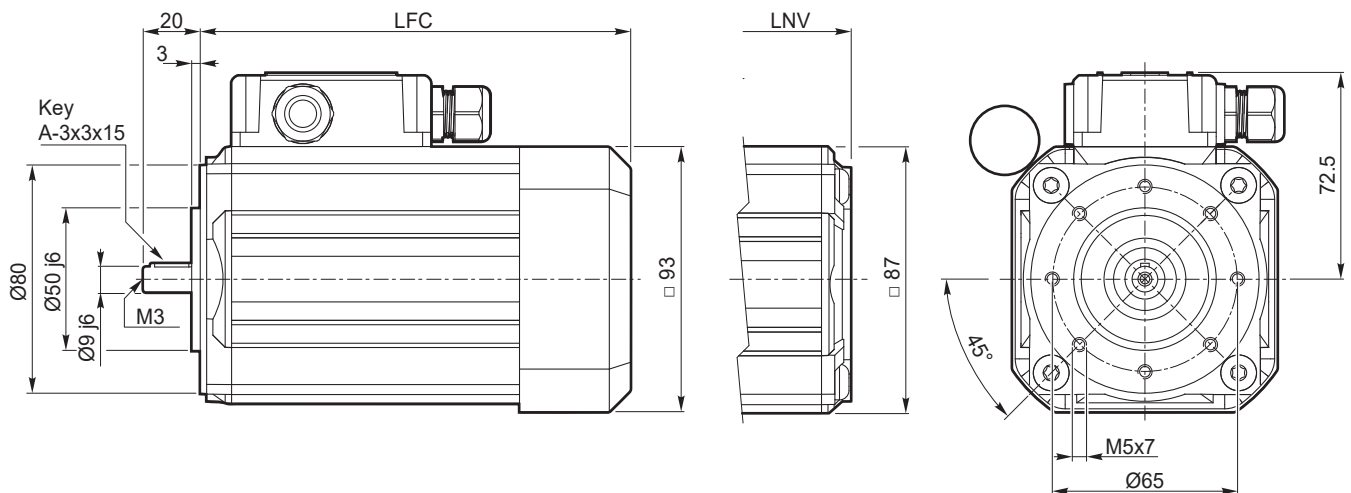

SMM	... TEFC		... TENV	
	LFC	kg	LNV	kg
5624	151	3.3	127	3.2
5634	171	3.9	147	3.8
5644	206	5.0	182	4.9

1~

SMM63.. - B14 - TEFC / TENV

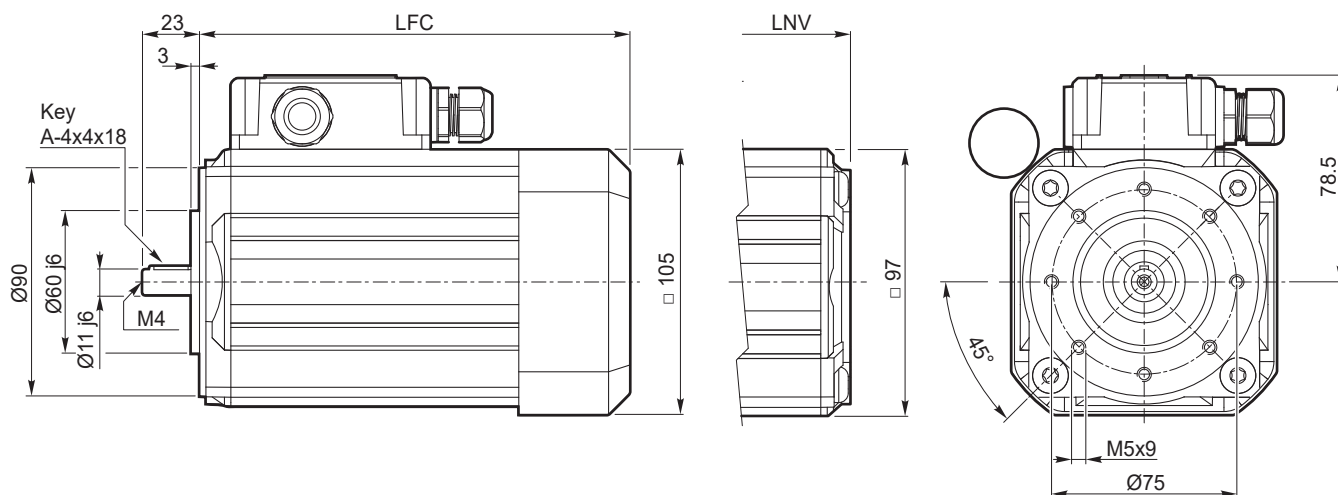

SMM	... TEFC		... TENV	
	LFC	Kg	LNV	Kg
6324	180.5	5.1	153.5	5.0
6334	205.5	6.2	178.5	6.1

1~

SMM71.. - B14 - TEFC / TENV

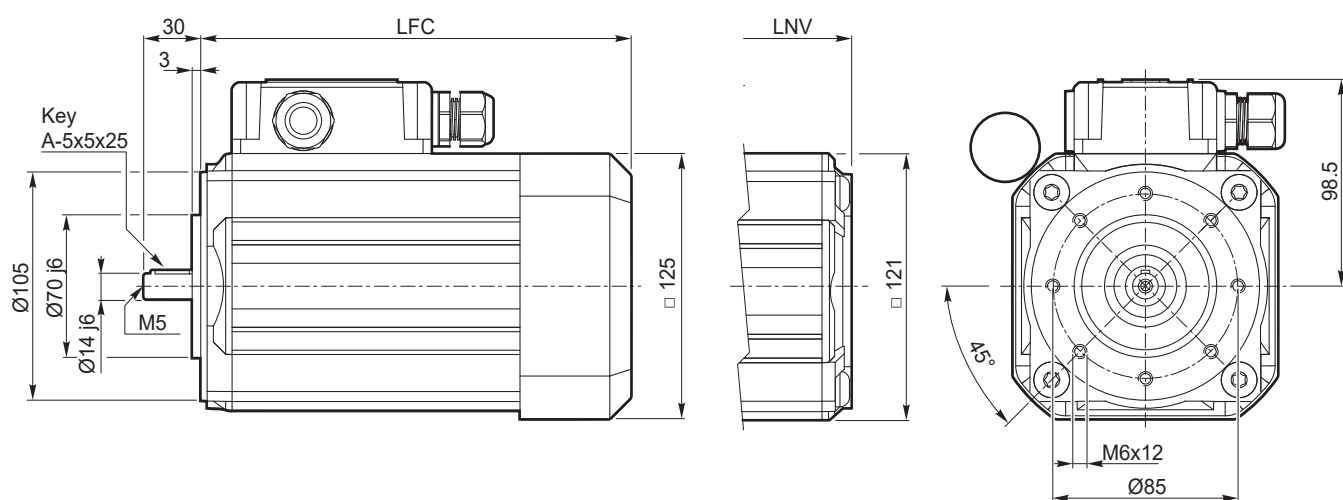

SMM	... TEFC		... TENV	
	LFC	Kg	LNV	Kg
7124	189	7.3	160.5	7.1
7134	214	9.2	185.5	9.0

Dimensioni motori monofase

Dimensions of single-phase motors

1 ~

SMM80.. - B14 - TEFC / TENV

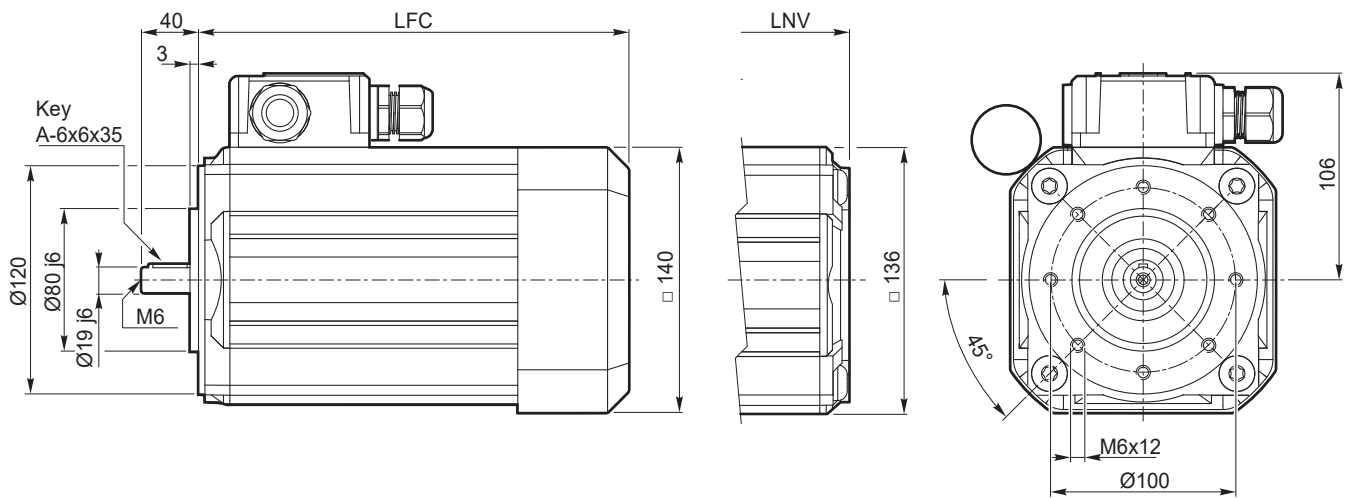

SMM	... TEFC		... TENV	
	LFC	kg	LNV	kg
8024	233	11.8	196	11.5

Cava esagonale

Hexagonal slot

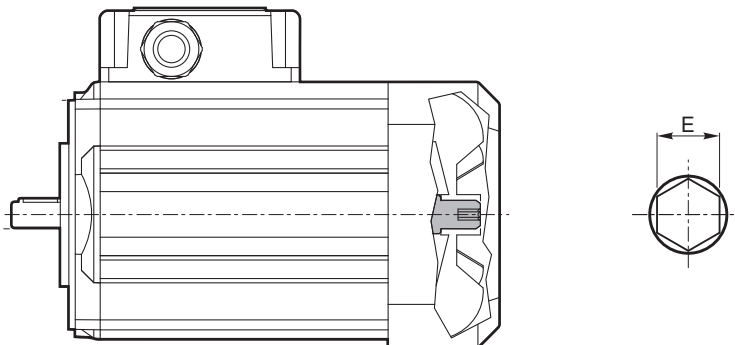

Esagono / Hexagon

SM..	E
50	4
56	
63	
71	6
80	
90	

Nota:

Installare a monte dell'alimentazione un dispositivo che assicuri la disconnessione della rete omipolare, durante le operazioni di rotazione manuale è obbligatorio l'utilizzo di tale sezionatore.

Il quadro elettrico del motore deve essere lucchettabile al fine di evitare il riarmo non previsto alla rete elettrica.

E' severamente vietata la messa in servizio del motore elettrico senza copriventola opportunamente montata.

Note:

Install a device upstream of the power supply that ensures the disconnection of the omnipolar mains; during manual turning operations, the use of such a disconnecter is mandatory.

The motor control panel must be padlockable in order to prevent unintended resetting to the mains.

It is strictly forbidden to start up the electric motor without a properly fitted fan cover.

**Motori elettrici CA - SMT BR**  
**autofrenanti**

Caratteristiche tecniche

**AC electric motors - SMT BR**  
**self-braking**

Technical features

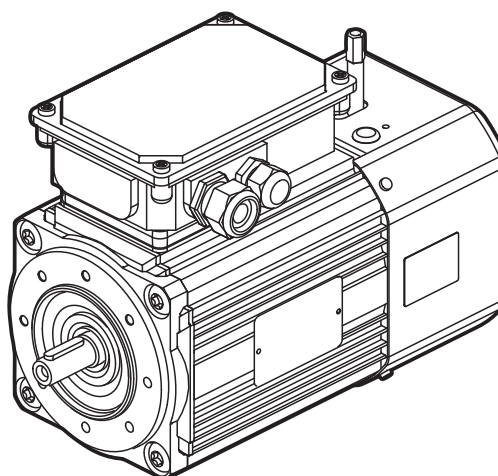
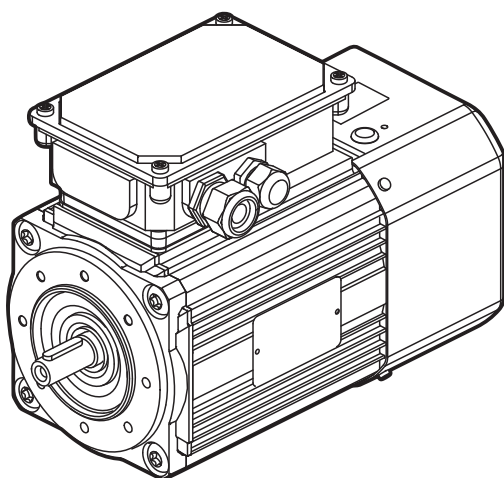

**SMT..TEFC BR**

**SMT..TEFC BR**

I motori autofrenanti delle serie SMT..BR hanno le seguenti caratteristiche principali:

- Costruzione compatta
- Motorizzazioni in corrente alternata trifase
- Carcasa estrusa in alluminio anodizzato nero
- Motore elettrico CA con grado di protezione IP66 (freno IP66 e IP65)
- Rumorosità e vibrazioni contenute
- Isolamento termico di classe F
- Flangia motore IEC B14
- Temperatura ambiente: 0°C / + 40°C (Per utilizzo a temperature diverse contattare il ns. servizio tecnico)
- Disponibili nella versione ventilata TEFC (servizio S1)
- Protezioni termiche PTO 150°C
- Adatti al funzionamento con alimentazione da inverter (Richiedere opzione freno con alimentazione separata)
- SMT80 e SMT90 conformi alla classe di rendimento IE3.
- Cava esagonale su albero motore lato NDE.
- La tolleranza di tensione è  $\pm 10\%$  per tutti i motori
- Il freno è a corrente continua

The self-braking motors of the SMT..BR series have the following main features:

- Compact construction
- Three-phase AC motors
- Extruded black anodised aluminium casing
- IP66-rated AC electric motor (IP66 and IP65 brake)
- Low noise and vibration
- Class F thermal insulation
- IEC B14 motor flange
- Ambient temperature: 0°C / + 40°C (For use at different temperatures please contact our technical service)
- Available in TEFC ventilated version (S1 service)
- PTO 150°C thermal protections
- Suitable for inverter-powered operation (Brake option with separate power supply required)
- SMT80 and SMT90 complying with efficiency class IE3.
- Hexagon socket on motor shaft NDE side.
- Voltage tolerance is  $\pm 10\%$  for all motors
- The brake is direct current

Motori elettrici CA - SMT BR  
autofrenanti

AC electric motors - SMT BR  
self-braking

Dati tecnici

Technical data

SMT..BR Motori trifase autofrenanti / Three-phase self-braking motors

(230-400 V / 50 Hz) poli / poles 4

Tipo Type	P <sub>n</sub> [kW]	M <sub>n</sub> [Nm]	n <sub>n</sub> [min <sup>-1</sup> ]	I <sub>n</sub> (400V) [A]	η %	cosφ	M <sub>s</sub> /M <sub>n</sub>	I <sub>s</sub> /I <sub>n</sub>	M <sub>k</sub> /M <sub>n</sub>	PTO	S TEFC	IP Motor Motor	M <sub>b</sub> [Nm]	IP Freno Brake
SMT6324B14.BR(L)	0.18	1.26	1360	0.69	57.0	0.66	2.50	2.90	2.50	PTO 150°	S3 75%	66	4	66
SMT6334B14.BR(L)	0.25	1.74	1375	0.94	62.0	0.64	2.80	3.00	2.80				4	66
SMT7124B14.BR(L)	0.37	2.52	1400	1.10	67.9	0.72	2.75	4.20	2.75				7.5	65
SMT7134B14.BR(L)	0.55	3.76	1395	1.55	70.2	0.73	2.90	4.40	2.90				7.5	65
SMT8024B14IE3.BR(L)	0.75	4.96	1440	1.94	82.5	0.68	3.6	6.00	3.70		S1		15	65
SMT8034B14IE3.BR(L)	1.1	7.25	1450	2.91	84.1	0.65	4.0	6.80	4.40				15	65
SMT9024B14IE3.BR(L)	1.5	10.0	1430	3.48	85.3	0.73	3.2	6.30	3.50				20	66
SMT9034B14IE3.BR(L)	2.2	14.9	1410	4.68	86.7	0.79	3.0	6.20	3.30				30	65

Per dimensioni e ulteriori dati consultare la documentazione disponibile sul sito [www.transtecno.com](http://www.transtecno.com)  
For dimensions and further data please refer to the documentation available at [www.transtecno.com](http://www.transtecno.com)

Dimensioni motori trifase

Dimensions of three-phase motors

3~

SMT63.. - B14 - TEFC - BR (L)

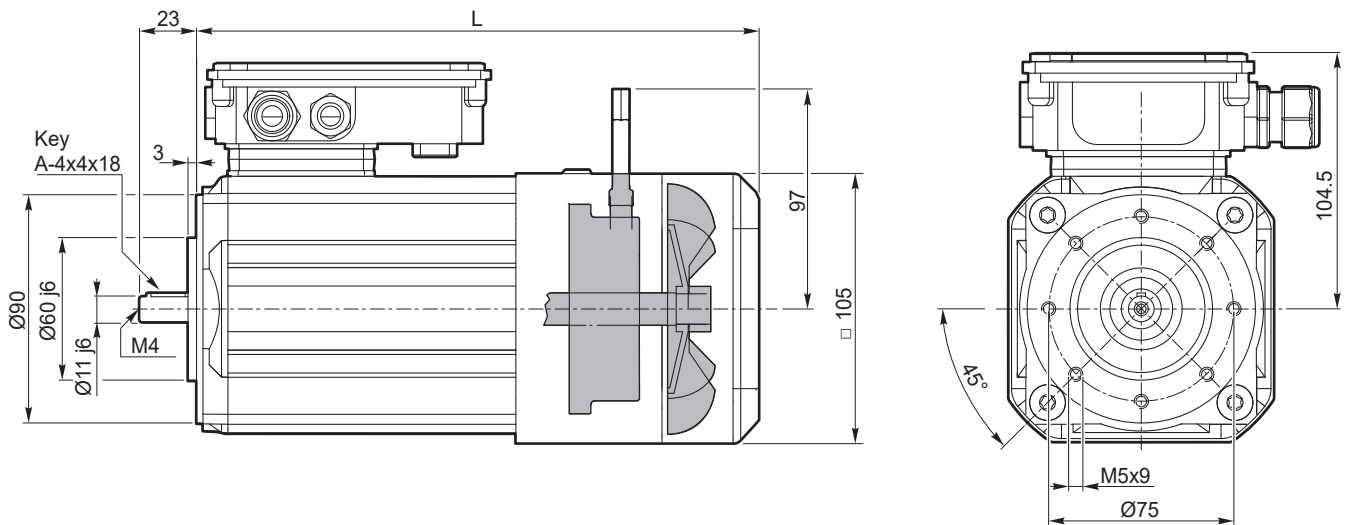

Nota:

La leva di sblocco è una opzione che va specificata in fase di ordine.

Note:

The release lever is an option that must be specified when ordering.

SMT..BR	... TEFC	
	L	Kg
6324	211	5.8
6334	226	6.5

3~

SMT71.. - B14 - TEFC - BR (L)

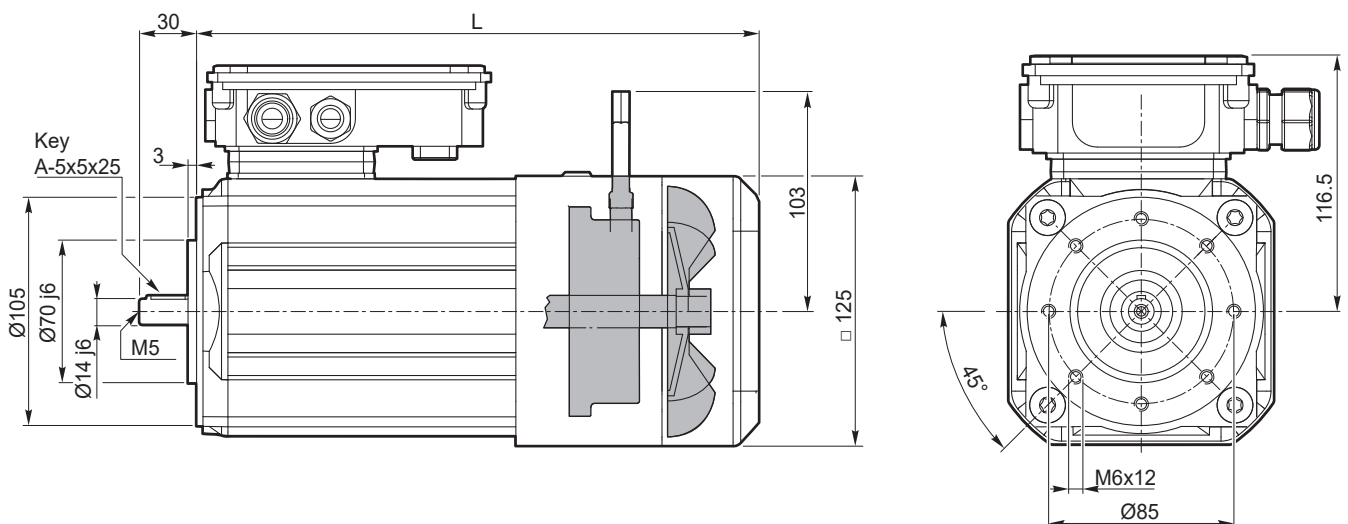

Nota:

La leva di sblocco è una opzione che va specificata in fase di ordine.

Note:

The release lever is an option that must be specified when ordering.

SMT..BR	... TEFC	
	L	Kg
7124	221	7.8
7134	236	8.9

Dimensioni motori trifase

Dimensions of three-phase motors

3~

SMT80.. - B14 - TEFC - BR (L)

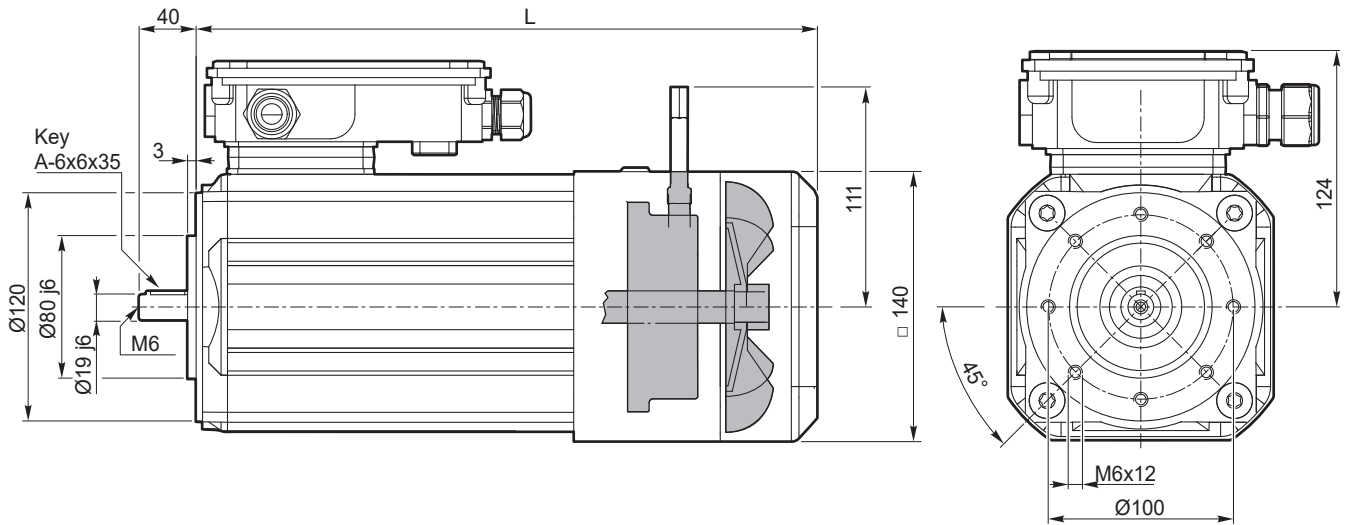

Nota:

La leva di sblocco è una opzione che va specificata in fase di ordine.

Note:

The release lever is an option that must be specified when ordering.

SMT..BR	... TEFC	
	L	Kg
8024	279.5	13.6
8034	329.5	17.9

3~

SMT90.. - B14 - TEFC - BR (L)

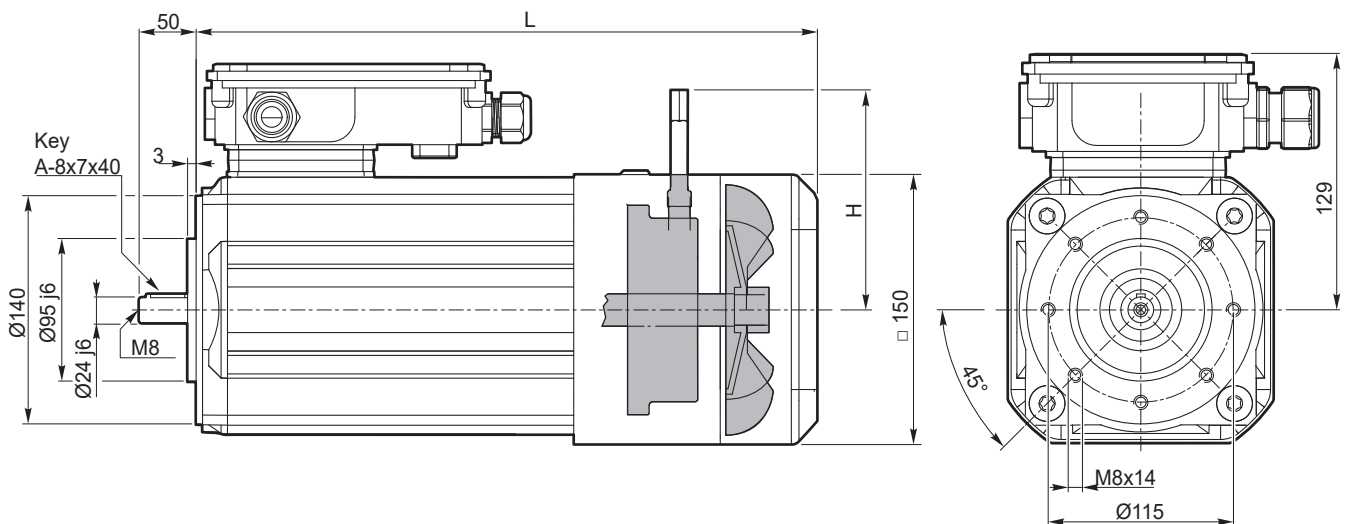

Nota:

La leva di sblocco è una opzione che va specificata in fase di ordine.

Note:

The release lever is an option that must be specified when ordering.

SMT..BR	... TEFC	
	L	Kg
9024	343	20.6
9034	373	24.7

SMT..BRL	... TEFC		
	L	H	Kg
9024	343	111.5	20.9
9034	367	138	25

**Motori elettrici CA - SMT SV**  
**servoventilati**

**Caratteristiche tecniche**

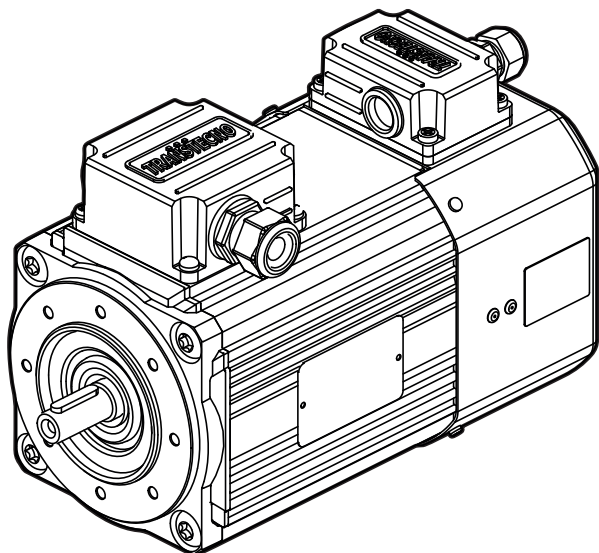

**SMT..SV**

I motori della serie SMT..SV hanno le seguenti caratteristiche principali:

- Costruzione compatta
- Motorizzazioni in corrente alternata trifase
- Carcasa estrusa in alluminio anodizzato nero
- Motore elettrico CA con grado di protezione IP 66 (solo motore - servoventola con grado di protezione IP44)
- Rumorosità e vibrazioni contenute
- Isolamento termico di classe F
- Flangia motore IEC B14
- Temperatura ambiente: 0°C / + 40°C (Per utilizzo a temperature diverse contattare il ns. servizio tecnico)
- Protezioni termiche PTO 150°C
- Adatti al funzionamento con alimentazione da inverter
- SMT80 e SMT90 conformi alla classe di rendimento IE3.
- La tolleranza di tensione è  $\pm 10\%$  per tutti i motori

**AC electric motors - SMT SV**  
**servo-ventilated**

**Technical features**



The SMT..SV series motors have the following main features:

- Compact construction
- Three-phase AC motors
- Extruded black anodised aluminium casing
- AC electric motor with IP 66 protection rating (motor only - servo fan with IP44 protection rating)
- Low noise and vibration
- Class F thermal insulation
- IEC B14 motor flange
- Ambient temperature: 0°C / + 40°C (For use at different temperatures please contact our technical service)
- PTO 150°C thermal protections
- Suitable for inverter-powered operation
- SMT80 and SMT90 complying with efficiency class IE3.
- Voltage tolerance is  $\pm 10\%$  for all motors

**Motori elettrici CA - SMT SV**  
servoventilati

**AC electric motors - SMT SV**  
servo-ventilated

Dati tecnici

Technical data

**SMT..SV** Motori trifase servoventilati / *Three-phase servo-ventilated motors*

(230-400 V / 50 Hz) poli / poles **4**

Tipo Type	P <sub>n</sub> [kW]	M <sub>n</sub> [Nm]	n <sub>n</sub> [min <sup>-1</sup> ]	I <sub>n</sub> (400V) [A]	η %	cosφ	M <sub>s</sub> /M <sub>n</sub>	I <sub>s</sub> /I <sub>n</sub>	M <sub>k</sub> /M <sub>n</sub>	PTO	S SV	IP Motore Motor	IP Servoventola Servo-fan	P <sub>sf</sub> [W]
SMT6324B14.SV	0.18	1.26	1360	0.69	57.0	0.66	2.50	2.90	2.50	PTO 150°	S3 75%	66	44	11-9
SMT6334B14.SV	0.25	1.74	1375	0.94	62.0	0.64	2.80	3.00	2.80				44	11-9
SMT6344B14.SV	0.37	2.60	1360	1.24	65.3	0.66	2.70	3.00	2.70				44	11-9
SMT7124B14.SV	0.37	2.52	1400	1.10	67.9	0.72	2.75	4.20	2.75				44	14-16
SMT7134B14.SV	0.55	3.76	1395	1.55	70.2	0.73	2.90	4.40	2.90				44	14-16
SMT7144B14.SV	0.75	5.09	1405	2.00	74.0	0.73	2.90	5.00	2.90				44	14-16
IE3	SMT8024B14IE3.SV	0.75	4.96	1440	1.94	82.5	3.6	6.00	3.70		S1	44	14-16	
	SMT8034B14IE3.SV	1.1	7.25	1450	2.91	84.1	4.0	6.80	4.40			44	14-16	
	SMT9024B14IE3.SV	1.5	10.0	1430	3.48	85.3	3.2	6.30	3.50			44	30-26	
	SMT9034B14IE3.SV	2.2	14.9	1410	4.68	86.7	0.79	3.0	6.20			3.30	44	30-26

Alimentazione della servoventola: 200-240 Vac / 50-60 Hz

Powering the servo-fan: 200-240 Vac / 50-60 Hz

Dimensioni motori trifase

Dimensions of three-phase motors

3 ~

SMT63.. - B14 - SV

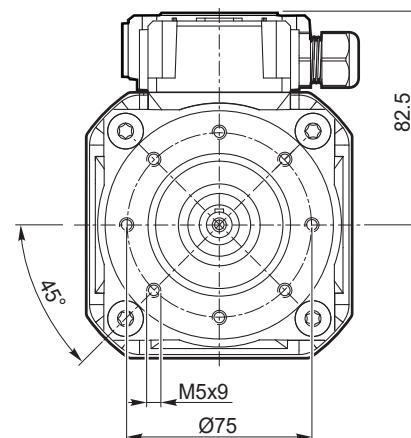
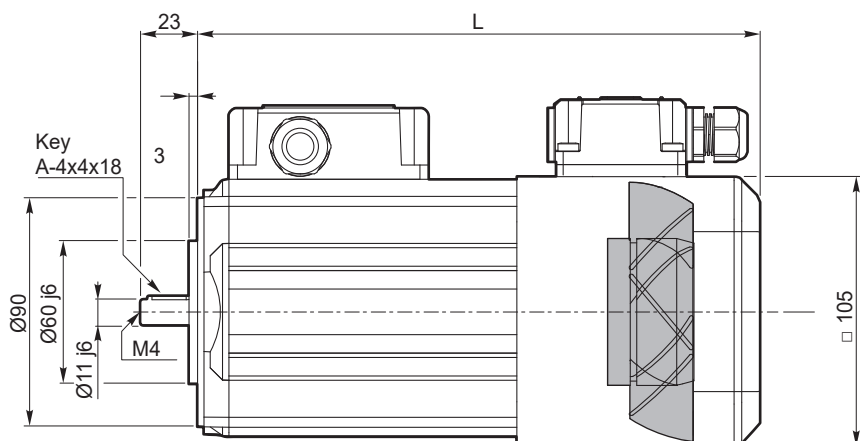

SMT	... SV	
	L	Kg
6324	210	5.0
6334	225	5.7
6344	250	6.8

3 ~

SMT71.. - B14 - SV

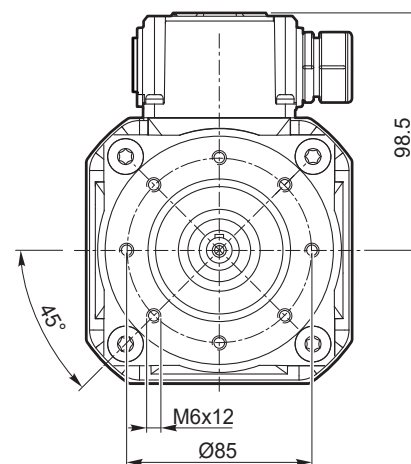
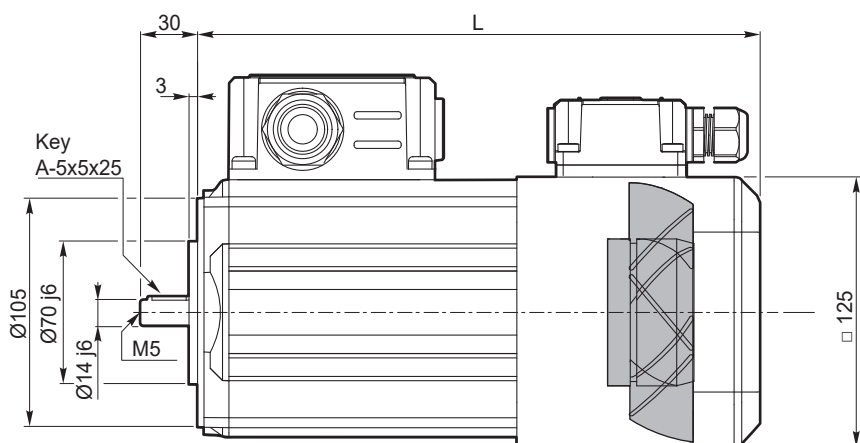

SMT	... SV	
	L	Kg
7124	219	7.5
7134	234	8.5
7144	259	10.2

Dimensioni motori trifase

Dimensions of three-phase motors

3~

SMT80.. - B14 - SV

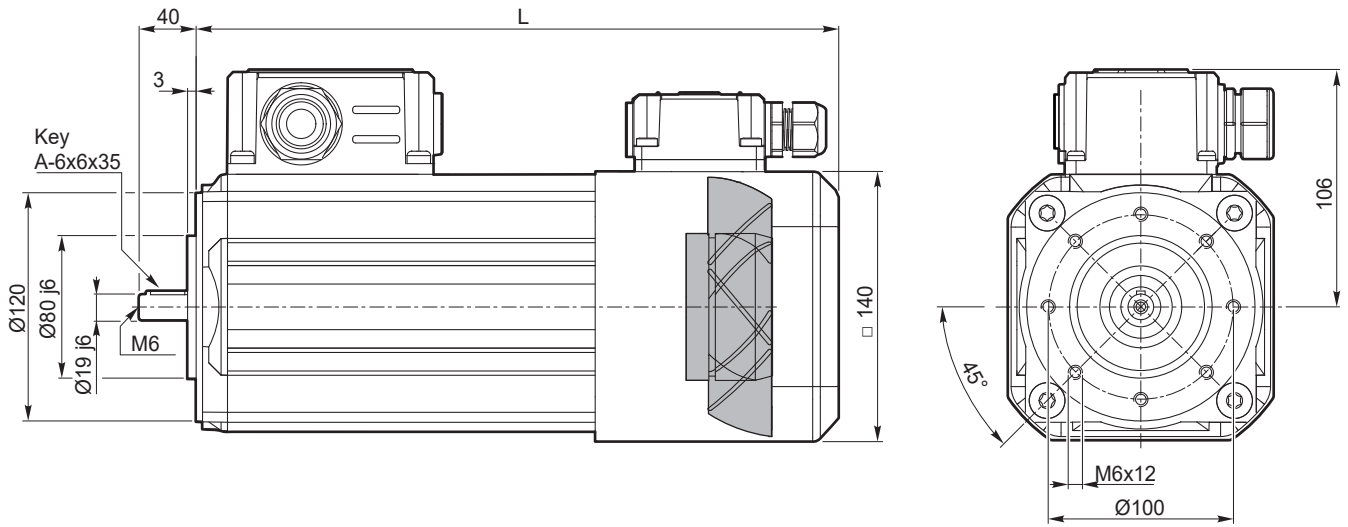

SMT	... SV	
	L	Kg
8024	278	12.7
8034	328	17

3~

SMT90.. - B14 - SV

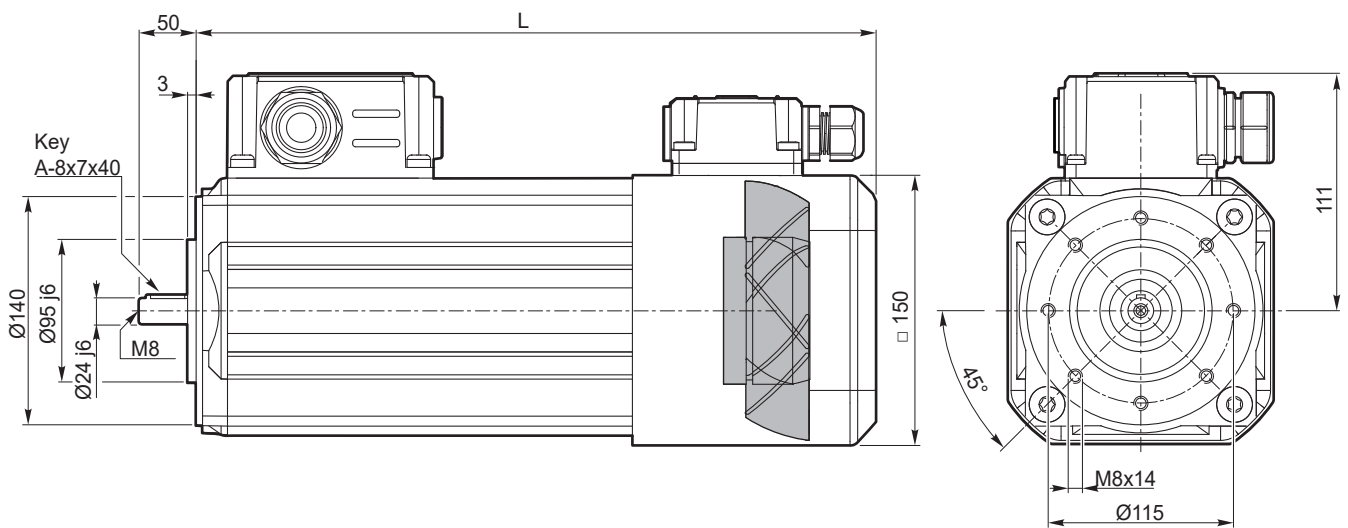

SMT	... SV	
	L	Kg
9024	341	19.3
9034	371	22.6

Caratteristiche tecniche

Technical features

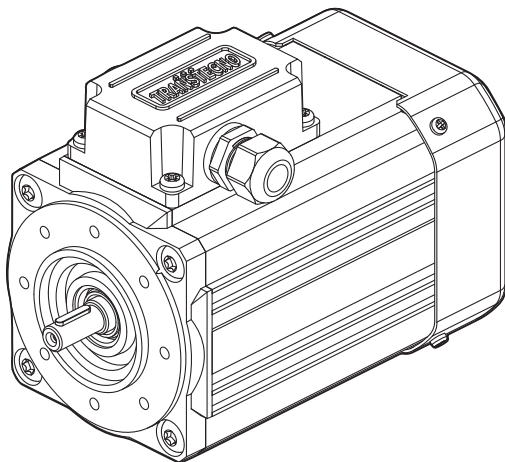

**SM .. UL/CSA**



File E511911

I motori certificati UL/CSA delle serie SMT ed SMM hanno le seguenti caratteristiche principali:

- Costruzione compatta
- Motorizzazioni in corrente alternata monofase e trifase
- Carcassa estrusa in alluminio anodizzato nero
- Motore elettrico CA con grado di protezione IP66 (escluso condensatore)
- Rumorosità e vibrazioni contenute
- Isolamento termico di classe F
- Flangia motore IECB14
- Temperatura ambiente: -20°C/+40°C
- Disponibili nella versione ventilata TEFC (servizio S1).
- Protezione termica PTO 150°C
- Motori trifase SMT dotati di separatori di fase
- Cava esagonale su albero motore lato NDE
- Condensatore di marcia per motori monofase SMM
- La tolleranza di tensione è  $\pm 10\%$
- Standard applicati:  
UL1004-1: Rotating Electrical Machines General Requirements  
CSA:100-14: Motors and Generators

The UL/CSA-certified motors of the SMT and SMM series have the following main features:

- Compact construction
- Single-phase and three-phase AC motors
- Extruded black anodised aluminium casing
- AC electric motor with IP66 protection rating (excluding capacitor)
- Low noise and vibration
- Class F thermal insulation
- IECB14 motor flange
- Ambient temperature: -20°C/+40°C
- Available in TEFC ventilated version (S1 service).
- Thermal protection PTO 150°C
- Three-phase SMT motors equipped with phase separators
- Hexagon socket on motor shaft NDE side
- Running capacitor for single-phase SMM motors
- Voltage tolerance is  $\pm 10\%$
- Standards applied:  
UL1004-1: Rotating Electrical Machines General Requirements  
CSA:100-14: Motors and Generators

Dati tecnici

Technical data

SMT Motori trifase / Three-phase motors

(230-400 V / 50 Hz) poli / poles 4

(460 V / 60 Hz) poli / poles 4

Tipo Type	P <sub>n</sub> [kW]	M <sub>n</sub> [Nm]	n <sub>n</sub> [min <sup>-1</sup> ]	V - f [V - Hz]	I <sub>n</sub> (400-460 V) [A]	η %	cosφ	M <sub>s</sub> /M <sub>n</sub>	I <sub>s</sub> /I <sub>n</sub>	M <sub>k</sub> /M <sub>n</sub>	PTO	S TEFC
5624	0.09	0.63	1365	400 - 50	0.45	47.3	0.61	2.50	2.40	2.70	PTO 150°	S1
	0.11		1660	460 - 60		50.3		2.60	2.60			
5634	0.12	0.88	1300	400 - 50	0.45	52.0	0.74	1.90	2.40	1.90		
	0.14	0.83	1600	460 - 60	0.42	59.0	0.71	2.10	2.70	2.10		
6324	0.18	1.26	1360	400 - 50	0.69	57.0	0.66	2.50	2.90	2.50		
	0.22	1.27	1650	460 - 60		59.7	0.67		3.00			
6334	0.25	1.74	1375	400 - 50	0.94	62.0	0.64	2.80	3.00	2.80		
	0.28	1.59	1690	460 - 60		61.3	0.61	3.00	3.20	3.00		
7124	0.37	2.52	1400	400 - 50	1.09	68.0	0.72	2.75	4.20	2.75		
	0.42	2.35	1700	460 - 60		68.1	0.71	2.90	4.50	2.90		
7134	0.55	3.76	1395	400 - 50	1.55	70.2	0.73	2.90	4.40	2.90		
	0.66	3.71	1700	460 - 60		73.2			4.80	2.80		
8024	0.75	4.96	1440	400 - 50	1.97	82.0	0.67	3.60	6.00	3.70		
	0.90	4.93	1740	460 - 60		84.3	0.68	3.40	6.40	3.60		
8034	1.10	7.25	1450	400 - 50	2.92	83.6	0.65	4.0	6.80	4.40		
	1.21	6.65	1740	460 - 60		77.6	0.67	4.4	7.00	4.50		
9024	1.50	10.0	1430	400 - 50	3.48	85.2	0.73	3.2	6.30	3.50		
	1.80	9.88	1740	460 - 60		85.4	0.76	3.4	6.50	3.40		

Mot

SMM Motori monofase / Single-phase motors

(115 V / 60 Hz) poli / poles 4

Tipo Type	P <sub>n</sub> [kW]	M <sub>n</sub> [Nm]	n <sub>n</sub> [min <sup>-1</sup> ]	V - f [V - Hz]	I <sub>n</sub> (115V) [A]	η %	cosφ	M <sub>s</sub> /M <sub>n</sub>	I <sub>s</sub> /I <sub>n</sub>	M <sub>k</sub> /M <sub>n</sub>	Cond./Cond. [μF]	PTO	S TEFC
5624	0.09	0.52	1665	115 - 60	1.60	50.0	0.98	0.64	1.95	1.51	20	PTO 150°	S1
6324	0.18	1.09	1570	115 - 60	2.70	58.5	0.99	1.0	2.1	1.50	40		
7124	0.37	2.18	1620	115 - 60	4.70	69.8	0.98	0.64	2.3	1.33	60		

Per la simbologia fare riferimento a pag. E3  
For symbols, please refer to page E3

Per dimensioni e ulteriori dati consultare la documentazione disponibile sul sito [www.transtecno.com](http://www.transtecno.com)  
For dimensions and further data please refer to the documentation available at [www.transtecno.com](http://www.transtecno.com)

3~

SMT56.. - B14 - TEFC

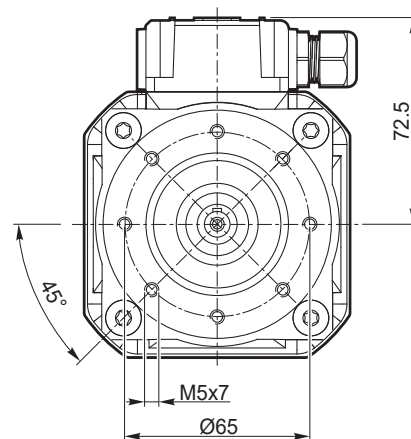
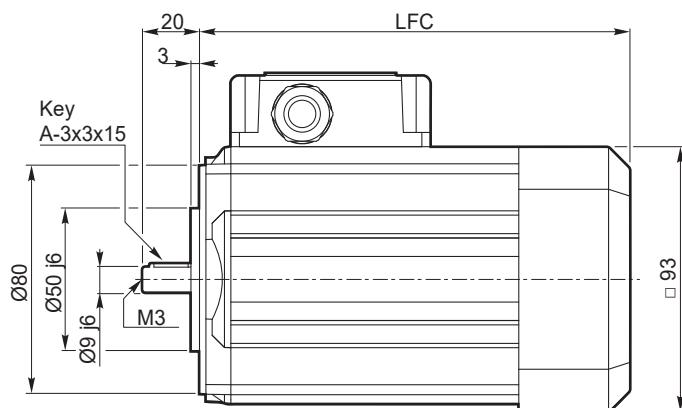

SMT	... TEFC	
	LFC	Kg
5624	186	3.1
5634	186	3.5

3~

SMT63.. - B14 - TEFC

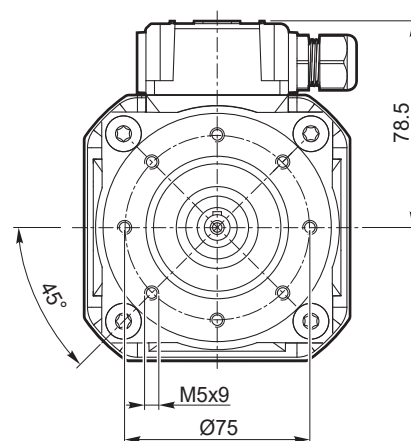
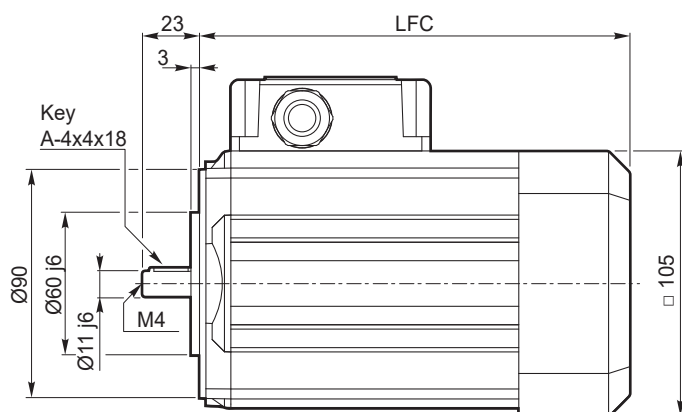

SMT	... TEFC	
	LFC	Kg
6324	205.5	4.7
6334	205.5	5.4

Dimensioni motori trifase

Dimensions of three-phase motors

3 ~

SMT71.. - B14 - TEFC

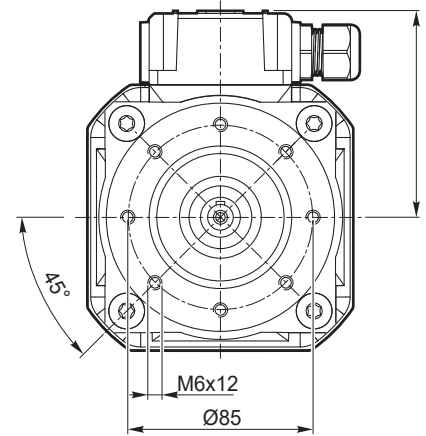
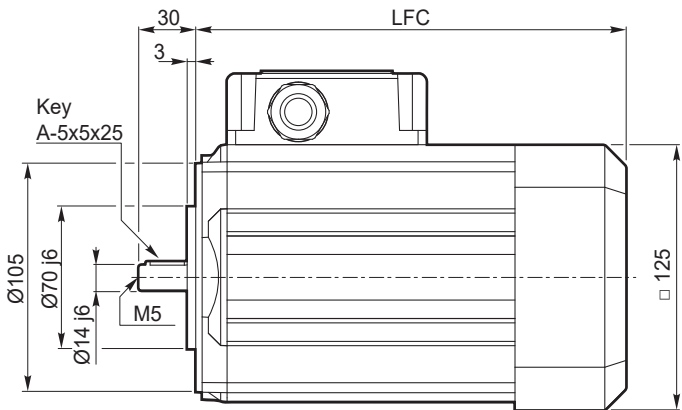

SMT	... TEFC	
	LFC	Kg
7124	214	7.0
7134	214	8.2

3 ~

SMT80.. - B14 - TEFC

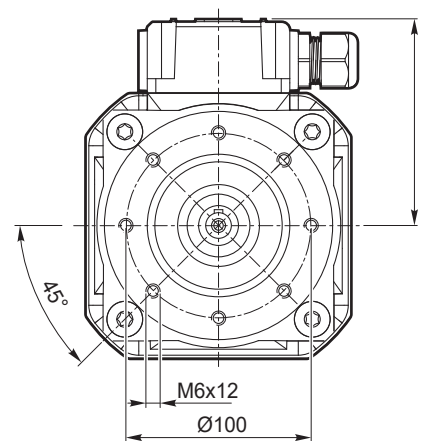
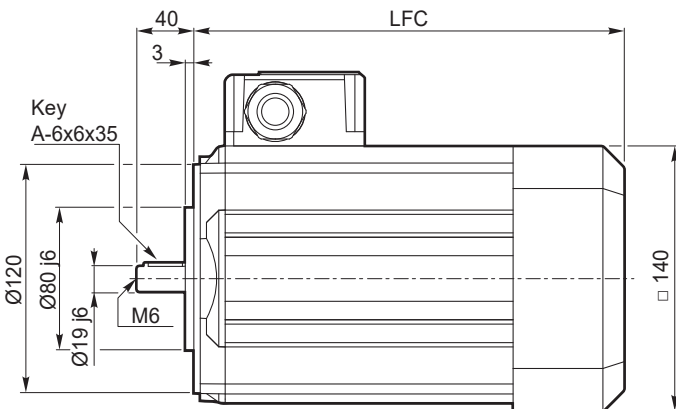

SMT	... TEFC	
	LFC	Kg
8024	283	12.8
8034	309	17.1

3 ~

SMT90.. - B14 - TEFC

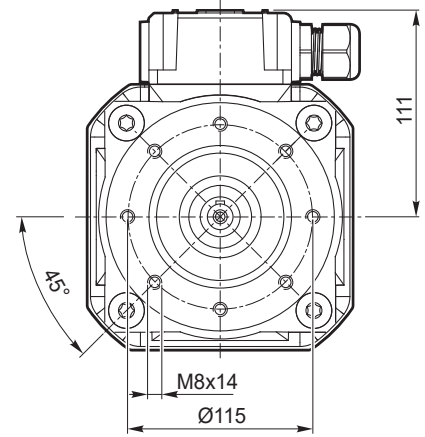
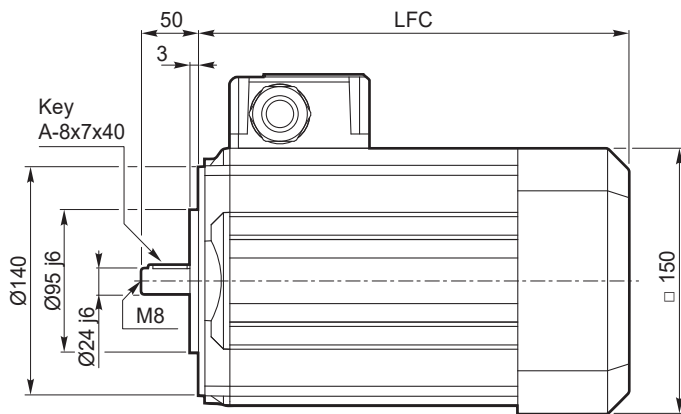

SMT	... TEFC	
	LFC	Kg
9024	313	18.5

Dimensioni motori monofase

Dimensions of single-phase motors

1 ~

SMM56.. - B14 - TEFC

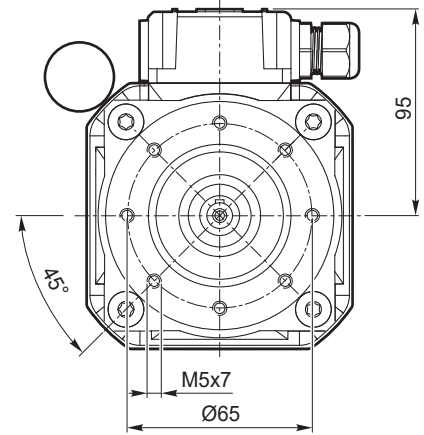
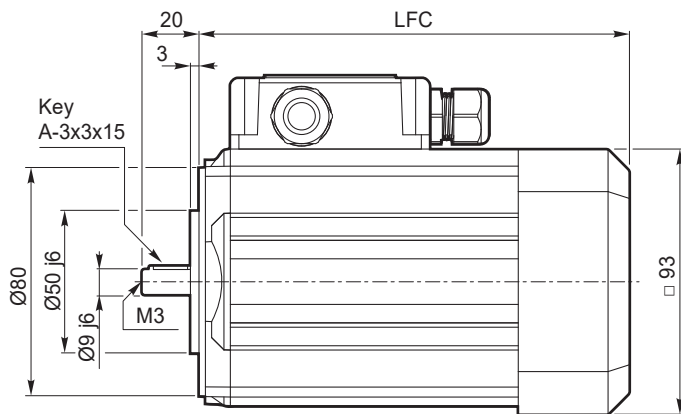

SMM	... TEFC	
	LFC	Kg
5624	186	3.6

1 ~

SMM63.. - B14 - TEFC

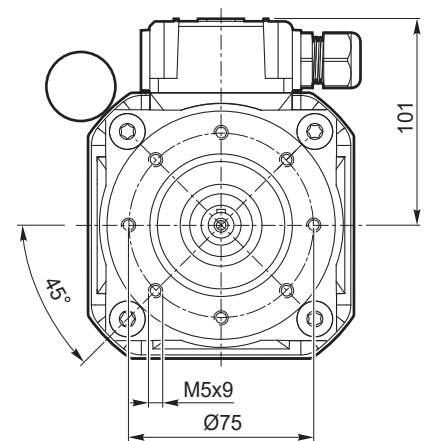
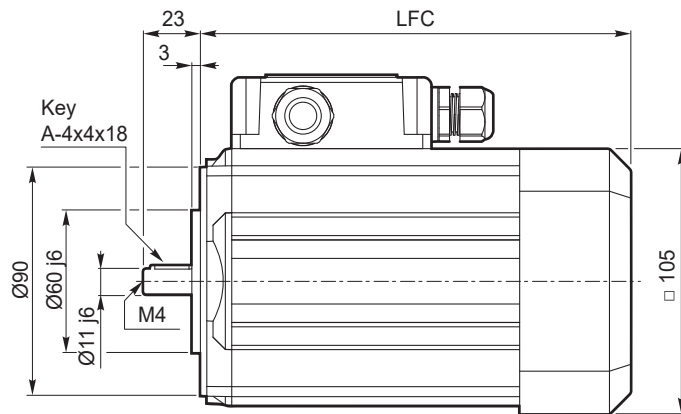

SMM	... TEFC	
	LFC	Kg
6324	205.5	5.5

1 ~

SMM71.. - B14 - TEFC

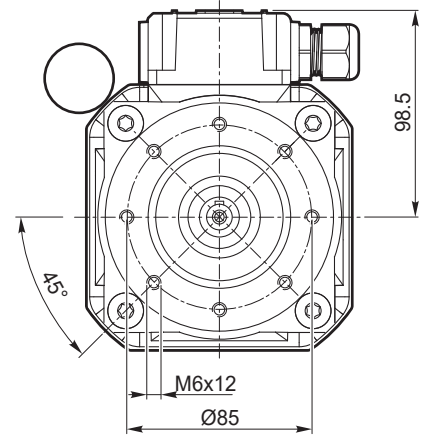
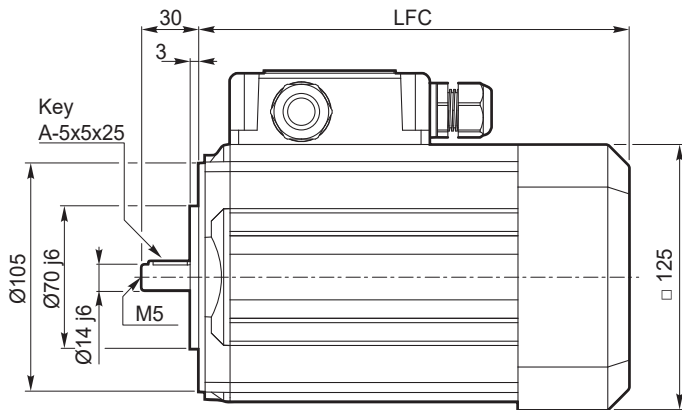

SMM	... TEFC	
	LFC	kg
7124	214	8.0



## DRAINTECH SRL HEADQUARTERS

Company subject to the management  
and coordination of INTERPUMP GROUP SPA  
Via 1° Maggio 3/5  
40011 Anzola dell'Emilia (BO) - ITALY  
T +39 051 72 74 47  
F + 39 051 03 53 028  
info@draintech.it  
[www.draintech.it](http://www.draintech.it)



member of  
**TRANSTECNO**  
group



**HANGZHOU INTERPUMP  
POWER TRANSMISSIONS CO LTD**  
No.4 Xiuyan Road Fengdu Industry Zone  
Pingyao Town Yuhang District  
Hangzhou City, Zhejiang Province  
311115 – CHINA  
T +86 571 86 92 02 60  
info-china@transtecno.cn  
[www.transtecno.cn](http://www.transtecno.cn)



**TRANSTECNO IBÉRICA  
THE MODULAR GEARMOTOR, S.A.**  
Carrer de la Ciència, 45  
08840 Viladecans (Barcelona) - SPAIN  
T +34 931 598 950  
info@transtecno.es  
[www.transtecno.es](http://www.transtecno.es)



**TRANSTECNO B.V.**  
Siliciumweg 32  
3812 SX Amersfoort - NETHERLANDS  
T +31(0) 33 45 19 505  
info@transtecno.nl  
[www.transtecno.nl](http://www.transtecno.nl)



**TRANSTECNO AANDRIJFTECHNIEK B.V.**  
Siliciumweg 32  
3812 SX Amersfoort - NETHERLANDS  
T +31 (0) 33 20 4 7 006  
info@transtecnoaandrijftechnik.nl  
[www.transtecnoaandrijftechnik.nl](http://www.transtecnoaandrijftechnik.nl)



**MA TRANSTECNO S.A.P.I. DE C.V.**  
Julián Sepúlveda Dávila #107,  
Parque Industrial SG  
Apodaca, Nuevo León, CP. 66640  
MÉXICO  
T +52 8113340920  
info@transtecno.com.mx  
[www.transtecno.com.mx](http://www.transtecno.com.mx)



**TRANSTECNO USA**  
8 Creek Parkway,  
Boothwyn PA 19061-8136 - UNITED STATES  
T + 1 (610) 4970154

**TRANSTECNO USA – WEST COAST BRANCH**  
14561 Fryelands Blvd SE  
Monroe, WA 98272 - UNITED STATES  
T +1 360-863-1300  
usaoffice@transtecno.com  
[www.transtecno.com](http://www.transtecno.com)



**TRANSTECNO CANADA**  
51 B Caldari Road Unit 10  
Vaughan, ON L4K 4G3 - CANADA  
T +1 905 761 0762  
canadaoffice@transtecno.com  
[www.transtecno.com](http://www.transtecno.com)



**TRANSTECNO INDIA**  
#6A, Sipcot Industrial complex, Phase-1,Elasagiri Road  
Hosur – 635126 Tamilnadu - INDIA  
T +91 4344 274434  
M +91 81443 88800

**TRANSTECNO INDIA – NORTH BRANCH**  
Plot No: 3 A, Sector 2, IIE, Sidcul, Pantnagar  
U.S. Nagar, Uttarakhand – 263153 - INDIA  
indiaoffice@transtecno.com  
[www.transtecno.com](http://www.transtecno.com)



**TRANSTECNO BRAZIL**  
Rua Gilberto de Zorzi, 525 Forqueta - CEP. 95115-730  
CX Postal 3544 Caxias do Sul RS – BRAZIL

**TRANSTECNO BRAZIL – SÃO PAULO BRANCH**  
R. Mafalda Barnabe Soliane, 314 – CEP. 13347-610  
Indaiatuba, São Paulo – BRAZIL  
T +55 19 3437 2520

**TRANSTECNO BRAZIL – PORTO ALEGRE BRANCH**  
Rua Dr. Freire Alemão 155 / 402 - CEP. 90450-060  
Auxiliadora Porto Alegre RS - BRAZIL  
T +55 51 4042 0916  
M +55 51 811 45 962  
braziloffice@transtecno.com  
[www.transtecno.com.br](http://www.transtecno.com.br)



**INTERPUMP ANTRIEBSTECHNIK GMBH**  
Büro Stuttgart - GERMANY  
T +49 (0)171 4781909  
germanoffice@transtecno.com  
[www.transtecno.com](http://www.transtecno.com)



**SALES OFFICE OCEANIA**  
Unit 5, 12 Nyholt Drive, Yatala 4207  
Queensland - AUSTRALIA  
T +61 07 3800 0103  
M +61 04 38060997



UNIT 9 , 94 Boundary Rd, Sunshine West 3020  
Victoria - AUSTRALIA  
T +61 9312 4722  
oceaniaoffice@transtecno.com  
[www.transtecno.com.au](http://www.transtecno.com.au)